

Dear JCB Customer

Even if you have operated this type of equipment before, it is very important that your new machines operations and functions are explained to you by a JCB Dealer Representative following delivery of your new machine.

Following the installation you will know how to gain maximum productivity and performance from your new product.

Please contact your local JCB dealer if the Installation Form has not yet been completed with you.

Your Local JCB Dealer is:

## **OPERATOR MANUAL**

**THIS MANUAL SHOULD ALWAYS STAY WITH THE MACHINE**

**8026 CTS, 8025 ZTS, 8030 ZTS, 8035 ZTS**

ENGLISH - 9811/9950 - ISSUE 1 - JANUARY 2011

Copyright © 2004 JCB SERVICE.

All rights reserved. No part of this publication may be reproduced, stored in a retrieval system, or transmitted in any form or by any other means, electronic, mechanical, photocopying or otherwise, without prior permission from JCB SERVICE.





---

**Contents****Page No.****Safety Notices**

Important Information .....	xv
The Operator Manual .....	xv
Safety Warnings .....	xvi

**Introduction**

About this Manual .....	1
Machine Model and Serial Number .....	1
Using this Manual .....	1
Left Side, Right Side .....	2
Cab/Canopy .....	3
Cross References .....	3
Machine Description .....	4
The JCB Mini Excavator .....	4
Intended Use .....	4
Component Location .....	4



---

<b>Contents</b>	<b>Page No.</b>
Safety Check List .....	6
Safety - Yours and Others .....	6
General Safety .....	7
Operating Safety .....	10
Maintenance Safety .....	19
Safety Labels .....	31
Introduction .....	31
Safety Label Identification .....	32
Identifying Your Machine .....	37
Machine Identification Plate .....	37
Component Identification Plates .....	39
Machine Security .....	42
Introduction .....	42
JCB Plantguard .....	42
Construction Equipment Security And Registration Scheme (CESAR) .....	42
<b>Operation</b>	
Introduction .....	45
Before Entering the Cab .....	46



<b>Contents</b>	<b>Page No.</b>
Entering and Leaving the Cab .....	48
Emergency Exit .....	49
Doors and Windows .....	51
Opening and Closing the Door .....	51
Securing the Door in the Open Position .....	52
Opening and Closing the Front Window .....	54
Removing and Refitting the Windscreen Lower Panel .....	55
Opening and Closing the Side Window .....	57
Seat Controls .....	58
Introduction .....	58
Standard Seat .....	59
Suspension Seat (If fitted) .....	60
Seat Belt .....	61
Static Seat Belt .....	61
Cab Layout .....	64
Component Key .....	65



<b>Contents</b>	<b>Page No.</b>
Drive Controls, Switches and Instruments .....	66
Drive Controls .....	66
Switches .....	70
Instrument Panel .....	75
Heater and Air Conditioning (If fitted) .....	79
Operating Levers/Pedals .....	80
Introduction .....	80
Control Layouts .....	80
Excavator Controls .....	82
Dozer Controls .....	90
Auxiliary Operation .....	92
Safety Equipment .....	94
Control Locks .....	94
Beacon .....	95
Overload Warning System (If fitted) .....	96
Fire Extinguisher (If fitted) .....	97
Before Starting the Engine .....	100
Starting the Engine .....	103
Warming Up .....	105
Immobiliser .....	106



<b>Contents</b>	<b>Page No.</b>
Stopping and Parking the Machine .....	111
Preparing the Machine for Travel .....	113
Introduction .....	113
Preparing for Site Travel .....	113
Working with the Machine .....	115
Operating Practices and Site Safety .....	115
Clothing and Safety Equipment .....	116
Danger Zone .....	116
Log Moving/Handling .....	117
Safety Practices .....	117
Working with the Excavator .....	119
Lifting (Object Handling) .....	125
Use of Machines on Gradients or Slopes .....	131
Working with the Dozer .....	133



<b>Contents</b>	<b>Page No.</b>
Operating Environment .....	135
Operating in Low Temperatures .....	135
Operating in a Cold Climate (Below 0°C) .....	136
Operating in High Temperatures .....	136
Operating in Dusty or Sandy Areas .....	137
Operating in Coastal Regions .....	137
Operating on Wet or Soft Ground .....	137
Getting the Machine Moving .....	138
Operating Practices .....	138
Operating Procedure .....	139
Refuelling the Machine .....	140
Low Fuel Levels .....	140
Filling the Tank .....	140
Moving A Disabled Machine .....	143
Introduction .....	143
Lowering the Boom in an Emergency .....	143
Retrieval .....	144





<b>Contents</b>	<b>Page No.</b>
Transporting the Machine .....	146
Preparing for Road Travel .....	146
Before Using the Trailer/Transporter .....	147
Loading a Machine onto the Transporting Vehicle .....	148
Securing the Machine .....	150
Unloading a Machine from the Transporting Vehicle .....	152
Lifting a Machine .....	154
Storage of the Machine .....	156
Introduction .....	156
Storage Area .....	156
Prepare the Machine for Storage .....	156
Put the Machine into Storage .....	157
During Storage .....	157
Take the Machine Out of Storage .....	158



<b>Contents</b>	<b>Page No.</b>
<b>Routine Maintenance</b>	
Service Requirements .....	159
Introduction .....	159
Owner/Operator Support .....	160
Service/Maintenance Agreements .....	161
Fit for Purpose Tests for Lifting Equipment .....	161
Obtaining Replacement Parts .....	161
Health and Safety .....	162
Lubricants .....	162
Battery .....	166
Service Schedules .....	170
Introduction .....	170
How to Use the Service Schedules .....	171
Calendar Equivalents .....	172
Pre Start Cold Checks, Service Points and Fluid Levels .....	173
Functional Test and Final Inspection .....	178
Fluids, Lubricants and Capacities .....	180
Coolant Mixtures .....	182
Fuels .....	184



<b>Contents</b>	<b>Page No.</b>
Tools .....	191
Toolbox (if fitted) .....	191
Carrying Tools onto the Machine .....	191
Prepare the Machine for Maintenance .....	192
Introduction .....	192
How to Make the Machine Safe (Excavator Lowered) .....	193
Cleaning the Machine .....	194
Introduction .....	194
Preparing the Machine for Cleaning .....	195
Cleaning the Machine .....	196
Cleaning the Tracks .....	197
Checking for Damage .....	199
Check the Machine Body and Structure .....	199
Check the Seat and Seat Belt .....	199
Check the Hydraulic Hoses and Fittings .....	200
Check the Electrical Circuits .....	201
Checking the ROPS/FOPS Structure .....	202
Checking the Ram Piston Rods .....	202



<b>Contents</b>	<b>Page No.</b>
Greasing .....	203
Introduction .....	203
Pivot Pins .....	204
Slew Ring Bearings .....	206
Slew Ring Gear Teeth .....	207
Access Panels .....	209
Introduction .....	209
Engine Cover .....	209
Hydraulic Bay Cover .....	211
Electrical System .....	212
Battery .....	212
Fuses .....	220
Engine .....	222
Oil and Filter .....	222
Cooling System .....	226
Fan Belt .....	229
Air Filter .....	230



<b>Contents</b>	<b>Page No.</b>
Fuel System .....	233
Introduction .....	233
Water Separator and Engine Fuel Filter .....	235
Bleeding the System .....	238
Hydraulic System .....	240
Introduction .....	240
Releasing the Hydraulic Pressure .....	242
Oil and Filter .....	243
Tracks and Running Gear .....	245
Tracks .....	245
Fire Extinguisher (if fitted) .....	250
Checking the Fire Extinguisher .....	250
<b>Optional Attachments</b>	
Introduction .....	251
Attachments For Your Machine .....	254
Impact Protection .....	255



<b>Contents</b>	<b>Page No.</b>
Connecting/Disconnecting Hydraulic Hoses .....	256
Introduction .....	256
Connecting the Hydraulic Hoses .....	257
Disconnecting the Hydraulic Hoses .....	259
Quick Release Couplings .....	261
Quickhitch Assembly .....	265
Introduction .....	265
Installation .....	266
Removal .....	267
Maintenance .....	267
Buckets .....	268
Bucket Selection .....	268
Removing a Bucket - Non Quickhitch Models .....	269
Installing a Bucket - Non Quickhitch Models .....	271
Removing a Bucket from a Quickhitch .....	272
Installing a Bucket on a Quickhitch .....	274
Replacing Bucket Teeth .....	276



<b>Contents</b>	<b>Page No.</b>
Quickhitch Rockbreaker .....	277
Introduction .....	277
Removing a Quickhitch Rockbreaker .....	277
Installing a Quickhitch Rockbreaker .....	281
Operation .....	282
<b>Specifications</b>	
Lifting Regulations and Safe Working Loads .....	285
Introduction .....	285
Static Dimensions .....	289
Performance Dimensions .....	292
Auxiliary Pressures .....	294
Noise Data .....	295
Introduction .....	295
All Machines .....	296
Vibration .....	297
Introduction .....	297
8026 CTS, 8025 ZTS, 8030 ZTS .....	299
8035 ZTS .....	300



<b>Contents</b>	<b>Page No.</b>
<b>Warranty Information</b>	
Machine Service Record Sheet .....	303
Registration Information .....	307
<b>European Community Standards</b>	
EC Declaration of Conformity .....	309
Introduction .....	309
Explanation of the EC Declaration of Conformity .....	312





---

# Safety Notices

## Important Information

T1-042

### The Operator Manual

#### **WARNING**

**You and others can be killed or seriously injured if you operate or maintain the machine without first studying the Operator Manual. You must understand and follow the instructions in the Operator Manual. If you do not understand anything, ask your employer or JCB dealer to explain it.**

INT-1-4-2

Do not operate the machine without an Operator Manual, or if there is anything on the machine you do not understand.

Treat the Operator Manual as part of the machine. Keep it clean and in good condition. Replace the Operator Manual immediately if it is lost, damaged or becomes unreadable.

### Safety Warnings



This safety alert system identifies important safety messages in this manual. When you see this symbol, be alert, your safety is involved, carefully read the message that follows, and inform other operators.

In this publication and on the machine, there are safety notices. Each notice starts with a signal word. The signal word meanings are given below.

#### **DANGER**

**Denotes an extreme hazard exists. If proper precautions are not taken, it is highly probable that the operator (or others) could be killed or seriously injured.**

INT-1-2-1

#### **WARNING**

**Denotes a hazard exists. If proper precautions are not taken, the operator (or others) could be killed or seriously injured.**

INT-1-2-2

#### **CAUTION**

**Denotes a reminder of safety practices. Failure to follow these safety practices could result in injury to the operator (or others) and possible damage to the machine.**

INT-1-2-3



---

# Introduction

## About this Manual

### Machine Model and Serial Number

This manual provides information for the following model(s) in the JCB machine range:

- 8026 CTS from serial number 1779000.
- 8025 ZTS from serial number 1226500.
- 8030 ZTS from serial number 1228500.
- 8035 ZTS from serial number 1230500.

### Using this Manual

This manual is arranged to give you a good understanding of the machine and its safe operation. It also contains maintenance information and specification data. Read this manual from front to back before using the machine for the

first time. Particular attention must be given to all the safety aspects of operating and maintaining the machine.

If there is anything you are not sure about, ask your JCB distributor or employer. Do not guess, you or others could be killed or seriously injured.

General warnings in this chapter are repeated throughout the book, as well as specific warnings. Read all the safety statements regularly, so you do not forget them. Remember that the best operators are the safest operators.

The illustrations in this manual are for guidance only. Where the machines differ, the text and or the illustration will specify.

This manual contains original instructions, verified by the manufacturer (or their authorised representative).

The manufacturer's policy is one of continuous improvement. The right to change the specification of the machine without notice is reserved. No responsibility will be accepted for discrepancies which may occur between specifications of the machine and the descriptions contained in this publication.

All optional equipment included in this manual may not be available in all territories.

### Left Side, Right Side

In this manual, 'left' **A** and 'right' **B** mean your left and right when you are seated correctly in the machine.

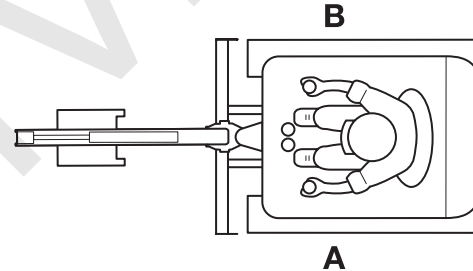

Fig 1.

731911-3



## Cab/Canopy

T1-003\_2

This manual frequently makes references to the cab. For instance, 'do not operate the machine without a manual in the cab'. It should be noted that these statements also apply to canopy build machines.

## Cross References

T1-004\_2

In this publication, page cross references are made by presenting the subject title printed in bold, italic and underlined. It is preceded by the 'go to' symbol. The number of the page upon which the subject begins, is indicated within the brackets. For example: **⇒ Cross References ( 3 )**.

## Machine Description

### The JCB Mini Excavator

P11-1001\_2

The JCB Mini machines are self-propelled tracked excavators with an upper structure capable of 360° rotation. They excavate, elevate, swing and discharge material by the action of a bucket fitted to the boom and dipper, without moving the undercarriage during any part of the working cycle of the machine.

### Intended Use

The machine is intended to be used under normal conditions for the applications described in this manual. If the machine is used for other purposes or in dangerous environments, for example in a flammable atmosphere or in areas with dust containing asbestos, special safety regulations must be followed and the machine must be equipped for use in these environments.

### Component Location

**Note:** *The illustration(s) show a typical machine model; your machine may look different from the model shown.*

- 1 Undercarriage
- 2 Main Frame
- 3 Cab
- 4 Dozer
- 5 Boom
- 6 Dipper
- 7 Bucket
- 8 Kingpost

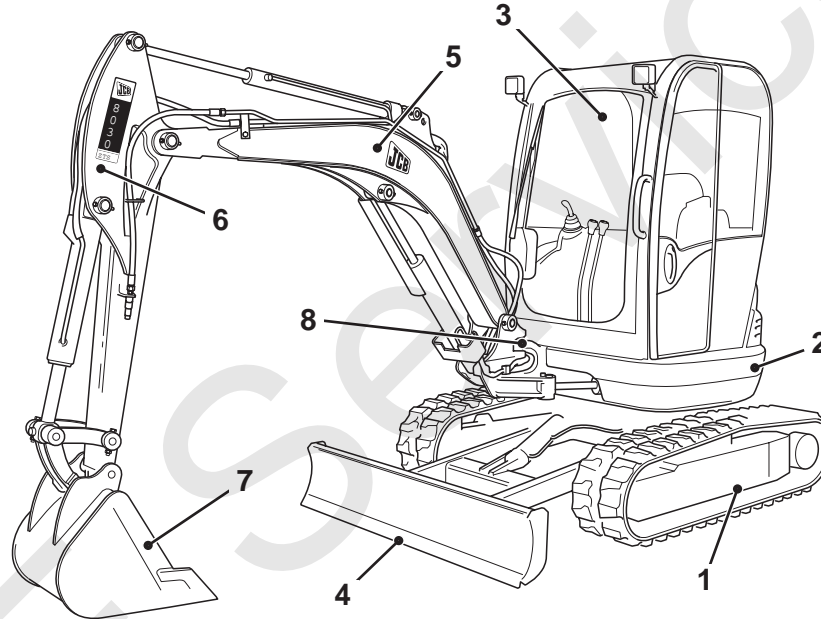

**Fig 2.**

C031400-B1

## Safety Check List

P11-1010\_3

### Safety - Yours and Others

INT-1-3-1\_3

All machinery can be hazardous. When a machine is correctly operated and properly maintained, it is a safe machine to work with. But when it is carelessly operated or poorly maintained it can become a danger to you (the operator) and others.

In this manual and on the machine you will find warning messages. Read and understand them. They tell you of potential hazards and how to avoid them. If you do not fully understand the warning messages, ask your employer or JCB distributor to explain them.

But safety is not just a matter of responding to the warnings. All the time you are working on or with the machine you must be thinking what hazards there might be and how to avoid them.

Do not work with the machine until you are sure that you can control it.

Do not start any job until you are sure that you and those around you will be safe.

If you are unsure of anything, about the machine or the job, ask someone who knows. Do not assume anything.

Remember

**BE CAREFUL**

**BE ALERT**

**BE SAFE**



### General Safety

---

#### **WARNING**

T1-043

To operate the machine safely you must know the machine and have the skill to use it. You must abide by all relevant laws, health and safety regulations that apply to the country you are operating in. The Operator Manual instructs you on the machine, its controls and its safe operation; it is not a training manual. If you are a new operator, get yourself trained in the skills of using a machine before trying to work with it. If you don't, you will not do your job well, and you will be a danger to yourself and others.

INT-1-4-1

---

#### **WARNING**

##### Care and Alertness

All the time you are working with or on the machine, take care and stay alert. Always be careful. Always be alert for hazards.

INT-1-3-5

---

#### **WARNING**

##### Clothing

You can be injured if you do not wear the proper clothing. Loose clothing can get caught in the machinery. Wear protective clothing to suit the job. Examples of protective clothing are: a hard hat, safety shoes, safety glasses, a well fitting overall, ear-protectors and industrial gloves. Keep cuffs fastened. Do not wear a necktie or scarf. Keep long hair restrained. Remove rings, watches and personal jewellery.

INT-1-3-6\_2

---

#### **WARNING**

##### Alcohol and Drugs

It is extremely dangerous to operate machinery when under the influence of alcohol or drugs. Do not consume alcoholic drinks or take drugs before or while operating the machine or attachments. Be aware of medicines which can cause drowsiness.

INT-1-3-9\_2



---

#### **WARNING**

##### Feeling Unwell

Do not attempt to operate the machine if you are feeling unwell. By doing so you could be a danger to yourself and those you work with.

8-1-2-4

---

#### **WARNING**

##### Mobile Phones

Switch off your mobile phone before entering an area with a potentially explosive atmosphere. Sparks in such an area could cause an explosion or fire resulting in death or serious injury.

Switch off and do not use your mobile phone when refuelling the machine.

INT-3-3-9

---

#### **WARNING**

##### Lifting Equipment

You can be injured if you use incorrect or faulty lifting equipment. You must identify the weight of the item to be lifted then choose lifting equipment that is strong enough and suitable for the job. Make sure that lifting equipment is in good condition and complies with all local regulations.

INT-1-3-7\_2

---

#### **WARNING**

##### Raised Equipment

Never walk or work under raised equipment unless it is supported by a mechanical device. Equipment which is supported only by a hydraulic device can drop and injure you if the hydraulic system fails or if the control is operated (even with the engine stopped).

Make sure that no-one goes near the machine while you install or remove the mechanical device.

13-2-3-7\_3



---

#### **WARNING**

##### **Raised Machine**

**NEVER** position yourself or any part of your body under a raised machine which is not properly supported. If the machine moves unexpectedly you could become trapped and suffer serious injury or be killed.

INT-3-3-7\_1

---

#### **DANGER**

##### **Lightning**

**Lightning can kill you. Do not use the machine if there is lightning in your area.**

5-1-1-2

---

#### **WARNING**

##### **Machine Modifications**

This machine is manufactured in compliance with legislative and other requirements. It should not be altered in any way which could affect or invalidate any of these requirements. For advice consult your JCB Distributor.

INT-1-3-10\_2



## Operating Safety

### WARNING

#### Machine Condition

A defective machine can injure you or others. Do not operate a machine which is defective or has missing parts. Make sure the maintenance procedures in this manual are completed before using the machine.

INT-2-1-2\_2

### WARNING

#### Machine Limits

Operating the machine beyond its design limits can damage the machine, it can also be dangerous. Do not operate the machine outside its limits. Do not try to upgrade the machine performance with unapproved modifications.

INT-2-1-4

### WARNING

#### Engine/Steering Failure

If the engine or steering fails, stop the machine as quickly as possible. Do not operate the machine until the fault has been corrected.

INT-2-1-5

### WARNING

#### Exhaust Gases

Breathing the machine exhaust gases can harm and possibly kill you. Do not operate the machine in closed spaces without making sure there is good ventilation. If possible, fit an exhaust extension. If you begin to feel drowsy, stop the machine at once and get into fresh air.

INT-2-1-10\_2



---

#### **WARNING**

##### Work Sites

Work sites can be hazardous. Inspect the site before working on it. You could be killed or injured if the ground gives way under your machine or if piled material collapses onto it. Check for potholes and hidden debris, logs, ironwork etc. Any of these could cause you to lose control of your machine. Check for utilities such as electric cables (overhead and underground), gas and water pipes etc. Mark the positions of the underground cables and pipes. Make sure that you have enough clearance beneath overhead cables and structures.

INT-2-2-1\_2

---

#### **WARNING**

##### Communications

Bad communications can cause accidents. Keep people around you informed of what you will be doing. If you will be working with other people, make sure any hand signals that may be used are understood by everybody. Work sites can be noisy, do not rely on spoken commands.

INT-2-2-3

---

#### **WARNING**

##### Parking

An incorrectly parked machine can move without an operator. Follow the instructions in the Operator Manual to park the machine correctly.

INT-2-2-4\_2



---

#### **WARNING**

##### **Banks and Trenches**

**Banked material and trenches can collapse. Do not work or drive too close to banks and trenches where there is danger of collapse.**

INT-2-2-5

---

#### **WARNING**

##### **Safety Barriers**

**Unguarded machines in public places can be dangerous. In public places, or where your visibility is reduced, place barriers around the work area to keep people away.**

INT-2-2-8

---

#### **DANGER**

##### **Sparks**

**Explosions and fire can be caused by sparks from the exhaust or the electrical system. Do not use the machine in closed areas where there is flammable material, vapour or dust.**

INT-2-2-10

---

#### **WARNING**

##### **Hazardous Atmospheres**

**This machine is designed for use in normal out door atmospheric conditions. It should not be used in an enclosed area without adequate ventilation. Do not use the machine in a potentially explosive atmosphere, i.e. combustible vapours, gas or dust, without first consulting your JCB Distributor.**

INT-2-1-14



---

#### CAUTION

##### Regulations

Obey all laws, work site and local regulations which affect you and your machine.

INT-1-3-3

---

#### WARNING

##### Practice

You or others can be killed or seriously injured if you do unfamiliar operations without first practising them. Practise away from the work site on a clear area. Keep other people away. Do not perform new operations until you are sure you can do them safely.

INT-2-1-1

---

#### WARNING

Airborne particles of light combustible material such as straw, grass, wood shavings, etc. must not be allowed to accumulate within the engine compartment or in the propshaft guards (when fitted). Inspect these areas frequently and clean at the beginning of each work shift or more often if required. Before opening the engine cover, ensure that the top is clear of debris.

5-3-1-12\_3

---

#### WARNING

Keep the machine controls clean and dry. Your hands and feet could slide off slippery controls. If that happens you could lose control of the machine.

2-2-3-6

#### **WARNING**

##### **Electrical Power Cables**

You could be electrocuted or badly burned if you get the machine or its attachments too close to electrical power cables.

You are strongly advised to make sure that the safety arrangements on site comply with the local laws and regulations concerning work near electric power lines.

Before you start using the machine, check with your electricity supplier if there are any buried power cables on the site.

There is a minimum clearance required for working beneath overhead power cables. You must obtain details from your local electricity supplier.

2-2-5-4

#### **CAUTION**

If you have an attachment which is not covered in the Operator Manual do not install it, use it or remove it until you have obtained, read and understood the pertinent information. Install attachments only on the machines for which they were designed.

5-5-1-1\_2

#### **WARNING**

Use only the JCB approved attachments that are specified for your machine. Operating with non-specified attachments can overload the machine, causing possible damage and machine instability which could result in injury to yourself or others.

The use of non-approved attachments could invalidate your warranty.

2-4-5-2\_1





---

#### DANGER

---

##### Working Platform

Using the machine as a working platform is hazardous; you can fall off and be killed or injured. Never use the machine as a working platform.

5-1-5-9

---

#### WARNING

---

##### Machine Safety

Stop work at once if a fault develops. Abnormal sounds and smells can be signs of trouble. Inspect and repair before resuming work.

8-1-2-3

---

#### WARNING

Touching hot surfaces can burn skin. The engine and machine components will be hot after the unit has been running. Allow the engine and components to cool before servicing the unit.

10-1-1-40

---

#### WARNING

---

##### Travelling at High Speeds

Travelling at high speeds can cause accidents. Do not reverse in a high gear with full throttle. Always travel at a safe speed to suit working conditions.

INT-5-3-3

---

#### WARNING

The engine has exposed rotating parts. Switch OFF the engine before working in the engine compartment. Do not use the machine with the engine cover open.

5-2-6-5

#### **WARNING**

You could be killed or seriously injured if you operate a machine with a damaged or missing ROPS/FOPS. If the Roll Over Protection Structure (ROPS)/Falling Objects Protection Structure (FOPS) has been in an accident, do not use the machine until the structure has been renewed. Modifications and repairs that are not approved by the manufacturer may be dangerous and will invalidate the ROPS/FOPS certification.

INT-2-1-9\_6

#### **WARNING**

Machines with a TOPS structure are equipped with a seat belt. The TOPS structure is designed to give you protection in an accident. If you do not wear the seat belt you could be thrown off the machine and crushed. You must wear a seat belt when using the machine. Fasten the seat belt before starting the engine.

2-2-1-9

#### **WARNING**

##### Hillsides

Operating the machine on hillsides can be dangerous if proper precautions are not taken. Ground conditions can be changed by rain, snow, ice etc. Check the site carefully. When applicable, keep all attachments low to the ground.

8-1-1-1

#### **WARNING**

##### Visibility

Accidents can be caused by working in poor visibility. Use your lights to improve visibility. Keep the road lights, windows and mirrors clean.

Do not operate the machine if you cannot see clearly.

5-1-4-7

---

#### WARNING

##### **Keep Your Hands and Feet Inside the Vehicle**

When using the machine, keep your hands and feet clear of moving parts. Keep your hands and feet within the operator compartment while the vehicle is in motion.

13-1-1-17

---

#### WARNING

##### **Controls**

You or others can be killed or seriously injured if you operate the control levers from outside the machine. Operate the control levers only when you are correctly seated.

0179\_2

---

#### CAUTION

##### **Passengers**

Passengers in or on the machine can cause accidents. Do not carry passengers.

INT-2-2-2\_1

---

#### WARNING

##### **Fires**

If your machine is equipped with a fire extinguisher, make sure it is checked regularly. Keep it in the correct machine location until you need to use it.

Do not use water to put out a machine fire, you could spread an oil fire or get a shock from an electrical fire. Use carbon dioxide, dry chemical or foam extinguishers. Contact your nearest fire department as quickly as possible. Firefighters should use self-contained breathing apparatus.

INT-3-2-7\_2



---

#### WARNING

Should the machine start to roll over, you can be crushed if you try to leave the cab. If the machine starts to roll over, do not try and jump from the cab. Stay in the cab, with your seat belt fastened.

INT-2-1-12

---

#### WARNING

##### Seat Belt

Operating the machine without a seat belt can be dangerous. Before starting the engine, make sure your seat belt is fastened. Check the tightness and condition of the seat belt securing bolts regularly (see maintenance schedules).

INT-2-1-8\_1

---

#### WARNING

##### Safe Working Loads

Overloading the machine can damage it and make it unstable. Study the specifications in the Operator Manual before using the machine.

7-1-1-8\_2

---

#### WARNING

##### Machine Safety

Stop work at once if a fault develops. Abnormal sounds and smells can be signs of trouble. Inspect and repair before resuming work.

8-1-2-3

### WARNING

Machines with a TOPS structure are equipped with a seat belt. The TOPS structure is designed to give you protection in an accident. If you do not wear the seat belt you could be thrown off the machine and crushed. You must wear a seat belt when using the machine. Fasten the seat belt before starting the engine.

2-2-1-9

## Maintenance Safety

### WARNING

#### Communications

Bad communications can cause accidents. If two or more people are working on the machine, make sure each is aware of what the others are doing. Before starting the engine make sure the others are clear of the danger areas; examples of danger areas are: the rotating blades and belt on the engine, the attachments and linkages, and anywhere beneath or behind the machine. People can be killed or injured if these precautions are not taken.

INT-3-1-5

---

#### **WARNING**

##### Repairs

If your machine does not function correctly in any way, get it repaired straight away. Neglect of necessary repairs could result in an accident or affect your health. Do not try to do repairs or any other type of maintenance work you do not understand. To avoid injury and/or damage get the work done by a specialist engineer.

GEN-1-5\_2

---

#### **WARNING**

##### Metal Splinters

You can be injured by flying metal splinters when driving metal pins in or out. Use a soft faced hammer or copper pin to remove and fit metal pins. Always wear safety glasses.

INT-3-1-3\_2

---

#### **WARNING**

##### Electrical Circuits

Understand the electrical circuit before connecting or disconnecting an electrical component. A wrong connection can cause injury and/or damage.

INT-3-1-4

---

#### **WARNING**

##### Fluid Under Pressure

Fine jets of fluid at high pressure can penetrate the skin. Keep face and hands well clear of fluid under pressure and wear protective glasses and gloves. Hold a piece of cardboard close to suspected leaks and then inspect the cardboard for signs of fluid. If fluid penetrates your skin, get medical help immediately.

INT-3-1-10\_3

#### WARNING

##### Hydraulic Pressure

Hydraulic fluid at system pressure can injure you. Before connecting or removing any hydraulic hose, residual hydraulic pressure trapped in the service hose line must be vented. Make sure the hose service line has been vented before connecting or removing hoses. Make sure the engine cannot be started while the hoses are open.

INT-3-1-11\_2

#### WARNING

##### Fuel

Fuel is flammable; keep naked flames away from the fuel system. Stop the engine immediately if a fuel leak is suspected. Do not smoke while refuelling or working on the fuel system. Do not refuel with the engine running. Completely wipe off any spilt fuel which could cause a fire. There could be a fire and injury if you do not follow these precautions.

INT-3-2-2\_3

#### WARNING

##### Oil

Oil is toxic. If you swallow any oil, do not induce vomiting, seek medical advice. Used engine oil contains harmful contaminants which can cause skin cancer. Do not handle used engine oil more than necessary. Always use barrier cream or wear gloves to prevent skin contact. Wash skin contaminated with oil thoroughly in warm soapy water. Do not use petrol, diesel fuel or paraffin to clean your skin.

INT-3-2-3

#### CAUTION

It is illegal to pollute drains, sewers or the ground. Clean up all spilt fluids and/or lubricants.

Used fluids and/or lubricants, filters and contaminated materials must be disposed of in accordance with local regulations. Use authorised waste disposal sites.

INT-3-2-14



---

#### **WARNING**

##### **Soft Ground**

A machine can sink into soft ground. Never work under a machine on soft ground.

INT-3-2-4

---

#### **WARNING**

Always wear safety glasses when dismantling assemblies containing components under pressure from springs. This will protect against eye injury from components accidentally flying out.

GEN-6-2

---

#### **CAUTION**

##### **Rams**

The efficiency of the rams will be affected if they are not kept free of solidified dirt. Clean dirt from around the rams regularly. When leaving or parking the machine, close all rams if possible to reduce the risk of weather corrosion.

INT-3-2-10

---

#### **CAUTION**

##### **Cleaning**

Cleaning metal parts with incorrect solvents can cause corrosion. Use only recommended cleaning agents and solvents.

INT-3-2-11



---

#### WARNING

When using cleaning agents, solvents or other chemicals, you must adhere to the manufacturer's instructions and safety precautions.

GEN-1-9

---

#### CAUTION

##### 'O' rings, Seals and Gaskets

Badly fitted, damaged or rotted 'O' rings, seals and gaskets can cause leakages and possible accidents. Renew whenever disturbed unless otherwise instructed. Do not use Trichloroethane or paint thinners near 'O' rings and seals.

INT-3-2-12

---

#### WARNING

##### Hydraulic Hoses

Damaged hoses can cause fatal accidents. Inspect the hoses regularly. Do not use the machine if a hose or hose fitting is damaged.

INT-3-3-2\_4

---

#### CAUTION

Waxoyl contains turpentine substitute which is flammable. Keep flames away when applying Waxoyl. Waxoyl can take a few weeks to dry completely. Keep flames away during the drying period.

Do not weld near the affected area during the drying period. Take the same precautions as for oil to keep Waxoyl off your skin. Do not breathe the fumes. Apply in a well-ventilated area.

5-3-1-9



#### **WARNING**

##### **Working Under the Machine**

**Make the machine safe before getting beneath it. Ensure that any fitments on the machine are secure; engage the park brake, remove the starter key, disconnect the battery.**

INT-3-3-8\_2

### WARNING

Certain seals and gaskets (e.g. crankshaft oil seal) on JCB machines contain fluoroelastomeric materials such as Viton, Fluorel and Technoflon. Fluoroelastomeric materials subjected to high temperatures can produce highly corrosive hydrofluoric acid. **THIS ACID CAN SEVERELY BURN.**

New fluoroelastomeric components at ambient temperature require no special safety precautions.

Used fluoroelastomeric components whose temperatures have not exceeded 300°C (572°F) require no special safety precautions. If evidence of decomposition (e.g. charring) is found, refer to the next paragraph for safety instructions **DO NOT TOUCH COMPONENT OR SURROUNDING AREA.**

Used fluoroelastomeric components subjected to temperatures greater than 300°C (572°F) (e.g. engine fire) must be treated using the following safety procedure. Make sure that heavy duty gloves and

special safety glasses are worn:

- 1 Thoroughly wash contaminated area with 10% calcium hydroxide or other suitable alkali solution, if necessary use wire wool to remove burnt remains.
- 2 Thoroughly wash contaminated area with detergent and water.
- 3 Contain all removed material, gloves etc. used in this operation in sealed plastic bags and dispose of in accordance with Local Authority Regulations.

**DO NOT BURN FLUOROELASTOMERIC MATERIALS.**

INT-3-3-5\_3



---

#### WARNING

Protect your eyes when grinding metal. Wear safety glasses or goggles. Remove or protect any combustible materials from the area which could be ignited by sparks.

GEN-1-12

---

#### WARNING

To avoid burning, wear protective gloves when handling hot components. To protect your eyes, wear goggles when using a brush to clean components.

HYD-1-3\_2

### WARNING

#### Arc Welding

To prevent the possibility of damage to electronic components, disconnect the battery and the alternator before arc-welding on the machine or attached implements.

If the machine is equipped with sensitive electrical equipment, i.e. amplifier drivers, electronic control units (E.C.U.s), monitor displays, etc., then disconnect them before welding. Failure to disconnect the sensitive electrical equipment could result in irreparable damage to these components.

Parts of the machine are made from cast iron; welds on cast iron can weaken the structure and break. Do not weld cast iron. Do not connect the welder cable or apply any weld to any part of the engine.

Always connect the welder earth (ground) cable to the same component that is being welded, i.e. boom or dipper, to avoid damage to pivot pins, bearings and

bushes. Attach the welder earth (ground) cable no more than 0.6 metres (2 feet) from the part being welded.

INT-3-1-15\_2

### WARNING

#### Counterweights

Your machine may be fitted with counterweights. They are extremely heavy. Do not attempt to remove them.

INT-3-2-5

### WARNING

Compressed air is dangerous. Wear suitable eye protection and gloves. Never point a compressed air jet at yourself or others.

0147\_1

---

#### WARNING

##### Accumulators

The accumulators contain hydraulic fluid and gas at high pressure. Prior to any work being carried out on systems incorporating accumulators, the system pressure must be exhausted by a JCB distributor, as the sudden release of the hydraulic fluid or gas may cause injury.

INT-3-1-17

---

#### WARNING

##### Petrol

Do not use petrol in this machine. Do not mix petrol with the diesel fuel; in storage tanks the petrol will rise to the top and form flammable vapours.

INT-3-1-6

---

#### CAUTION

Do not disconnect the battery while the engine is running, otherwise the electrical circuits may be damaged.

INT-3-1-14

---

#### WARNING

If you try to charge a frozen battery, or jump start and run the engine, the battery could explode. Do not use a battery if its electrolyte is frozen. To prevent the battery electrolyte from freezing, keep the battery at full charge.

0125

---

#### WARNING

##### Battery Gases

Batteries give off explosive gases. Keep flames and sparks away from the battery. Do not smoke close to the battery. Make sure there is good ventilation in closed areas where batteries are being used or charged. Do not check the battery charge by shorting the terminals with metal; use a hydrometer or voltmeter.

INT-3-1-8

---

#### DANGER

##### Electrolyte

Battery electrolyte is toxic and corrosive. Do not breathe the gases given off by the battery. Keep the electrolyte away from your clothes, skin, mouth and eyes. Wear safety glasses.

INT-3-2-1\_3

---

#### WARNING

##### Battery Terminals

The machine is negatively earthed. Always connect the negative pole of the battery to earth.

When connecting the battery, connect the earth (-) lead last.

When disconnecting the battery, disconnect the earth (-) lead first.

INT-3-1-9

---

#### CAUTION

Never use water or steam to clean inside the cab. The use of water or steam could damage the on-board computer and render the machine inoperable. Remove dirt using a brush or damp cloth.

8-3-4-8



---

### WARNING

#### Asbestos

Asbestos dust can damage your lungs. Some engine gaskets contain asbestos. Do not dismantle the engine or exhaust system; get these jobs done by a qualified person who has a copy of the engine service manual.

5-1-6-1

---

### DANGER

Before removing the boom from the machine, ensure that the counterweight is adequately supported as in certain ground conditions the machine could tip backwards. Never travel or transport the machine with the boom removed.

BF-6-3



## Safety Labels

### Introduction

#### **WARNING**

T1-014\_2

#### Safety Labels

**Safety labels on the machine warn you of particular hazards. You can be injured if you do not obey the safety instructions shown.**

INT-1-3-11

Safety labels are strategically placed around the machine to remind you of possible hazards.

If you need eye-glasses for reading, make sure you wear them when reading the safety labels. Do not over-stretch or place yourself in dangerous positions to read the safety labels. If you do not understand the hazard shown on the safety label, then refer to **Safety Label Identification**.

**Note:** *The illustration(s) show a typical machine model. Your machine may look different from the model shown.*

Keep all safety labels clean and readable. Replace lost or damaged safety labels. Make sure replacement parts include safety labels where necessary. Each safety label has a part number printed on it, use this number to order a new safety label from your JCB distributor.

### Safety Label Identification

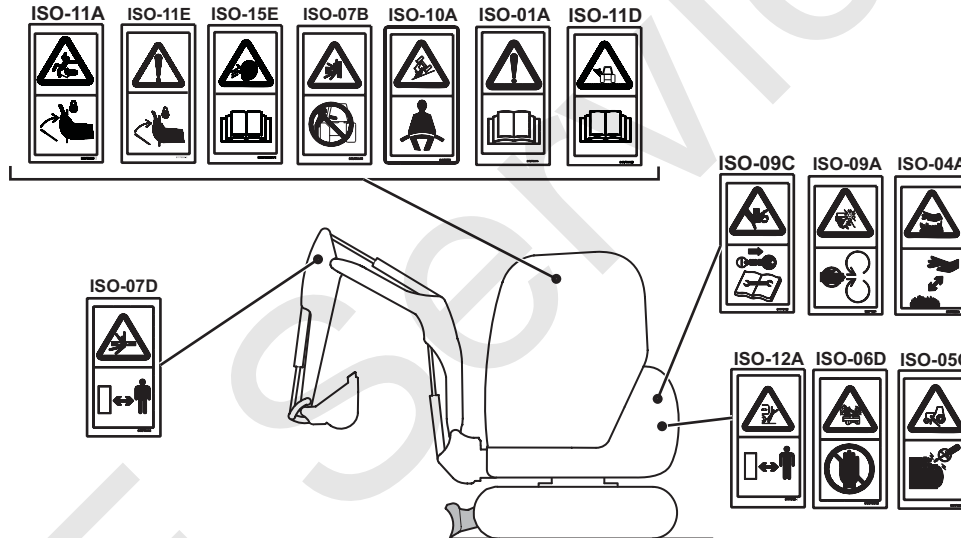

Fig 3.

T038750-3

### Part Numbers and Descriptions

#### ISO-01A

Part Number: 817/70014

Description: Warning. Read the operator manual before you operate the machine.

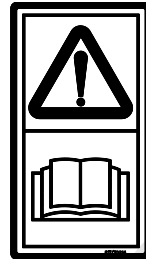

817-70014-3

#### ISO-04A

Part Number: 817/70004

Description: Burns to fingers and hands. Stay a safe distance away.



817-70004-4

#### ISO-05C

Part Number: 817/70012

Description: Runover. Start the engine from the operator seat only. Do not short across the terminals.



817-70012-2

### ISO-06D

Part Number: 817/70005

Description: Hot fluid under pressure. Refer to **Cooling System (Routine Maintenance Section)**.



817-70005-3

### ISO-07D

Part Number: 817/70112

Description: Crush hazard. Keep a safe distance from the moving parts.



817-70112-2

### ISO-07B

Part Number: 817/70018

Description: Crush hazard. Do not operate the controls from outside of the machine.



817-70018-2

### ISO-010A

Part Number: 817/70029

Description: Crush hazard. Wear the seatbelt when you operate the machine.



817-70029-3

### ISO-12A

Part Number: 817/70106

Description: Strike to whole body (machine swing). Keep a safe distance from the machine.



817-70106-2

### ISO-09C

Part Number: 817/70102

Description: Crushing of fingers or hands. Remove the starter key and refer to the Service Manual before you start maintenance work.

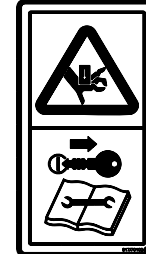

817-70102-3

### ISO-11D

Part Number: 817/70100

Description: Fall. Enter and dismount safely. Refer to **Entering and Leaving the Cab (Operation Section)**.



817-70100-2

### ISO-11E

Part Number: 817/70006

Description: Fall. Unexpected machine movement because of accidental contact with the machine controls if the hydraulic functions are not isolated..



817-70006-2

### ISO-15E

Part Number: 332/V3761

Description: Flying debris warning.  
Refer to **Optional Attachments**.



332-V3761-1

### ISO-11A

Part Number: 332/T9356

Description: Falling hazard. Lift the lever lock.



332-T9356-2

### ISO-09A

Part Number: 332/P4581

Description: Severing of hands or fingers. Keep clear of/do not reach into the moving parts. Stop the engine and remove the starter key before you start maintenance work. Refer to **Making the Machine Safe (Routine Maintenance Section)**.



332-P4581-1

## Identifying Your Machine

### Machine Identification Plate

Your machine has an identification plate mounted as shown. The Product Identification Number (PIN), weight, engine power, year of manufacture and serial number of the machine are shown on the plate.

**Note:** *The machine model and build specification is indicated by the PIN. Refer to **Typical Product Identification Number (PIN)**.*

If the engine is replaced by a new one, the serial number on the identification plate will be wrong. Either get a replacement identification plate from your JCB Dealer or simply remove the old number. This will prevent the wrong unit number being quoted when replacement parts are ordered.

The machine and engine serial numbers can help identify exactly the type of equipment you have.

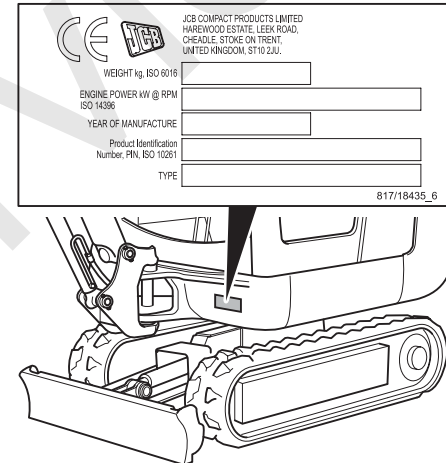

Fig 4.

772890-3



#### Typical Product Identification Number (PIN)

1	2	3	4
JCB	08025	L	01226500

- 1 World Manufacturer Identification (3 Digits).

JCB = UK Build.

- 2 Machine Type and Model (5 Digits).

08025 = 8025.

- 3 Random Check Letter (1 Digit).

The Check Letter is used to verify the authenticity of a machine's PIN.

- 4 Machine Serial Number (8 Digits).

Each machine has a unique serial number.



### Component Identification Plates

#### Typical Engine Identification Number

The engine data label is located on the cylinder block as shown. The data label includes the engine identification number.

A typical engine identification number is:

GJ	U	65692	500405	P
<b>1</b>	<b>2</b>	<b>3</b>	<b>4</b>	<b>5</b>

#### 1 Engine Type (2 Digits)

GJ = Naturally aspirated, 8026 CTS - 18.4kW

GJ = Naturally aspirated, 8025 ZTS, 8030ZTS - 20.9kW

GJ = Naturally aspirated, 8035ZTS - 23.6kW

#### 2 Country of Manufacture (1 Digit)

U = United Kingdom

#### 3 Build Number (5 Digits)

#### 4 Engine Serial Number (6 Digits)

#### 5 Year of Manufacture (1 Digit)

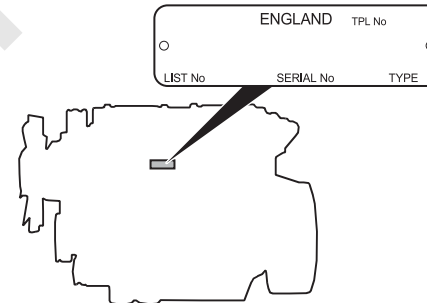

Fig 5.

T017650-2

### Identifying Your Machine

## ROPS, TOPS and FOGS

### WARNING

**Modified and wrongly repaired ROPS, TOPS & FOGS Structures are dangerous. Do not modify the TOPS Structure. Do not attempt to repair the ROPS, TOPS & FOGS Structure. If the ROPS, TOPS & FOGS Structure has been in an accident, do not use the machine until the structure has been inspected and repaired. This must be done by a qualified person. For assistance, contact your JCB dealer. Failure to take precautions could result in death or injury to the operator.**

5-3-1-7\_2

Machines built to ROPS and TOPS standards have an identification label fitted to the cab. ⇒ [Fig 6. \(□ 40\)](#).

A bolt on falling object guard is available which also carries a certified label. This label certifies the cab to FOGS standard. ⇒ [Fig 7. \(□ 41\)](#).

When a machine is used in an application with the risk of falling objects, the machine must be equipped with the optional FOGS guard. This guard is compliant to ISO10262 level 1 and is intended for protection from small objects, e.g. small rocks, small debris and other small objects encountered in operations such as highway maintenance, landscaping and other construction site services.



**Fig 6.**

### Identifying Your Machine

The falling objects protection structure (FOPS) is fitted with a dataplate. The dataplate indicates what level protection the structure provides.

There are two levels of FOPS:

- **Level I Impact Protection** - impact strength for protection from small falling objects (e.g. bricks, small concrete blocks, hand tools) encountered in operations such as highway maintenance, landscaping and other construction site services.
- **Level II Impact Protection** - impact strength for protection from heavy falling objects (e.g. trees, rocks) for machines involved in site clearing, overhead demolition or forestry.



Fig 7.

### FOPS Data Plate

#### **WARNING**

**Do not use the machine if the falling objects protection level provided by the structure is not sufficient for the application. Falling objects can cause serious injury.**

8-2-8-17

If the machine is used in any application where there is a risk of falling objects then a falling-objects protective structure (FOPS) must be installed. For further information contact your JCB Dealer

## Machine Security

### Introduction

Vandalism and theft of unattended machines is an ever increasing problem and JCB is doing everything possible to help combat this.

T1-019

Your JCB Distributor or Dealer will be pleased to provide information on any of these sensible precautions. ACT NOW!

### JCB Plantguard

JCB PLANTGUARD is a comprehensive package available to help you safeguard your machine. It includes such devices as vandal proof covers, window etching, immobiliser, concealed serial number, battery isolator, Tracker security system and much more.

Remember that the fitting of any one of these security devices will help to minimise not only the damage or loss

of your machine but also subsequent lost productivity. It could also result in reduced insurance premiums.

### Construction Equipment Security And Registration Scheme (CESAR)

T1-020

JCB are pleased to announce, the availability of CESAR a simple, effective method of machine identification and registration that operates throughout the United Kingdom and Ireland and across the whole spectrum of JCB products.

CESAR is a scheme to help reduce plant theft, and was developed by the Metropolitan Police and the Home Office Plant Theft Action Group.

The key to the scheme is its simplicity and will mean that every police officer in the country will know how to identify construction machinery and verify ownership. This will



provide a major leap forward in both protecting machinery, and recovering it.

The Construction Equipment Association is managing the scheme, and Datatag are providing the security material and support. JCB is fully supportive of the CESAR initiative and will offer it as a factory fit option across the range.

The CESAR kit includes 2 Tamper proof triangular ID plates fitted on either side of the machine, a unique transponder, mini radio frequency identification tags (RFIDs) concealed throughout the machine, Datatag micro dots, and a unique DNA coded chemical painted on the machines major components. Plus a registration certificate logged onto the CESAR or DVLA databases, and a change of keeper form.



## **Introduction**

Machine Security

**Page left intentionally blank**

---

# Operation

## Introduction

T2-006\_2

The aim of this part of the manual is to guide the operator step-by-step through the task of learning how to operate the machine efficiently and safely. Read the **Operation** section through from beginning to end.

Before you start the machine, you must know how the machine operates. Use your manual to identify each control lever, switch, gauge, button and pedal. Do not guess. If there is anything you do not understand, ask your JCB distributor.

The operator must always be aware of events happening in or around the machine. Safety must always be the most important factor when you operate the machine.

When you understand the operating controls, gauges and switches, practice using them. Drive the machine in an

open space, clear of people. Get to know the 'feel' of the machine and its driving controls.

Finally, do not rush the job of learning, make sure you fully understand everything in the **Operation** section. Take your time and work efficiently and safely.

Remember

BE CAREFUL

BE ALERT

BE SAFE

### Before Entering the Cab

P11-2005\_3

The following checks should be made each time you return to the machine after leaving it for any period of time. We advise you also to stop the machine occasionally during long work sessions and do the checks again.

All these checks concern the serviceability of the machine. Some concern your safety. Get your service engineer to check and correct any defects.

#### **WARNING**

**Walking or working under a raised boom and dipper is hazardous. You could be crushed by the boom and dipper or get caught in the linkages. Lower the boom and dipper before doing these checks. If you are new to this machine, get an experienced operator to lower the boom and dipper for you. If there is nobody to help you, study the Operator Manual until you have learned how to lower the boom and dipper.**

8-2-1-1\_2

- 1 Check for cleanliness.
  - a Clean the windows and light lenses.
  - b Remove dirt and debris, especially from around the linkages, rams, pivot points and radiator.
  - c Make sure the cab step and handrails are clean and dry.
  - d Clean all safety and instructional labels. Replace any that are missing or cannot be read.
- 2 Check for damage.
  - a Inspect the machine generally for damaged and missing parts.
  - b Make sure that the attachment is secure and in good condition.





## Operation

### Before Entering the Cab

- c Make sure that all pivot pins are secured correctly in place.
  - d Inspect the windows for cracks and damage. Glass splinters can blind.
  - e Check for oil, fuel and coolant leakages beneath the machine.
- 5 Make sure that all of the access panels are closed and secure.

**Note:** *If the filler caps and access panels are fitted with locks, we recommend that you lock them to prevent theft or tampering.*

### WARNING

**You could be killed or injured with damaged tracks. Do not use the machine with damaged or excessively worn tracks.**

MD-2-1-1

#### 3 Check the tracks (Rubber)

Check for cut rubber and penetration by sharp objects. Do not use a machine with damaged tracks.

#### 4 Make sure that all of the filler caps are installed correctly.

## Entering and Leaving the Cab

### WARNING

#### Entering/Leaving

Entering or leaving the cab or canopy must only be made where steps and handrails are provided. Always face the machine when entering and leaving. Make sure the step(s), handrails and your boot soles are clean and dry. Do not jump from the machine. Do not use the machine controls as handholds, use the handrails.

INT-2-1-7\_1

### WARNING

For safety reasons, machines fitted with single access canopies from new must not have the barrier removed. The machine must always be entered/exited with the left hand isolator raised via the left hand side.

8-2-9-22

### WARNING

Do not enter or exit the cab unless the arm rest or lever lock is fully engaged.

8-2-9-21

Make sure the machine is stopped and correctly parked before entering or leaving the cab. If necessary, refer to ***Stopping and Parking the Machine***.

To give sufficient clearance to enter or leave the cab, the left hand console must be raised. When the handle **A** and the left hand console are in the raised position the excavator controls cannot be operated (Track and Dozer controls are still active). Lowering the handle to the normal position connects the excavator controls and allows the normal operation of the levers.



When you get on or off the machine always maintain a three point contact with the handrails and step. Do not use the machine controls as handholds.

## Emergency Exit

### Glazing Breaker

Remove the glazing breaker **B** and strike the rear screen near the corner, this will shatter the screen which can then be knocked out.

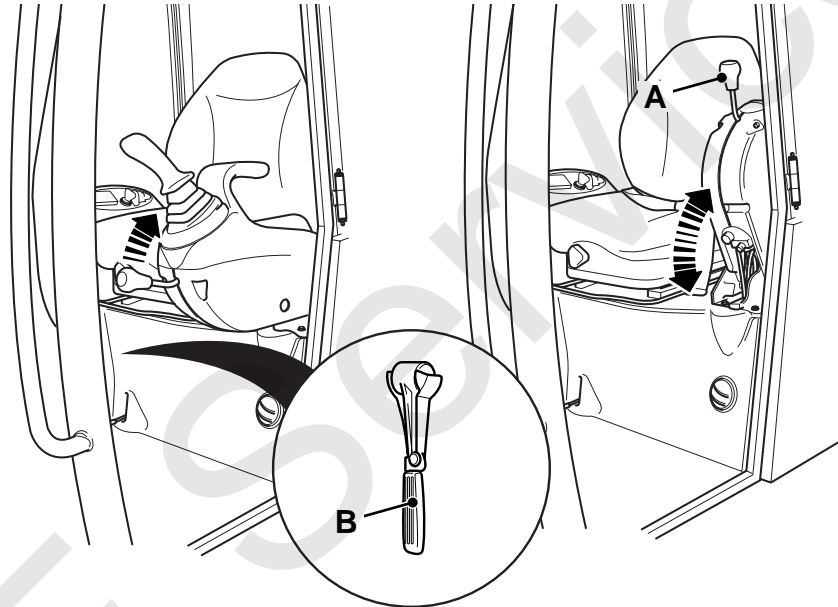
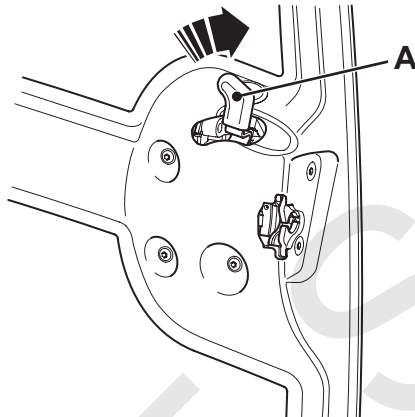

Fig 8.

## Doors and Windows

### Opening and Closing the Door



**Fig 9.**

To open the door from the outside, unlock it with the key provided and press the lock barrel to release the catch. Pull the handle towards you.

To open the door from inside, push lever **A** forwards.  
 ⇒ [Fig 9.](#) (□ 51).

Close the door from the inside by pulling it firmly, it will latch itself.

### CAUTION

**Do not drive the machine with the door unlatched. It must be correctly closed or secured fully open.**

8-2-1-2

## Securing the Door in the Open Position

The door can be secured in the fully open position.

Swing the door fully open until the spigot **A** on the door locates securely in the socket **B** on the side of the cab.

⇒ [Fig 10.](#) ([□ 52](#)).

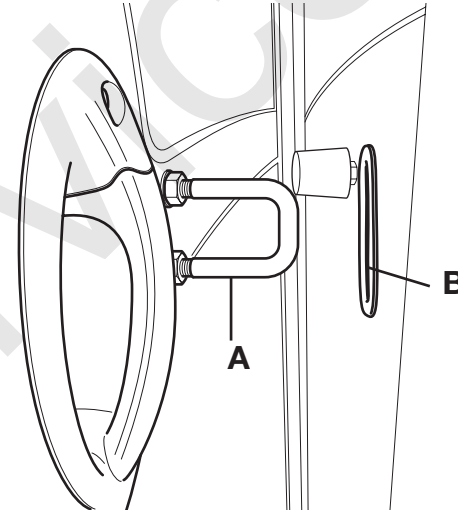

**Fig 10.**

804110

To release the door when it is secured fully open, pull the lever **C** up on the inside of the cab. ⇒ [Fig 11.](#) ([□ 53](#))

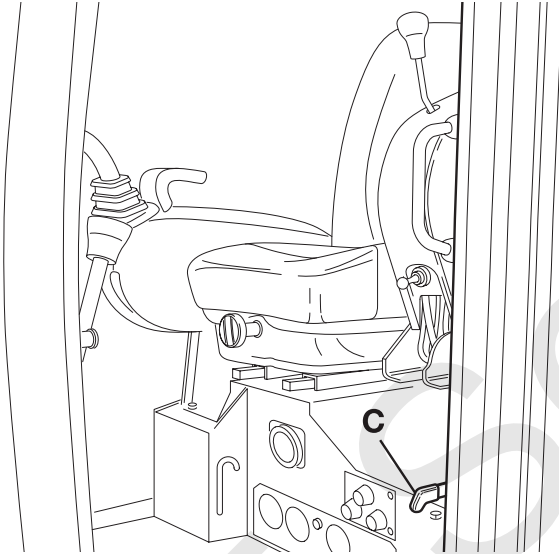

C035100

**Fig 11.**

### Opening and Closing the Front Window

P11-2024

#### CAUTION

Take care when raising and lowering the window; lower your head as you pull the window back. Isolate the hydraulic controls before opening and closing the window.

0120

To open the up and over window:

- 1 Hold handles **A**, press and hold down securing levers **B**.
- 2 Lift the screen into a position parallel with the roof using handles **A**, secure in position by releasing levers **B**.

**Note:** Care must be taken when lowering the window not to bump the top edge of the lower front window.

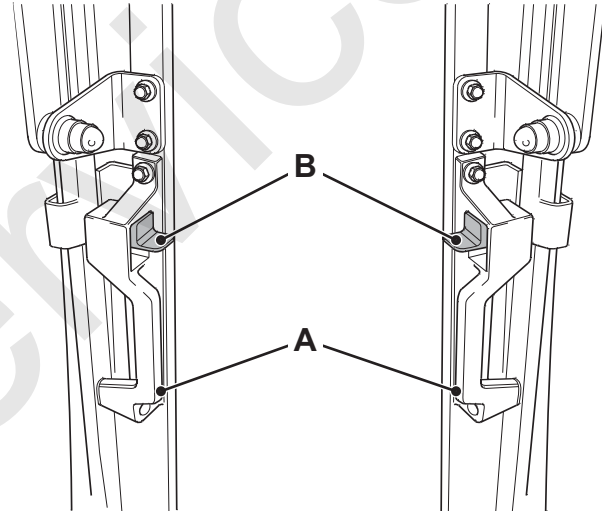

Fig 12.

732630-2



## Removing and Refitting the Windscreen Lower Panel

Make sure that the engine is stopped and the hydraulic controls are isolated.

Open the front window and secure it in a position parallel with the roof. ⇒ [Opening and Closing the Front Window \(□ 54\)](#).

### **WARNING**

When handling the removed windscreen lower panel, take care not to step backwards out of the cab through the windscreen aperture.

8-2-9-37

Slacken screws **C** and remove the retaining bar **D**. ⇒ [Fig 13. \(□ 55\)](#).

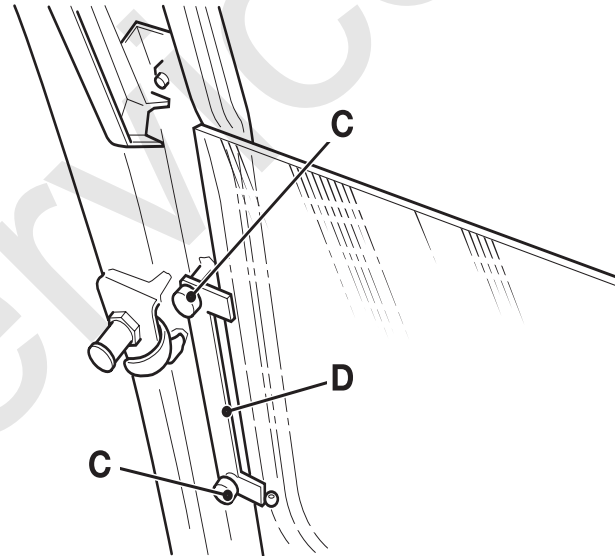

**Fig 13.**

C035120

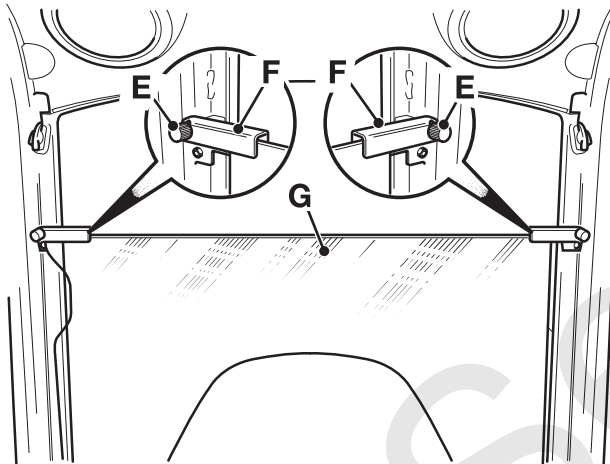

**Fig 14.**

C035130

Slacken screws **E** and turn retainers **F** to the raised position.

Carefully lift out the windscreen lower panel and stow it next to the rear window as shown at **G**. Turn retainers **F** to secure the panel and tighten screws **E**.

To refit the windscreen lower panel, reverse the removal procedure. Make sure the right hand edge of the panel is located firmly in the groove on the windscreen pillar before fitting retaining bar **D**. → [Fig 13.](#) (□ 55).

## Opening and Closing the Side Window

P11-2025

The side window is held closed by catch **A** operated from inside the cab.

To open the window, operate the catch **A** and slide the window to the desired position.

To close the window, slide the window fully shut and check that the catch **A** has located on the frame.

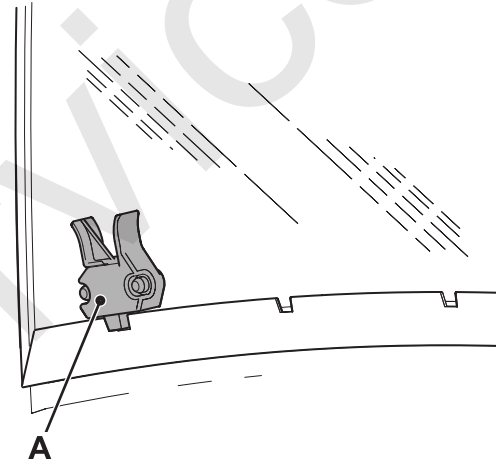

**Fig 15.**

807830-1

## Seat Controls

### Introduction

T2-007\_3

#### **WARNING**

##### Seat

**Position the seat so that you can comfortably reach the machine controls. Do not adjust the seat while the machine is moving. You could have an accident if you operate the machine with the seat in the wrong position.**

13-1-1-9\_1

The operator's seat can be adjusted for your comfort. A correctly adjusted seat will reduce operator fatigue. Position the seat so that you can comfortably reach the machine controls. For driving the machine, adjust the seat so that you can depress the pedals fully with your back against the seat back.

**Standard Seat**

The forward and backwards adjustment is adjusted using lever **B**.

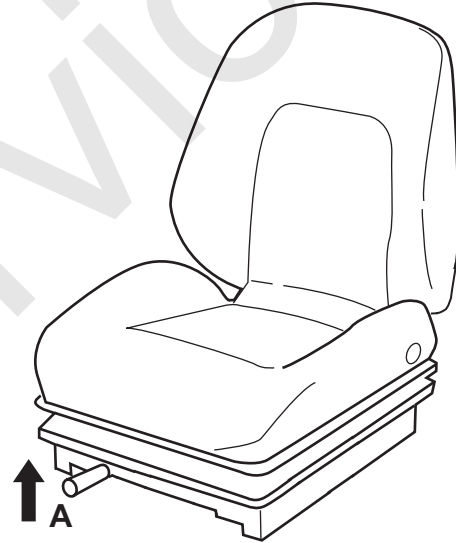
**Fig 16.**

T033180-1

**Suspension Seat (If fitted)**

The seat back rest can be adjusted by moving lever **A**.

The forward and backwards adjustment is adjusted using lever **B**.

Weight adjustment is adjusted by lever **C**.

The thigh support is adjusted by lever **D**.

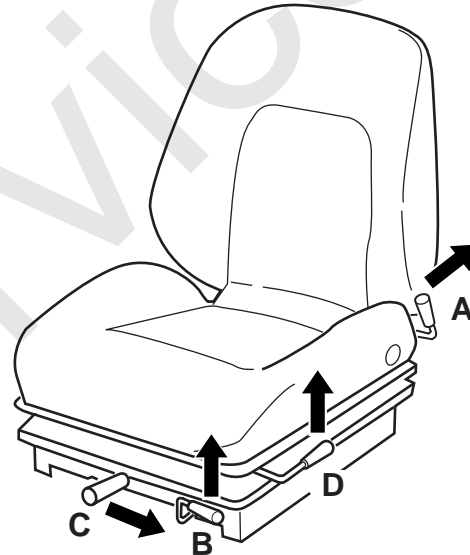
**Fig 17.**

T033180

## Seat Belt

### Static Seat Belt

#### **WARNING**

T2-002

If you do not wear your seat belt you could be thrown about inside the machine, or thrown out of the machine and crushed. You must wear a seat belt when using the machine. Fasten the seat belt before starting the engine.

8-2-9-2\_1

#### **WARNING**

When a seat belt is fitted to your machine replace it with a new one if it is damaged, if the fabric is worn, or if the machine has been in an accident. Fit a new seat belt every three years.

2-3-1-7\_1

### Fasten the Seat Belt

- 1 Sit correctly in the seat.
- 2 Push the male fitting **A** into the buckle **B** until it latches into position. Make sure the seat belt is not twisted and that it is over your hips not your stomach.

#### **WARNING**

If the seat belt does not 'lock' when you check if the seat belt is operating correctly, do not drive the machine. Get the seat belt repaired or replaced immediately.

2-2-2-1

**Release the Seat Belt** **WARNING**

Release the seat belt only after switching off the engine.

2-2-1-10

Press button **C** and pull the male fitting **A** from the buckle **B**.

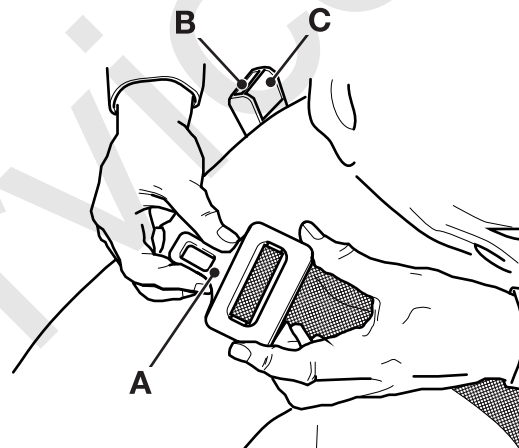

**Fig 18.**

**Adjusting the Seat Belt**

Make sure the belt is across your hips and not over your stomach.



To adjust the male fitting **A**:

- 1 Pull toggle **D** down the strap by the required distance.
  - a To make the strap longer, pull end **E** as far as it will go.
  - b To make the strap shorter, pull end **F** as far as it will go.

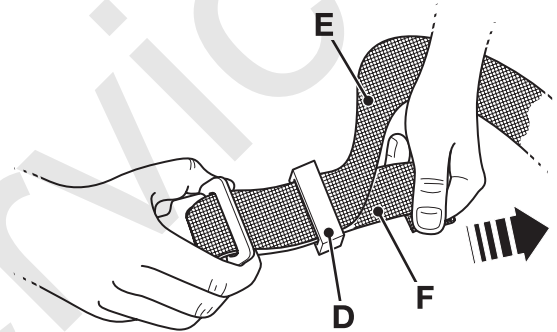

Fig 19.

### Cab Layout

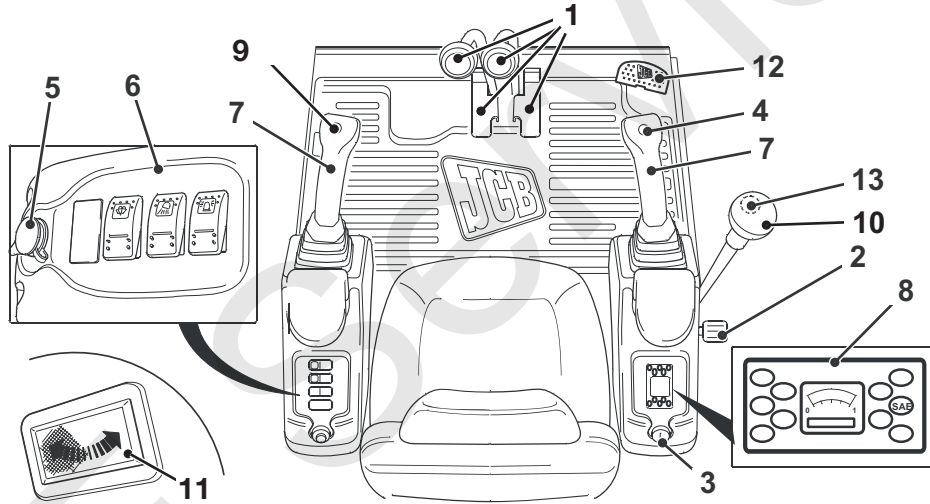

Fig 20.

C019600-1

## Component Key

- 1 ⇒ [Track Controls \(□ 66\)](#).
- 2 ⇒ [Hand Throttle Lever \(□ 69\)](#).
- 3 ⇒ [Starter Switch \(□ 72\)](#).
- 4 ⇒ [Horn \(□ 74\)](#).
- 5 ⇒ [Auxiliary Power Socket \(□ 73\)](#).
- 6 ⇒ [Console Switches \(□ 70\)](#).
- 7 ⇒ [Excavator Controls \(□ 82\)](#).
- 8 ⇒ [Instrument Panel \(□ 75\)](#).
- 9 ⇒ [Swing/Auxiliary Switch \(□ 74\)](#).
- 10 ⇒ [Dozer Controls \(□ 90\)](#).
- 11 ⇒ [Cab Interior Light \(□ 73\)](#).
- 12 ⇒ [Swing Pedal \(□ 88\)](#).
- 13 ⇒ [Two Speed Tracking Switch \(□ 74\)](#).

## Drive Controls, Switches and Instruments

### Drive Controls

#### Track Controls

P11-2021

The two tracks are controlled by a pair of control levers **A** in front of the seat. Each lever controls one track and is spring loaded to a central position. In this position the track does not operate. The left side lever controls the left track. The right side lever controls the right track. The two levers can be operated individually or together as necessary to move the machine as required. This can be done using one hand or both.

The track controls operate as described when the excavator is positioned about the dozer **B**. If the excavator is at the opposite end to the dozer, the lever operation will be reversed. Always travel the machine with the excavator positioned at the same end as the dozer, especially on hard and rocky ground.

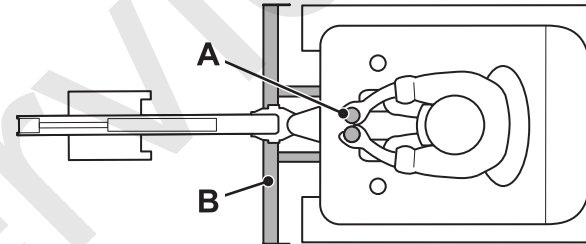
**Fig 21.**

731911-4

### Driving the Machine

#### DANGER

##### Drive Safely

Drive the machine smoothly. Spin turn manoeuvres, zig-zag driving or turning too fast can cause the vehicle to overturn.

8-1-2-2\_2

#### WARNING

When the cab is swung around so that it is facing the track motor end of the undercarriage, the action of the tracking controls is reversed. Take extra care!

8-2-8-1

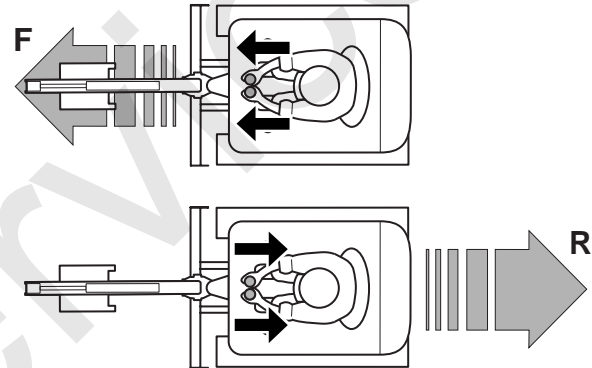

731911-5  
**Fig 22. Moving the Machine Forward or Backward**

To move the machine forward, push both levers forward (Direction F). Release the levers to stop.

To move the machine backward, pull both levers backward (Direction R). Release the levers to stop.

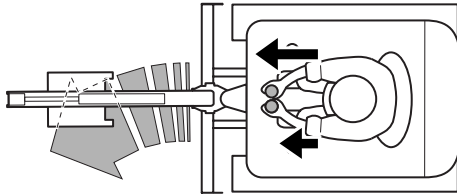

**Fig 23. Turning the Machine**

731911-7

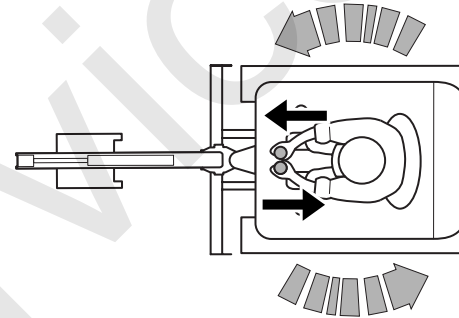

**Fig 24. Spinning the machine**

731911-8

To turn the machine while you travel, move the lever back towards the central position on the side towards which you want to go e.g. move the left lever back to turn left. This causes one of the tracks to move slower than the other. The faster moving track will push the machine around. Release the lever to stop.

To spin the machine around through 360°, without moving it, operate one lever, in a forward position and the other in a reverse position. This will cause the tracks to drive in opposite directions and hence push the machine around.

### Hand Throttle Lever

A hand-operated throttle lever in the cab controls the speed of the engine. → [Fig 25.](#) ([□ 69](#)).

Move the lever **A** to increase or **B** to decrease the engine speed. The lever can be left in any position between idle and maximum as required.

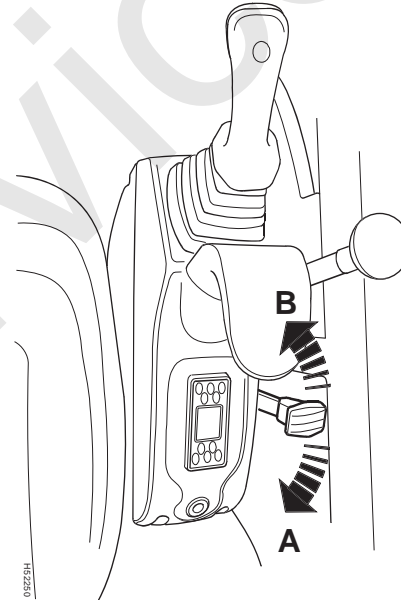

Fig 25.

C019920-1

### Switches

#### Console Switches

##### Introduction

The installed switches and their positions can change according to the specification of the machine.

Each switch has a graphic symbol **A** to show the function of the switch. Before you operate a switch, make sure that you understand its function.

The rocker switches have two or three positions (as shown).

If the switch is active, then the light **B** will come on to show that the switch function is active.

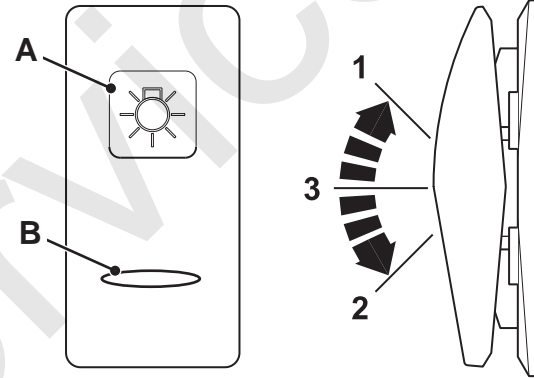

**Fig 26.**

T042100-2



### Console and Seat Switches

#### Beacon



339711-1

Two position rocker switch. The switch functions operate when the starter switch is in the ON and OFF positions.

Position 1: OFF

Position 2: ON

Before you operate the switch, refer to **Beacon**.

#### Work Lights



340100-1

Two or three position rocker switch. The switch functions operate when the starter switch is in the ON position.

Position 1: OFF

Position 3: Boom and cab work lights ON  
(Cab machines only)

Position 2: Boom work light ON

#### Rear Window Wiper (if fitted)

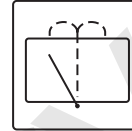

340070-1

Three position rocker switch. The switch functions operate when the starter switch is in the ON position.

Position 1: OFF

Position 3: ON

Position 2: Washer ON (if fitted)

**Note:** The wiper will self-park when switched off.

#### Overload Warning Switch (if fitted)

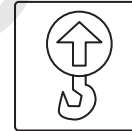

T034110-2

Two position rocker switch. The switch functions operate when the starter switch is in the ON position.

Position 1: OFF

Position 2: ON

Before you operate the switch, refer to **Overload Warning System (if Fitted)**.

### Starter Switch

T2-071\_2

This is operated by the starter key. It has four positions. The key can be removed only with the switch set to **0**.

- 0** Turn the key to this position to stop the engine. Make sure the controls are in neutral and the excavator and dozer are lowered before stopping the engine.
- I** Putting the switch to this position connects the battery to all the electrical circuits. The starter key will spring back to this position when it is released from **II** or **III**.
- II** Holding the key in this position switches on the glow plugs. The glow plugs warm the engine combustion chambers for cold weather starting. Do not hold in this position for more than 60 seconds.
- III** Operates the starter motor to turn the engine.

**Note:** Do not operate the starter motor for more than 10 seconds without the engine firing. If the engine fires but

does not fully start, allow the starter motor to cool for at least two minutes between starts.

**Note:** The starter switch has an inhibitor to stop the switch being turned ON when the engine is running. If the engine fails to start, the switch needs to be returned to position **0** before re-engaging the starter.

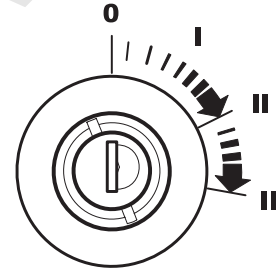

Fig 27.

H04432-2

#### Cab Interior Light

T2-020

Press either end of the light unit **A** to switch on the cab interior light. Pressing the other end will switch the light off.

Make sure the light is turned off when you intend to leave the machine for a long period of time.

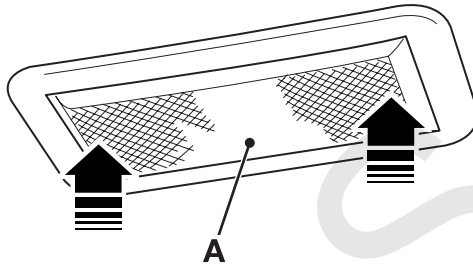

Fig 28.

C007130-1

#### Auxiliary Power Socket

The socket **X** supplies a 12 Volt DC power supply to electrical accessories (from the battery). Only connect items which are compatible with the power rating of the socket (Refer to **Electrical System, Fuses**) and have the correct plug.

Always operate the engine during prolonged use of electrical accessories, otherwise the battery can discharge.

Make sure that the socket cap is closed when the socket is not in use.

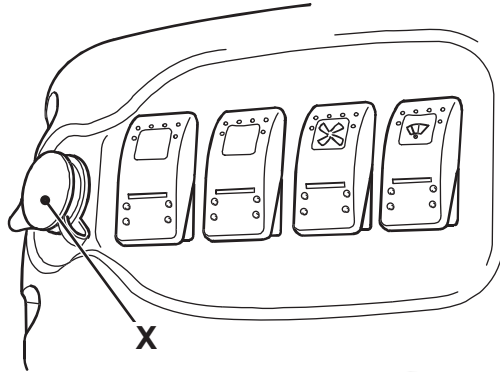

Fig 29.

#### Horn

The horn button is on the right hand excavator control lever. Push the button to operate the horn. It functions only with the starter switch set to on.

#### Swing/Auxiliary Switch

There is a push button switch located in the left hand excavator control lever. Press the switch to set the swing/auxiliary pedal to control either swing or auxiliary services. For more information, refer to ***Excavator Controls*** and ***Auxiliary Operation***.

#### Two Speed Tracking Switch

An increase in speed can be achieved by operating the two speed tracking push button switch located in the dozer lever.

For more information, refer to ***Getting the Machine Moving***.

### Instrument Panel

Indicators for the engine and related systems are mounted in the instrument cluster in the R.H. console.  
⇒ [Fig 30. \(□ 76\)](#).

- 1 Charge (Fault) Indicator. Indicates Alternator operation. Illuminates RED when a fault occurs.
- 2 Coolant Temperature (High) Indicator. Illuminates RED when coolant temperature is too high.
- 3 Engine Oil (Low) Indicator. Illuminated RED when engine oil pressure is too low.
- 4 Two Speed (High Engaged) Indicator. Illuminated GREEN when high speed is engaged.
- 5 SAE Controls (Selected) Indicator. Illuminates GREEN when SAE control pattern is selected.
- 6 Glow Plugs (On) Indicator. Illuminates YELLOW when the Glow Plugs are energised.

### Drive Controls, Switches and Instruments

- 7 Air Filter (Blocked) Indicator. Illuminates YELLOW when the air filter is blocked.
- 8 Indicator not fitted to this machine.
- 9 Hourmeter. Records the total running time of the engine.  
Flashing hour glass icon indicates the hourmeter is accumulating time.
- 10 Fuel Indicator. ⇒ [Digital LCD Fuel Gauge \(□ 77\)](#).
- 11 Auxiliary Service (Selected) Indicator. Illuminates when the swing/auxiliary switch is selected to Auxiliary. When not illuminated swing is selected.
- 12 Indicator not fitted to this machine.

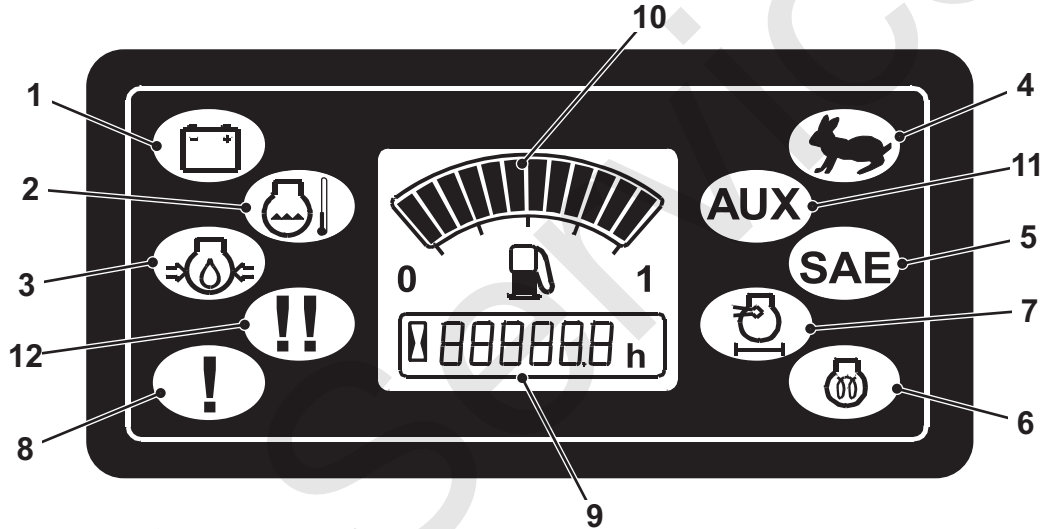

Fig 30.

445991-B6

### Digital LCD Fuel Gauge

T2-008\_2

Shows the amount of fuel in the fuel tank. Functions only with the starter switch set to ON.

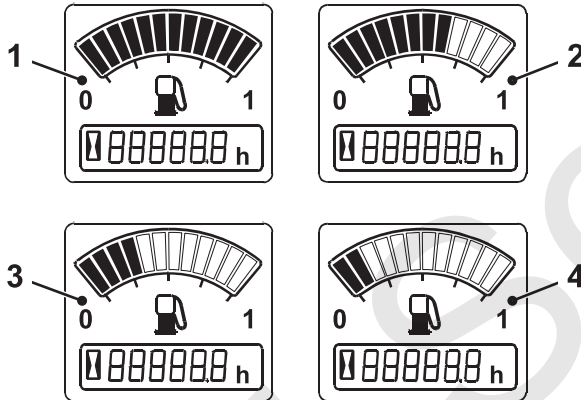

Fig 31.

- 1 Full Tank  
All bars illuminated. Pump symbol illuminated
- 2 4 bars to Full  
Pump symbol illuminated. All bars illuminated and reducing as level drops ie. 11 bars, 10 bars, 9 bars etc.
- 3 4 bars to 3 bars  
Buzzer gives 3 short beeps. Pump symbol starts to flash.
- 4 3 bars to 1 bar  
Pump symbol remains flashing. 1 bar illuminated (nearly empty). 0 bars illuminated (tank empty).

*Note: The flashing of all fuel level bars and the filler pump symbol indicates a fault in the fuel sender circuit. Contact your JCB dealer.*

### Warning Indicators

#### CAUTION

**If any of the audible/visual warnings operate while the engine is running, stop the engine as soon as it is safe to do so and rectify the fault.**

4-2-1-2

A buzzer will sound if any warning indicators **1**, **2** or **3** display a machine fault. → [Instrument Panel \(□ 75\)](#).

If the fault is ignored the buzzer will sound continuously for 180 seconds, after which it will sound intermittently, one second on, two seconds off.

Set the starter key to the off position to reset all operations.

- 1** Charge (Fault) Indicator  
Audible/Visual. Indicates Alternator operation. Illuminates RED when a fault occurs.
- 2** Coolant Indicator (On)  
Visual. Illuminates when the engine coolant overheats. The light should go out when the engine is started.
- 3** Engine Oil Pressure (On)  
Visual. Illuminates if the engine oil pressure drops too far. The light should go out when the engine is started.



### Heater and Air Conditioning (If fitted)

- 1 On/Off
- 2 Heat
- 3 Three speed fan

**Note:** The air intake filter **F** should be washed in warm, soapy water if it becomes dirty.

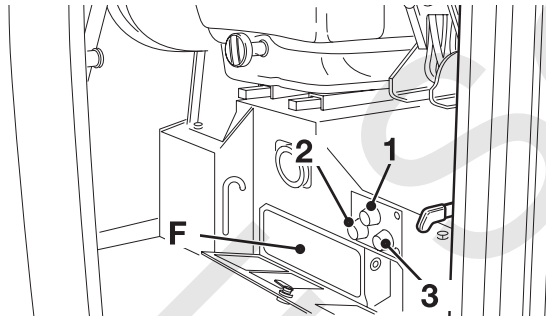

Fig 32.

### Cab Heater Controls

Air can be directed into the cab by selecting the required fan speed using switch **A**. Temperature control is by means of rotary dial **B**.

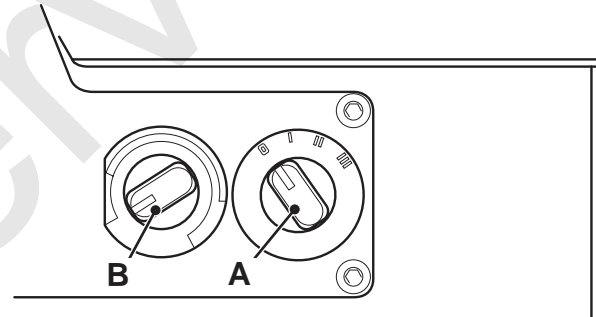

Fig 33.

## Operating Levers/Pedals

### Introduction

---

#### **WARNING**

##### Controls

You or others can be killed or seriously injured if you operate the control levers from outside the machine. Operate the control levers only when you are correctly seated.

0179\_2

---

#### **WARNING**

Make sure it is clear overhead before raising the boom. Keep an adequate safe distance from all electrical power lines. Contact your local power company for safety procedures.

5-2-1-5\_1

### Control Layouts

---

#### **WARNING**

Control lever/switch action may vary on machines, instructional labels near the levers/switches show by symbols, which levers/switches cause what actions. Before operating control levers/switches check the instructional label to make sure you select the desired action.

5-2-2-9\_2

Control levers and switches may vary on machines.



**Page left intentionally blank**

### Operating Levers/Pedals

## Excavator Controls

### WARNING

#### Controls - ISO/SAE

**Before operating the excavator controls always check to see which control pattern has been selected. Operate the machine slowly until you are familiar with the pattern selected. If the pattern selection indicator lamp is not illuminated, Do not operate the machine until any faults have been rectified.**

8-2-9-16

The excavator controls consist of the excavator levers **A** and the swing pedal **B**. → [Fig 34. \(□ 83\)](#).

A switch **C**, in the fuse panel, allows the operator to select either the ISO or SAE excavator control pattern. One of the indicator lamps **D** illuminates to show which pattern has been selected.

The excavator levers are spring loaded to the central position. In this position related services will not operate.

The speed and movement of the associated hydraulic function depends on how far you move the lever - the further you move the lever, the faster the action.

**Note:** *The boom ram incorporates damping at the limit of boom raise, reducing the speed of the ram and eliminating shock loadings.*

Raising the left armrest when leaving the cab prevents the services operating. When re-entering the cab, ensure the armrest is replaced firmly to ensure correct operation.

Most excavating movements are achieved using a combination of both the levers and the pedals at the same time. Practice such movements until you are familiar with the operations that can be achieved safely.

Ensure the slew lock is unlocked before operating the excavator controls. → [Control Locks \(□ 94\)](#).

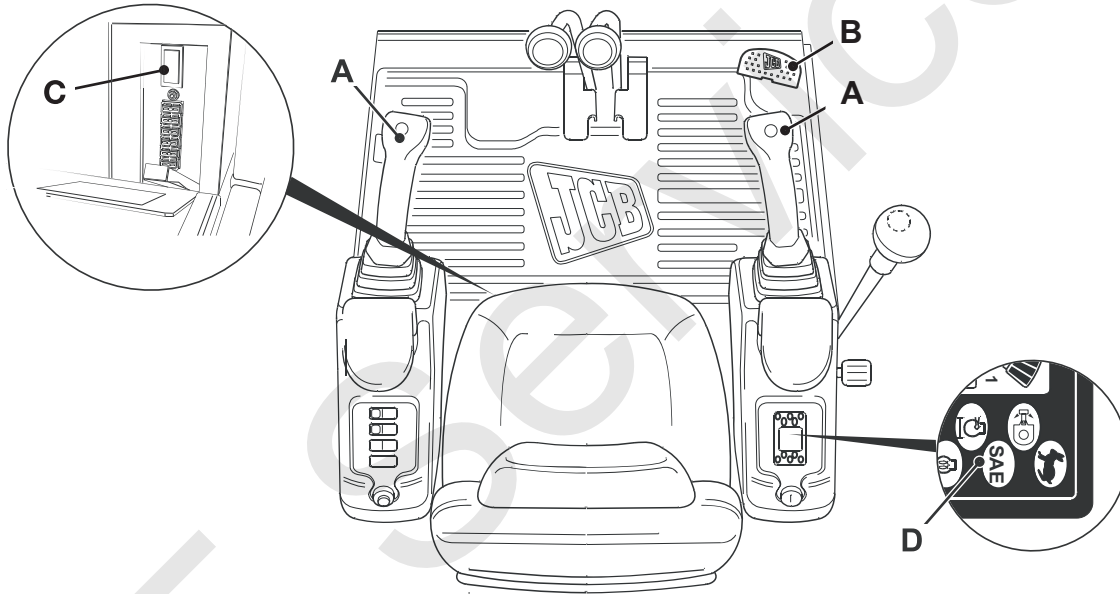

Fig 34.

C035010-3

### Excavator Levers (ISO Control Pattern)

- A Slew cab left
- B Slew cab right
- C Raise boom
- D Lower boom
- E Dipper in
- F Dipper out
- G Close bucket (to gather a load)
- H Open bucket (to dump a load)
- J Swing boom. Refer to **Swing Pedal**.

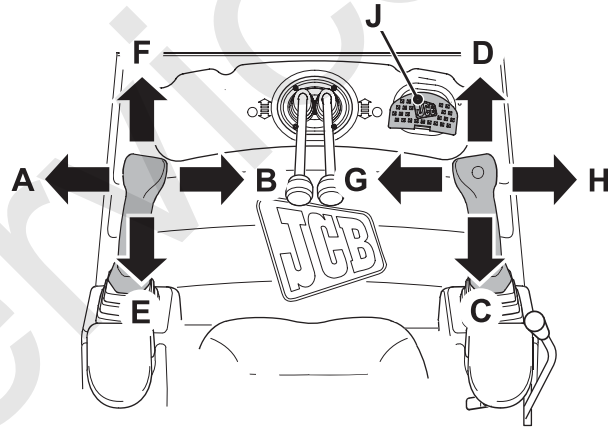

Fig 35.

731911-11

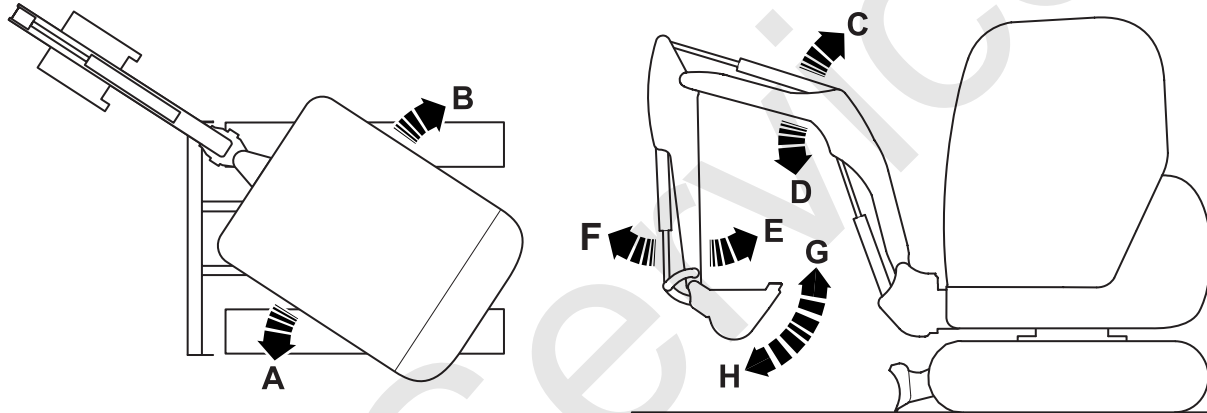

Fig 36.

731911

### Excavator Levers (SAE Control Pattern)

- A Slew cab left
- B Slew cab right
- C Raise boom
- D Lower boom
- E Dipper in
- F Dipper out
- G Close bucket (to gather a load)
- H Open bucket (to dump a load)
- J Swing boom. Refer to **Swing Pedal**.

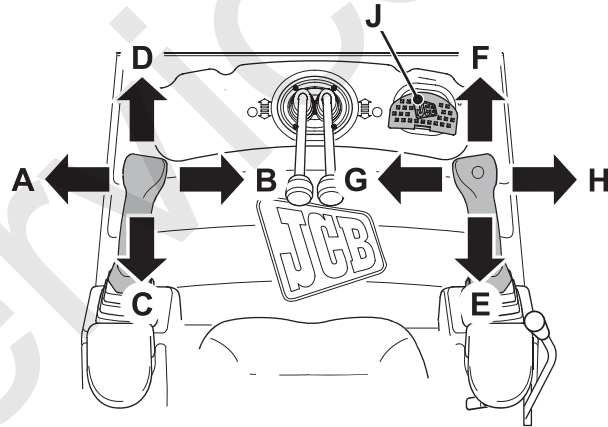

Fig 37.

731911-2



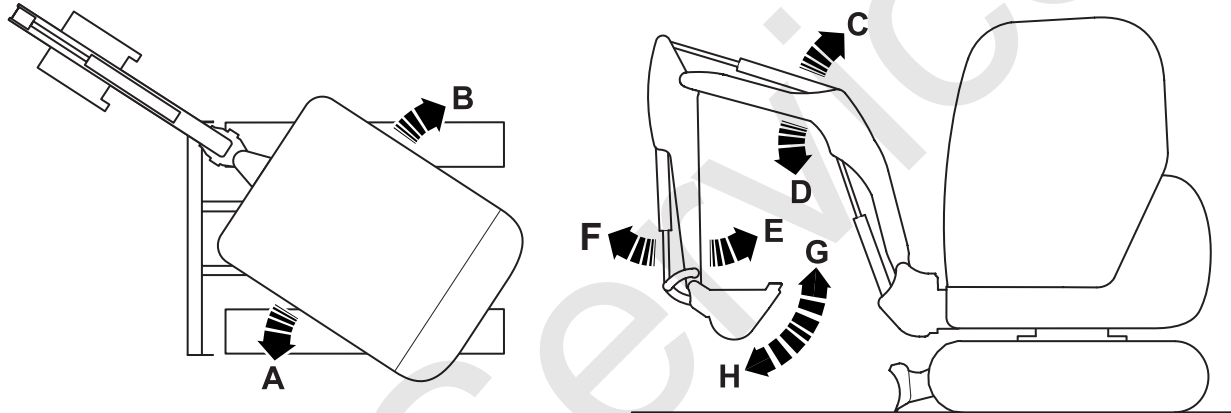

Fig 38.

731911

### Operating Levers/Pedals

#### Swing Pedal

#### WARNING

Ensure that the swing/auxiliary switch is set to the desired position before operating the swing/auxiliary pedal.

8-2-9-39

#### CAUTION

The swing pedal must be in the locked position when not in use.

8-2-9-29

To swing the boom to your left **A**, make sure that the swing/auxiliary switch **C** is selected to swing.

Press the swing / auxiliary pedal **D** to the left side. Release the pedal when the excavator end has reached the desired position.

To swing the boom to your right **B**, make sure that the swing / auxiliary switch **C** is selected to swing, press the swing / auxiliary pedal **D** to the right side. Release the pedal when the excavator end has reached the desired position.

**Note:** Every time the swing/auxiliary switch **C** is operated the respective swing/auxiliary indicator will illuminate (if fitted).

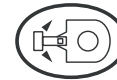

**Fig 39. Swing indicator illuminated (if fitted).**

**Important:** The swing/auxiliary switch **C** will always default to the swing position whenever the starter switch is turned from the 'O' position to the 'I' position.

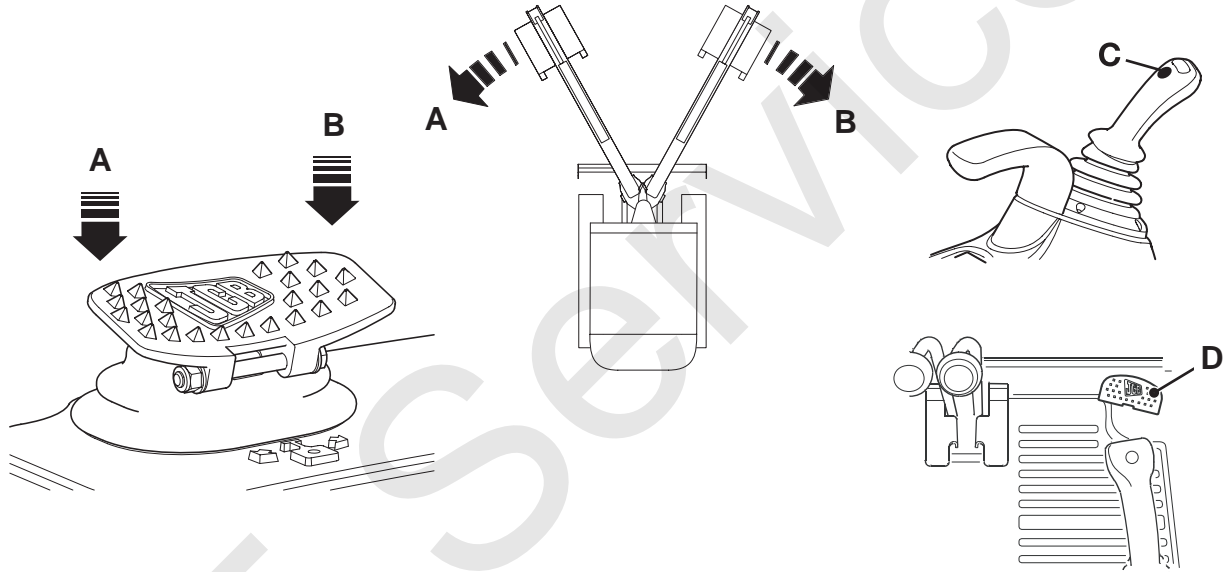

Fig 40.

796300-B3

## Dozer Controls

### CAUTION

**Before operating the dozer, make sure that large rocks or other objects are not between it and the tracks that can jam the mechanism.**

MD-2-1-5

The dozer is operated by a single control lever **C** on the right side of the cab. → [Fig 41.](#) ([□ 91](#)).

The lever is spring loaded to the central position. In this position the dozer will not move.

### Raise Dozer 'A'

To raise the dozer pull the lever backward. At the required position release the lever.

### Lower Dozer 'B'

To lower the dozer push the lever forward until an increased resistance is felt and the blade moves. At the required position release the lever.

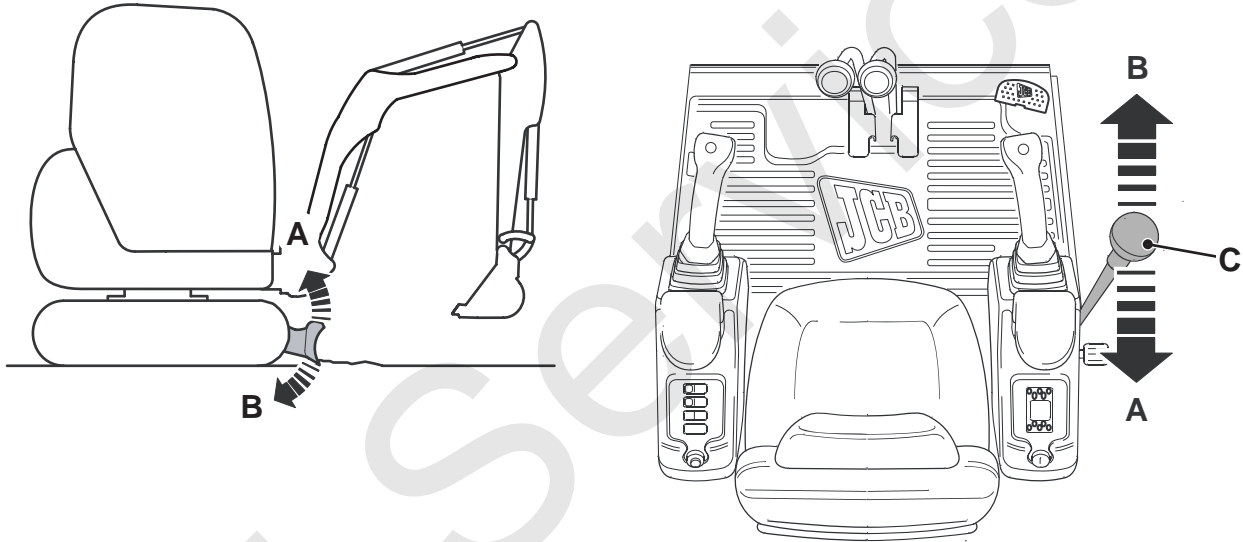

Fig 41.

C019940-2

### Operating Levers/Pedals

## Auxiliary Operation

### WARNING

Before operating the Auxiliary control system make sure that you are aware of all **WARNINGS** and **CAUTIONS** that apply to the attachment you are using. Also make sure you have fitted the attachment correctly. (See **OPTIONAL ATTACHMENT** section).

5-2-2-6

### WARNING

Ensure that the swing/auxiliary switch is set to the desired position before operating the swing/auxiliary pedal.

8-2-9-39

Make sure that the swing/auxiliary switch **C** is selected to auxiliary position. ⇒ [Fig 43.](#) ([□ 93](#)).

Press the swing/auxiliary pedal **D** to the left **A** or right **B** depending on the attachment fitted and the function required.

**Note:** Every time the swing/auxiliary switch **C** is operated the respective swing/auxiliary indicator will illuminate.

**Important:** The swing/auxiliary switch **C** will always default to the swing position whenever the starter switch is turned from the 'O' position to the 'I' position.



Fig 42. Auxiliary indicator illuminated.

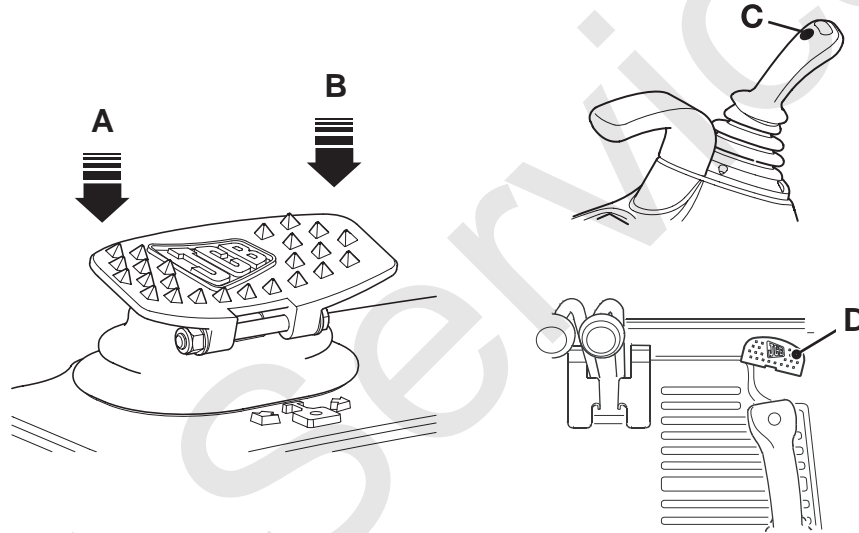

Fig 43.

796300-B4

## Safety Equipment

### Control Locks

#### **WARNING**

The boom/slew lock must be engaged when travelling on road or trailer, otherwise the boom could swing to one side and cause injury or death.

8-2-9-41

#### Slew Lock

The slew lock is situated in the seat bulkhead, → [Fig 44.](#) ( 94). Lift and move to the desired position.

- X position (Unlocked).
- Y position (Locked).

**Note:** Ensure the slew lock is unlocked before operating the excavator controls

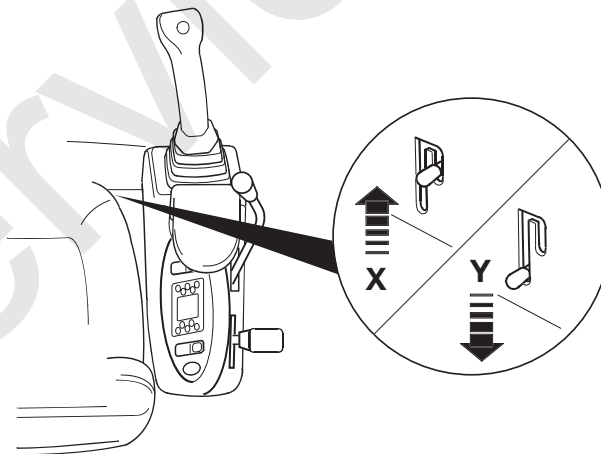

**Fig 44.**

731910-4



### Beacon

In certain territories you will be breaking the law if you do not fit a rotating beacon before you travel on public highways - make sure you are complying with local laws.

**Note:** Be careful when you operate the machine with a beacon. The total height of the machine is increased when the beacon is in the operating position.

1 Put the beacon **A** on the cab roof.

**Note:** The beacon is held in position by a magnetic base.

2 Put the plug **B** into the cab roof socket **C**.

3 Use the switch **D** to operate the beacon. The indicator light in the switch comes ON when the beacon is operating.

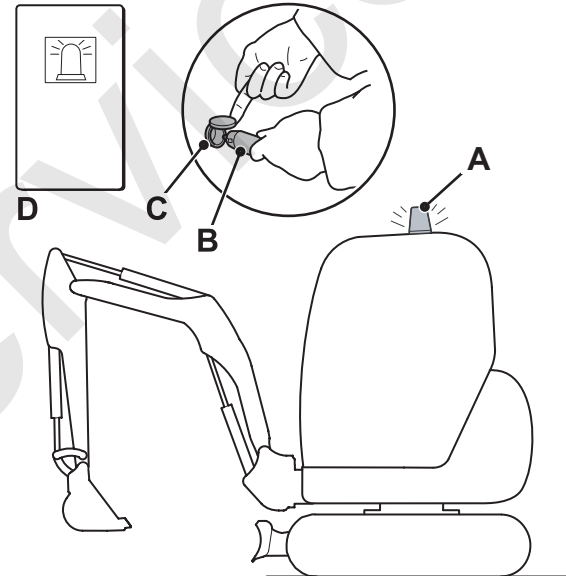

Fig 45.

732010-6

## Overload Warning System (If fitted)

The overload warning system senses the pressure in the boom raise pressure circuit, and gives an audible warning when the pressure exceeds the predetermined limits and there is a risk that the machine could become unstable.

When the machine is used for lifting, the system must be switched ON. To operate the system push the overload warning switch **A**. When the system is active the lamp in the switch is illuminated. ⇒ [Fig 46.](#) ([□ 96](#)).

If the safe operating lift limit is exceeded the buzzer will sound. When the buzzer sounds, the operator must do the necessary corrective action to reduce the lift. When this is fulfilled, the buzzer is cancelled and the system resets automatically.

When the machine is not used for object handling the system must be switched OFF, (the overload warning switch is not illuminated) otherwise the buzzer will sound during digging operations.

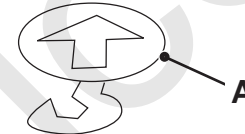

**Fig 46. Overload warning system active (If fitted)**

T034110

### **⚠ WARNING**

**When the overload protection system buzzer sounds, you must decrease the machine lift. If you do not decrease the machine lift a stability hazard could occur. When the machine is in a safe position the buzzer stops.**

8-2-8-21

All lifting operations must be done in accordance with local lifting regulations. ⇒ [Lifting \(Object Handling\)](#) ([□ 125](#)).

**Fire Extinguisher (If fitted)****Location**

The fire extinguisher **A** is located in the front of the cab and is held in position by a stowage bracket. Keep the fire extinguisher in this position until you need to use it.

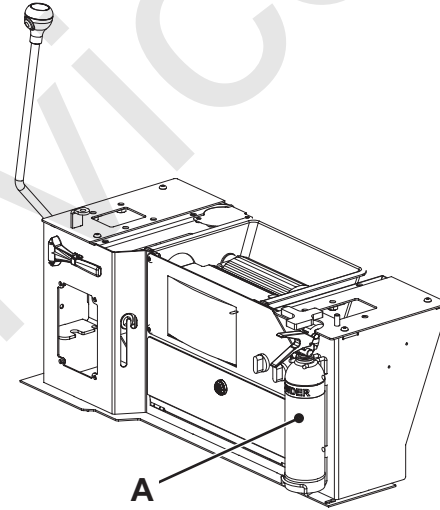
**Fig 47.**

T059050-1

## Operation

### **WARNING**

T2-041\_3

**Do not use the fire extinguisher in a confined space. Make sure that the area is well ventilated during and after using the fire extinguisher.**

4-2-3-1

### **WARNING**

**After any use, the extinguisher should be replaced or serviced.**

4-2-3-2

Make sure that you understand how to use the fire extinguisher. If necessary, refer to the instructions found on the fire extinguisher.

Only try to extinguish a fire if the circumstances permit and your safety is not endangered. If necessary, contact your nearest fire department.

Using the fire extinguisher:

- 1 If the circumstances permit and your safety is not endangered, move the machine to a safe place to prevent the fire from spreading.
- 2 Remove extinguisher from its stowage bracket.
- 3 Remove safety pin **A**.
- 4 Aim directly at the fire from an upwind position, if possible.
- 5 Squeeze trigger **B** to operate the extinguisher, release the trigger to stop the flow.

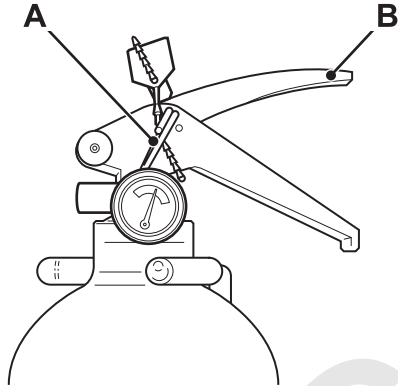

**Fig 48.**

S170520-3

The fire extinguisher should be inspected daily. Refer to ***Routine Maintenance, Fire Extinguisher (if fitted).***

### Before Starting the Engine

P11-2002\_2

**Note:** Read **Operating in Low Temperatures** or **Operating in High Temperatures** in Operation section if you will be using the machine in very cold or very hot climates.

**Note:** If the fuel tank has been empty or if any part of the fuel system has been drained or disconnected, the fuel system must be primed before attempting to start the engine. See **Bleeding the System**, Maintenance section.

#### DANGER

Before lowering the attachments to the ground, make sure that the machine and the area around it are clear of other people. Anyone on or close to the machine could fall and be crushed by the attachments, or get caught in the linkages.

2-2-3-4

- 1 Lower the excavator bucket and dozer to the ground, if they are not already there. They will lower themselves under their own weight when you operate the controls. Operate the controls carefully to control the rate of descent.

#### CAUTION

On machines fitted with hose burst protection valves the attachments cannot be lowered with the engine stopped. On these machines start the engine and lower the attachments before doing the walk round inspection.

2-2-3-5

- 2 For your own safety (and others) and for a maximum service life of your machine, do a pre-start inspection before starting the engine.

### Before Starting the Engine

- a If you haven't already done it, do a walk round inspection of the outside of the machine. See ***Before Entering the Cab.***
- b Remove dirt and rubbish from the cab interior, specially around the pedals and control levers.

#### **WARNING**

**Keep the machine controls clean and dry. Your hands and feet could slide off slippery controls. If that happens you could lose control of the machine.**

2-2-3-6

- c Remove oil, grease and mud from the pedals and control levers.
- d Make sure that your hands and shoes are clean and dry.

#### **WARNING**

**Loose articles can fall and strike you or roll on the floor. You could be knocked unconscious, or the controls could get jammed. If that happens you could lose control of the machine.**

2-2-3-7\_1

- e Remove or secure all loose articles in the cab - such as lunch boxes, tools etc.
- f Inspect the ROPS/TOPS/FOGS structure for damage. Get your JCB Distributor to repair any damage. Make sure all its securing bolts are fitted and correctly tightened.
- g Check around the cab for loose or missing bolts, screws etc. Replace or tighten where necessary.
- h Check the excavator lever gaiters are not damaged or loose, replace or secure as required with new fasteners.

- i Inspect the seat belt and its mountings for damage and excessive wear.

- 5 Fasten the seat belt. See **Seat Belt**.

### **WARNING**

**When a seat belt is fitted to your machine replace it with a new one if it is damaged, if the fabric is worn, or if the machine has been in an accident. Fit a new seat belt every three years.**

2-3-1-7\_1

- j Check that the following are in working order:

Lights, Horn, All Switches, Windscreen Washer and Wipers (if fitted).

- 3 Adjust the seat so that you can comfortably reach all the driving controls. You should be able to operate the control pedal with your back against the seat back. Ensure the seat locking lever has fully engaged.
- 4 Set the throttle control to idle.



## Starting the Engine

### **WARNING**

**Do not use ether or other starting fluids to assist cold starting. Using these fluids may result in an explosion causing possible injury and/or damage to the engine.**

3-2-1-9

- 1 Read and comply with ***Before Starting the Engine.***
- 2 If the machine has an immobiliser then you must disarm the immobiliser before you can start the engine. Refer to ***Immobiliser (if fitted).***
- 3 Start the Engine
  - a Move the throttle lever to half speed position.
  - b Turn the starter key to the glow plug position **II** for approximately 6 seconds to warm the engine combustion chambers.

**Note:** Outside temperatures below 0°C (32°F) will require extended times.

- c Turn the starter key further to position **III** and hold it there until the engine starts; Do not operate the starter for more than 15 seconds at one time.

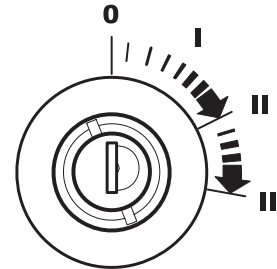

**Fig 49.**

H04432-2



### Starting the Engine

- If the engine does not start, return to the **0** (OFF). Allow the starter to cool for a few minutes before repeating step 3.

#### CAUTION

If the oil pressure low light does not go out within 15 seconds of the engine starting, stop the engine immediately to avoid engine damage. Do not start the engine until the fault has been rectified.

0200

- Once the engine has started, check that all the warning lights have gone off. Do not race the engine until the oil pressure warning light has gone out. Refer to **Warning Lights**.

If any warning lights fail to go off, or come on while the engine is running, stop the engine as soon as it is safe to do so.

**Note:** The engine noise and or tone may be louder than usual when cold. The engine will become quieter when the engine reaches normal operating temperature.

#### WARNING

Thoroughly warm the hydraulic oil before operating the excavator services. Before selecting boom up, check there are no overhead obstructions or electric power cables.

HOP40

- Warm up the Engine and Hydraulics.

Allow the engine to warm up at idle speed for five minutes. Operate the excavator a few times to help warm up the hydraulic system.

**Note:** Outside temperatures below  $-15^{\circ}\text{C}$  ( $5^{\circ}\text{F}$ ) require an extended warm up procedure. Refer to **Warming Up**.

Do not operate attachments until the hydraulic oil has reached its normal operating temperature.



## Warming Up

P11-2032

Before starting work in temperatures below  $-15^{\circ}\text{C}$  ( $5^{\circ}\text{F}$ ), hydraulic fluid must be warmed.

### 1 Warm up the engine:

After starting the engine set the throttle lever to mid position and run for 10 minutes.

**Note:** Do not operate any services. After the warm up period make sure that everyone is clear of the machine.

### 2 Warm up the hydraulic oil:

- a Increase engine speed to maximum. Warm the hydraulic oil by repeatedly selecting bucket crowd by moving the right hand lever to the left for 5 seconds. Repeat for several minutes.
- b Select dozer up by moving dozer control lever backwards, keep selected for one minute.

### 3 Warm up hydraulic circuit:

- a Reduce engine speed by moving throttle lever to mid position.
- b Raise and lower boom from ground level to full height five times.
- c Stroke the dipper fully in both directions, five times.
- d Rotate the bucket fully in both directions, five times.
- e Slew the upper structure clockwise for one revolution and stop. Slew the upper structure anticlockwise for one revolution and stop.
- f Repeat 3c three times.

### 4 The machine should now operate correctly. Should operation still appear slow, then steps 3b and 3c may be repeated.



### Starting the Engine

## Immobiliser

There are two different JCB immobiliser systems, one uses a keypad and the other a unique key system.

**Note:** *If your machine has an immobiliser system installed, then your JCB dealer should enable the system as part of the standard machine installation.*

## Keypad Immobiliser System

### To Disarm the Immobiliser

T2-028\_5

**Note:** *You have three attempts to disarm the system, the fourth attempt will lock the system for 30 minutes. It then resets and you will have three more attempts.*

**Note:** *If you wait more than eight seconds between button presses, then the immobiliser will go into error mode.*

1 Put the starter key in the starter switch.

2 Push the **MD** button, then enter your four-digit PIN number. The LED **A** flashes when you push a button.

3 Push the **ENT** button.

The LED **A** flashes twice when you enter an incorrect PIN number. You must complete step 2 again.

The LED **A** comes ON for three seconds after you enter a correct PIN number. Continue to step 4.

4 Start the engine as shown in **Starting the Engine**.

### Starting the Engine

**Note:** If you restart start the engine within 2 minutes, the system disarms automatically.

#### To Add a New or Additional PIN Code

The Keypad Immobiliser System can be programmed to accept a maximum of 14 different four-digit PIN codes.

- 1 Turn the starter switch to position I.
- 2 Push the **MD** button.
- 3 Enter the six-digit master code then push the **ENT** button. The LED **A** will flash 3 times.
- 4 Within 59 seconds, push the **MD** button.
- 5 Enter the new or additional PIN code.
- 6 Push the **ENT** button. The LED **A** will flash 4 times.

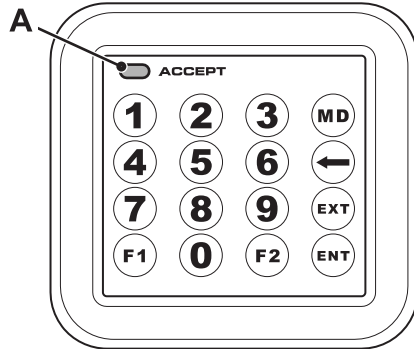

Fig 50.

T023290-2

#### To Arm the Immobiliser

- 1 Stop the engine and remove the starter key.

The immobiliser arms automatically after 2 minutes. The red LED **A** flashes for 60 seconds then goes OFF.

#### To Delete All PIN Codes

- 1 Turn the starter switch to position I.
- 2 Push the **MD** button.
- 3 Enter the six-digit master code, the LED **A** will flash 3 times.
- 4 Push the buttons in the sequence shown: **ENT**, **MD**, **F1** then **ENT**. If you have successfully deleted all the PIN codes, the LED **A** will flash 5 times.

#### 'Unique Key' Immobiliser System

T2-029\_4

Each machine is supplied with a master key (red) and two starter keys (black). The master key is used by the operator to program the starter keys. You must use a starter key to start or operate the machine.

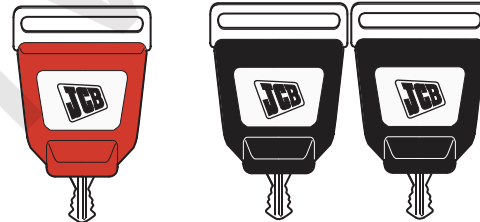

Fig 51.

T050110-1

#### To Disarm the Immobiliser

- 1 Put the starter key in the starter switch.

- 2 Start the engine as shown in **Starting the Engine**.

When the engine starts, the red LED **B** comes ON for three seconds then goes OFF.

**Note:** The position of the red LED **B** can change depending on the machine type.

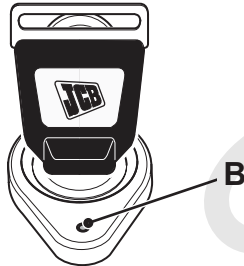

Fig 52.

T023301-1

#### To Arm the Immobiliser

- 1 Stop the engine and remove the starter key.

The immobiliser arms automatically immediately. The red LED **B** flashes for 60 seconds then goes OFF.

#### To Add a New or Additional Starter key

**Note:** Starter keys can be programmed to start more than one machine.

- 1 Put the master key in the starter switch then turn the starter switch to position I. The LED will flash 3 times.
- 2 Turn the starter switch to position 0 then remove the master key.
- 3 Put a new or an additional starter key in the starter switch then turn the starter switch to position I. The LED will flash 4 times to confirm the starter key has been added.



#### To Remove the Program from a Starter Key

- 1 Put the master key in the starter switch then turn the starter switch to position I. The LED will flash 3 times.
- 2 Keep the starter switch in position I for 60 seconds, the LED will flash 5 times.

The starter key codes have now been deleted from the ECU.

- 3 Turn the starter switch to position 0 then remove the starter key.

**Important:** *The starter keys will still be able to be used on any other machine on which they have been programmed.*



## Stopping and Parking the Machine

### **WARNING**

Low speed must always be selected when unloading the machine from a vehicle or tracking down steep slopes. The machine will take longer to stop when the levers are released if high speed is selected.

0076

Whenever possible, stop the machine on dry and level ground.

- 1 If possible, stop the machine on dry and level ground.

Release the two track levers **A** then push the hand throttle lever **B** to the idle position.

### **WARNING**

Ensure that the excavator is in a safe condition.

8-2-9-34

### **CAUTION**

Before stopping the engine, lower the dozer blade to the ground.

8-2-9-27

- 2 Lower the bucket and dozer to the ground.
- 3 Stop the engine.
- 4 Release the hydraulic pressure. Refer to **Releasing the Hydraulic Pressure (Maintenance Section)**.
- 5 Switch off all unnecessary switches. If you are leaving the machine, make sure that all switches are set to off.
- 6 Leave and secure the machine. Raise the left armrest or engage the lever lock(s). Use the handrail to leave the cab. If you are leaving the machine for a long

## Stopping and Parking the Machine

period, close and latch the window and lock the door.  
Make sure that the fuel filler cap is locked.

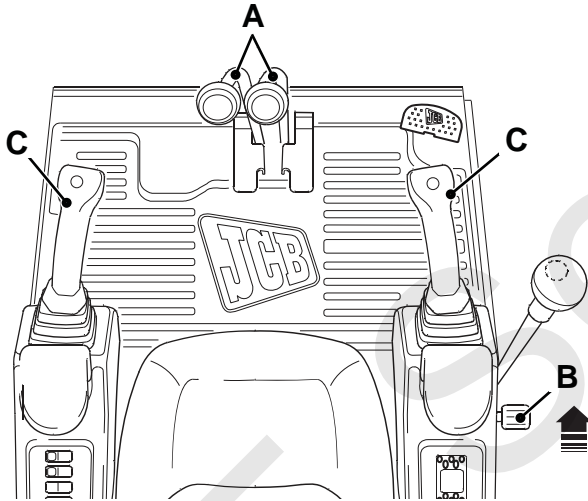

Fig 53.

## Preparing the Machine for Travel

### Introduction

When you travel on the road or on site there are usually local rules and safety regulations for the machine travel position. The ***Preparing for Site Travel*** described on the following pages are recommendations that should help you meet the requirements of these regulations; they are not necessarily the applied law.

Please make sure that before you travel on site, you and your machine comply with all the relevant local laws - it is your responsibility.

### Preparing for Site Travel

P11-2029\_2

- 1 Activate warning beacon if fitted.
- 2 Cab facing forward over dozer, dozer blade fully up.
- 3 Position the excavator:

Level Site Conditions: Position boom fully up, operate dipper fully in and bucket fully crowded, i.e. bucket rotated fully towards cab.

Uneven Site Conditions: Lower the boom so that the bucket or attachment is approximately 150 mm (6 in.) from the ground. → [Fig 54.](#) (□ 114)

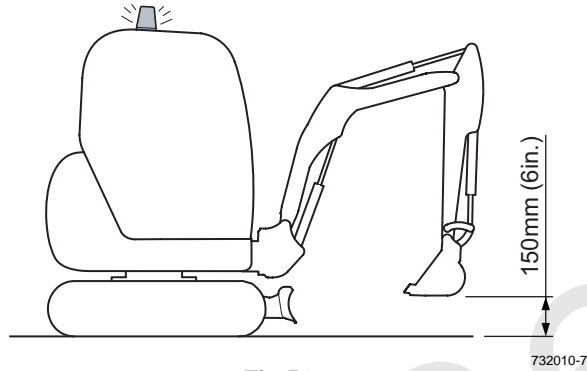

**Fig 54.**

## Working with the Machine

### Operating Practices and Site Safety

T2-057\_2

This section explains some techniques and procedures for efficient and safe use of the machine and its attachments. Attention is also drawn to the various safety aspects of operating on site.

Read and understand this section before you start working with the machine.

Make sure that you have had adequate training and that you are confident in your ability to operate the machine safely before you use it. Practice using the machine and its attachments until you are completely familiar with the controls and what they do.

With a careful, well trained and experienced operator, your machine is a safe and efficient machine. With an inexperienced or careless operator, it can be dangerous.

Do not put your life, or the lives of others, at risk by using the machine irresponsibly.

Before you start to work, tell your work mates what you will be doing and where you will be working. On a busy site, use a signalman.

Appropriate job site organisation is required in order to minimise hazards that are caused by restricted visibility. Job site organisation is a collection of rules and procedures that coordinates machines and people that work together in the same area. Examples of job site organisation include:

- Restricted areas
- Controlled patterns of machine movement
- A system of communication

You and/or your company could be legally liable for any damage you may cause to public utilities. It is your



### Working with the Machine

responsibility to make sure that you know the locations of any public utility cables or pipes on the site which could be damaged by your machine.

Before doing any job not covered in this manual, find out the correct procedure. Your local JCB distributor will be glad to advise you.

There are a wide variety of situations in which your machine may be used. Consequently, in all cases, the applicability of these notes must be determined by the person seeking to apply them, on the basis of his/her own judgement, in the light of the conditions in which use is intended and subject to all relevant statutory requirements.

The information in this section is given in good faith and in light of the best information available, JCB can accept no responsibility for the recommendations, advice, statements, opinions and conclusions expressly or by implication and gives no warranty or representation of assurance in respect of the accuracy of the same.

Remember that your machine is mobile. Whenever possible, manoeuvre it into a position which combines safety and efficiency. But if you have to choose, always remember that: Safety must come first.

## Clothing and Safety Equipment

T2-069

Do not wear loose clothing or jewellery that can get caught on controls or moving parts. Wear protective clothing and personal safety equipment issued or called for by the job conditions, local regulations or as specified by your employer.

## Danger Zone

T2-046

The danger zone is the circular area around the machine where the moving parts can reach. During operation of the machine, keep all persons out of the danger zone. Persons in the danger zone could be injured. Refer to **Specifications**.



## Log Moving/Handling

T2-047

Do not use the machine to move or handle logs unless it has been fitted with adequate log protection. You could cause serious injury to yourself and damage the machine. Contact your JCB dealer.

## Safety Practices

P2-2019\_3

Read *Operating Safety (Introduction Section)*, plus the following information.

### WARNING

#### Reworking Old Sites

There could be dangerous materials such as asbestos, poisonous chemicals or other harmful substances buried on the site. If you uncover any containers or you see any signs of toxic waste, stop the machine and advise the site manager immediately.

2-2-5-5

### WARNING

#### Water Supplies and Drains

Before you start using the machine, check with your local public water supplier if there are buried pipes and drains on the site. If there are, obtain a map of their locations and follow the advice given by the water supplier.

You are strongly advised to make sure that the safety arrangements on site comply with the local laws and regulations concerning work near buried pipes and drains.

2-2-5-6

### WARNING

#### Fibre Optic Cables

If you cut through a fibre optic cable, Do not look into the end of it, your eyes could be permanently damaged.

8-2-9-20

#### **WARNING**

##### **Underground Gas Pipes**

Before you start using the machine, check with your local gas company if there are any buried gas pipes on the site.

If there are buried gas pipes we recommend that you ask the gas company for any specific advice regarding the way you should work on the site.

Some modern gas pipes cannot be detected by metal detectors, so it is essential that an accurate map of buried gas pipes is obtained before any excavation work commences.

Hand dig trial holes to obtain precise pipe locations. Any cast iron pipes found should be assumed to be gas pipes until contrary evidence is obtained.

Older gas pipes can be damaged by heavy vehicles driving over the ground above them.

Leaking gas is highly explosive.

If a gas leak is suspected, contact the local gas company immediately and warn all personnel on the site. Ban smoking, ensure that all naked lights are extinguished and switch off any engines which may be running.

You are strongly advised to make sure that the safety arrangements on site comply with the local laws and regulations concerning work near buried gas pipes.

2-2-6-1\_1



### Working with the Excavator

#### Introduction

P2-2020

Before you start using the excavator, you must convert the machine into a safe and stable working platform. Refer to ***Preparing to use the Excavator (Operation Section)***.

To use the excavator efficiently and safely you must know the machine and have the skill to use it. This manual instructs you on the machine, its controls and its safe operation. It is not a training manual on the art of excavating. If you are a new operator, get yourself trained in the skills of using the excavator before trying to work with it. If you don't, you will not do your job well, and you will be a danger to yourself and others.

If you will be working with a labourer, make sure you both understand what each other will be doing. Learn and use the recognised signalling procedures. Do not rely on shouting - he will not hear you.

#### Working with the Machine

Make sure the correct bucket for the job is fitted. For instructions for removing and installing buckets, refer to ***Optional Attachments***.

#### **WARNING**

**When using the boom and dipper fully extended, take the following precautions, otherwise the machine could get damaged or become unstable and a danger to you and other people.**

**Make sure you do not exceed the working capacity of the boom at maximum reach. Swing the boom slowly to prevent any chance of the machine becoming unstable. For the same reason avoid dumping downhill if possible.**

8-2-9-28



#### **WARNING**

**Care must be taken with machines fitted with an extra long dipper as it may affect the stability of the machine.**

8-2-9-30

#### **Preparing to Use the Excavator**

P11-2031

When choosing a digging position, avoid digging downhill if possible. Whenever possible, dump the load on the uphill side of the excavation. Both these precautions will help to keep the machine stable.

When the machine is in the desired position on the site, lower the dozer to the ground.

## Digging

### Introduction

P11-2027

### WARNING

When you are excavating Do not rest your feet on the foot pedals. Even light pressure on the pedals can cause the brakes to be released.

8-2-2-5

### CAUTION

When carrying out deep digging with the superstructure swung to any position other than in line with the undercarriage, it is possible that part of the boom structure may contact the machine. Take extra care when digging, to avoid damaging the machine.

8-2-9-4

### CAUTION

Do not excavate on hard or rocky ground with the boom positioned diagonally across the undercarriage. The resulting rocking motion could cause damage to the track gearbox sprockets and tracks.

8-2-2-6\_2

It is possible when excavating, to use either full machine slew when discharging a loaded bucket, or if conditions dictate, swinging the excavator end only to the required dumping area.

- 1 To start the dig, reach out with the boom and dipper and position the bucket.

Slowly close the bucket at the same time bring the dipper in. Make sure the bucket stays at the same angle to the ground while it travels. If necessary, at the same time apply a downward pressure on the boom, to increase the digging force on the bucket.



### Working with the Machine

- When the bucket is full, close it fully and at the same time move the dipper out a little way. This will keep soil from building up under the machine.

### CAUTION

**Do not use the side of the excavation to stop the bucket when swinging back into position for the next dig. Similarly, do not use the side of the bucket to push soil into the excavation. Both these practices will damage the machine.**

16-2-7-2

- Slew the machine or swing the bucket to the dump area.

Start dumping as the bucket approaches the pile. Do not waste time by dumping too far from the excavation. Dump close to the start dig position.

Swing the bucket back to the excavation and start the next dig.

Backfill the excavation by loading the bucket with soil from the pile. Do not push the soil with the side of the bucket.

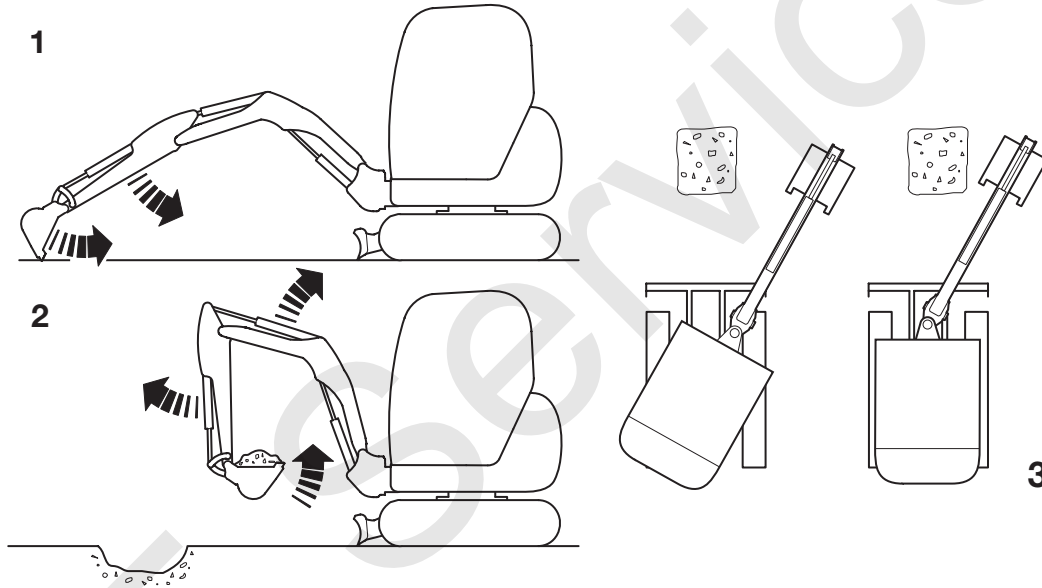

Fig 55.

731990-2

## Working with the Machine

### Moving the Machine While Digging on the Level

P11-2028

When digging a trench or hole which is longer than the excavator's reach, dig to the required depth and width **A** until it is not possible to dig any closer without contacting the machine.

When this position is reached, move the machine a suitable distance away from the excavation.

Lower the dozer blade until the machine is level, then continue digging **B**.

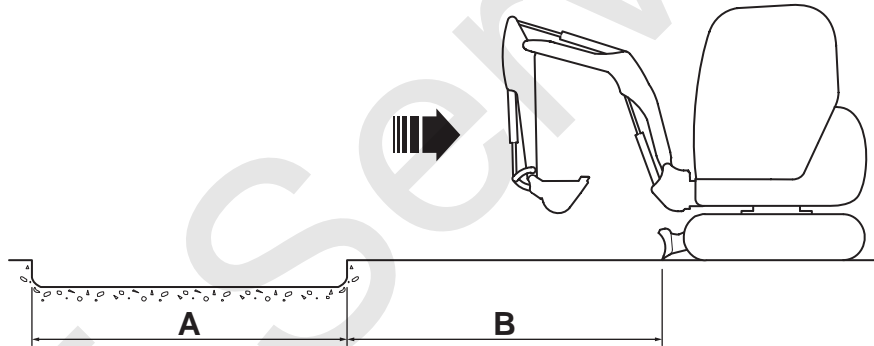

Fig 56.

733230-3



## Lifting (Object Handling)

### Introduction

#### **WARNING**

Do not use the machine for object handling unless it is equipped for this purpose. Without the relevant devices the machine can become unstable and tip over. You and others could be seriously injured or killed

8-2-8-19\_2

#### **WARNING**

Before you lift a load with the excavator, you must read and understand this section. Failure to take the precautions shown can result in death or injury.

2-2-7-38

Before using this machine for lifting, refer to *Specifications, Lifting (Object Handling) Regulations and Safe Working Loads.*

If your machine is not fitted with a lifting point such as hook or shackle, hose burst check valves, load charts and a overload warning system then it must not be used for object handling. If your machine is not fitted with this equipment you must use the machine for earthmoving purposes only.

### Lifting With the Excavator

#### WARNING

You must turn on the overload warning system before you use the excavator for object handling, or a stability hazard could occur.

8-2-8-20

Lifting operations must be carried out with the overload warning system turned ON, ⇒ [Overload Warning System \(If fitted\) \(p 96\)](#).

**Note:** Use a signalman when lifting with the excavator. Make sure you both understand and use the recognized signals. Keep all persons clear of the load and machine while the load is on the excavator.

- 1 A bucket should be fitted when lifting with the excavator to prevent the link swinging. Check that the load is not greater than the safe working load for the bucket.

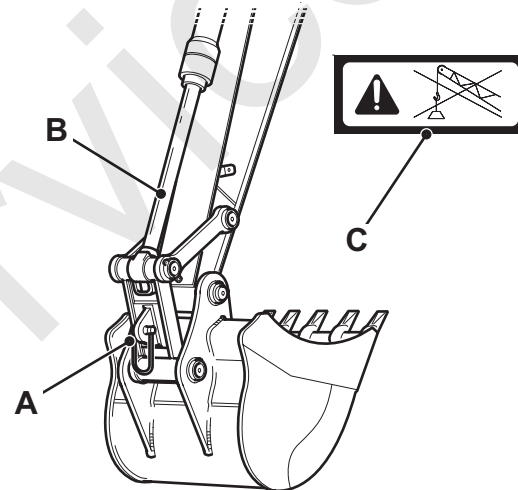

Fig 57.

T033970-2

- 2 The correct JCB lifting shackle **A** must be fitted. The bucket ram must be fully extended as at **B**. If your machine is not fitted with this equipment there will be



a decal **C** in the operators cab and you must use the machine for earth moving purposes only.

**Note:** *The lifting shackle must be removed when excavating to prevent the possibility of damage.*

- 3 Attach lifting chains to the shackle. Keep the chain length as short as possible, to prevent swinging.

**Important:** *Always use lifting tackle which is strong enough and in good condition. Check the load weight before choosing the lifting chains.*

- 4 Attach a handline to the load. Make sure the person holding the handline stands clear of the load and machine.
- 5 Test the load by lifting it 25-50 mm (one or two inches) and slowly manoeuvring it across the ground with the excavator controls. Lower the load to the ground if you feel any instability of the load or the machine.

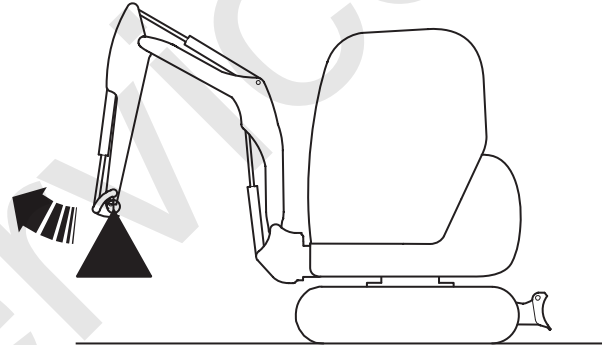

**Fig 58.**

T033971-1

When you are using the dipper movement to lift, always lift by moving the dipper away from you, as shown, not towards you. This is because hose burst protection valves (if fitted) are provided only on the 'dipper-in' side,

## Load Charts

### Introduction

The Safe Working Load (SWL) of the machine depends on how far the boom is extended and the angle it is raised to.  
⇒ [Safe Working Loads \(□ 285\)](#).

Lifting operations must be carried out using the load charts in the cab. The load charts refer to lift capacities relevant to the machine specification when equipped with an approved JCB tipping link, shackle and bucket ram. Weights of buckets, slings and auxiliary devices must be deducted from these capacities. Care must be taken to ensure that these loads are not exceeded.

**Important:** *If a load chart is not provided in the cab the machine is not designed for lifting.*

## CAUTION

The Load Chart shown is only an example. Do not use it to find the loading limits on your machine. Before lifting or placing loads, refer to the Load Charts in the cab of your machine.

5-2-4-2

The load chart is only fitted to machines with object handling equipment, it is located on the right hand window. The chart shows how far you can raise and extend a load without exceeding the safe working load. Each machine model has its own specific load chart.

The relevant load chart for your machine contains a part number. If the chart is missing or damaged a new decal must be fitted, contact your JCB dealer for advise if you are not sure. ⇒ [Load Charts \(□ 286\)](#).



**Using the Load Chart**

- A Working Height at Bucket Pivot

---

- B Distance of Bucket pivot from centre of machine (metres)

---

- C Weight to be lifted (kgs)

---

- D Safe Working Load

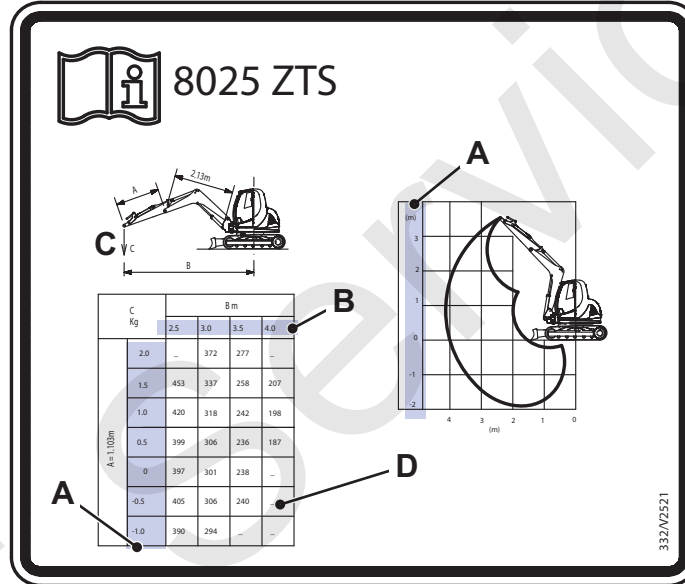

Fig 59. Example only

T052950-1

### Use of Machines on Gradients or Slopes

P11-2011

#### **WARNING**

Ensure that you have been trained and are familiar with the use of machines on gradients, and understand the adverse affects that gradients and site conditions can have on stability. Never use the machine on a gradient if you do not understand the recommended practices for the use of machines in such applications.

0017

There are a number of factors which can adversely affect the stability of the machine and the safety of the machine and operator when used on a gradient.

It is essential that a risk assessment of the work to be done is completed and that the operator complies with any safety precautions that the assessment identifies.

### Travelling on Slopes

The machine can operate without detriment to its systems on inclines of up to 25°. However, on slopes greater than 10° the operator must use his discretion and proceed with extreme caution.

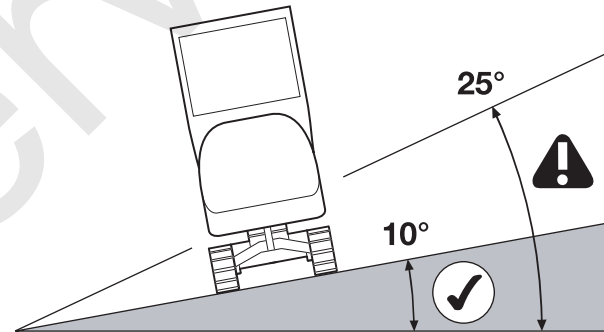
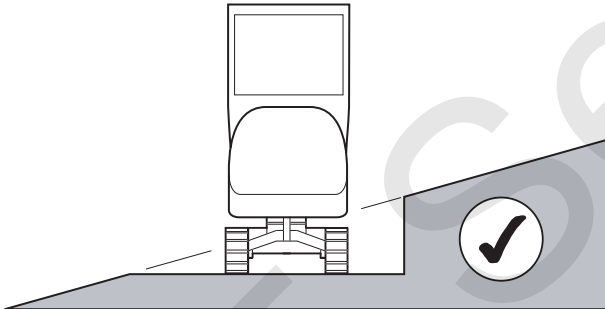

Fig 60.

732230-3

**Working on Slopes**

When working on inclines, position the dozer for maximum stability. This may mean the dozer and the boom are at the same end of the machine, especially if digging down hill, lower the dozer sufficiently to bring the machine level. If necessary, to prevent an instability problem, cut a level platform for the machine to stand on.

**Fig 61.**

732230-4

### Working with the Dozer

#### Introduction

P11-2026

Remember that you will be driving the machine while you are using the dozer. Keep alert for bystanders, animals and possible hazards.

Ensure the slew lock is engaged when working with the dozer.

#### Dozing and Grading

Keep the bottom of the dozer parallel to the ground. When grading a site remove high spots first, then use this soil to fill in troughs. Do not use excessive downward pressure on the dozer or machine traction could be lost. When working with the dozer, set the excavator straight with the machine, as for road travel. Keep the dozer high when travelling as this increases the machines ground clearance.

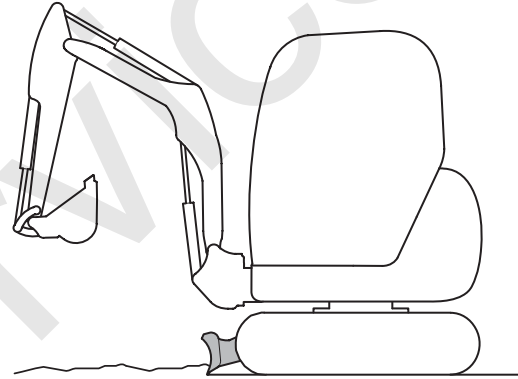

Fig 62.

732010-5

#### Scraping and Cutting

If a deep cut is to be made, do it in steps of about 50mm (2in). Do not forget to adjust the dozer height when the machine's tracks enter the cut.

#### Backfilling

When backfilling on a slope, pile the material on the high side of the trench whenever possible. Set the dozer level to the ground. Work at right angles to the trench filling a dozer's width at a time. Leave any spillage until the trench is filled. Use the spillage to finish the job by driving the length of the trench with the dozer low to the ground.

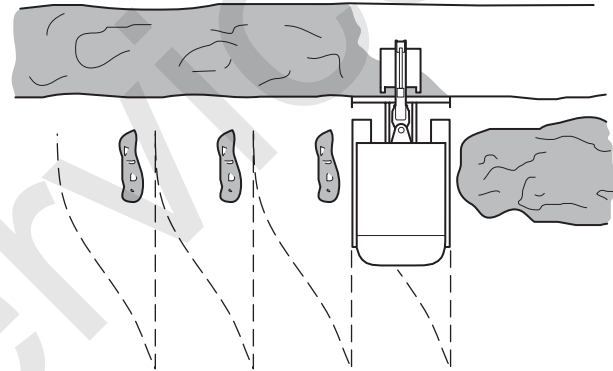

Fig 63.

732030-2



## Operating Environment

### Operating in Low Temperatures

T3-069\_2

In low temperature situations, take the following precautions. They will make for easier starting and prevent possible damage to your machine.

- 1 Use the correct viscosity engine lubricating oil.
- 2 If available use a low temperature diesel fuel.
- 3 Use the correct coolant mixture.
- 4 Keep the battery at full charge.
- 5 Fill the fuel tank at the end of each work period. This will help to prevent condensation forming on the tank walls.
- 6 Protect the machine when not in use. Park the machine inside a building or cover it with a tarpaulin.
- 7 Install a cold weather starting aid. In very low temperatures,  $-18^{\circ}\text{C}$  ( $0^{\circ}\text{F}$ ) and below, additional starting aids may be needed. Examples are fuel, oil and coolant heaters. Ask your JCB distributor for advice.  
**Important:** *Do not connect two batteries in series to give 24 volts for starting as this can cause damage to the electrical circuits.*
- 8 Remove snow from the engine compartment before starting otherwise snow could get into the air filter.

### Operating in a Cold Climate (Below 0°C)

In extremely low temperatures special care should be taken. Extend the warm up time and cover the front faces of the radiator and oil cooler, after warm up remove the covers.

- 1 Until the machine is thoroughly warmed up never attempt to slew rapidly or operate the travel system, otherwise damage may result.
- 2 Before operating the machine after warm-up, ensure that the boom, dipper bucket, slew and travel services all operate correctly. A time lag may occur when selecting these services if the hydraulic oil is not sufficiently warm.
- 3 If the machine is left outside for more than one day without usage, remove the battery and take it indoors.
- 4 Drain the water collected in the fuel system to prevent it freezing.

- 5 Clean the machine after use and place it on wooden blocks. Keep rams as fully retracted as possible. Wipe off any water from the exposed portion of the piston rods.
- 6 Additional low temperature fuel and lubricants and batteries may be required. Consult your local JCB dealer for advice.

### Operating in High Temperatures

T3-070

In high temperature situations, take the following precautions to prevent possible damage to the machine.

- 1 Use the correct viscosity engine lubricating oil.
- 2 Use the correct coolant mixture.
- 3 Check the coolant system regularly, keep the coolant at the correct level. Make sure there are no leaks.



- 4 Keep the radiator/oil cooler clean, regularly remove dirt and debris from the radiator/oil cooler and the engine.
- 5 Check the fan belt regularly.
- 6 Check the air vents. Make sure that the air vents to and from the engine compartment are not blocked.
- 7 Check the engine pre-cleaner regularly (if fitted).
- 8 Check the battery electrolyte level.

### Operating in Dusty or Sandy Areas

- 1 Air Cleaner. Frequently check, clean or replace the elements regardless of the inspection interval. (Not the safety element).
- 2 Securely tighten the hydraulic oil tank filler cap to prevent sand and dust from entering the hydraulic system.

### Operating in Coastal Regions

- 1 Check that all the plugs, bolts and fasteners are all tightened properly.
- 2 After daily operations, wash the machine thoroughly and take special care when cleaning the electrical devices and hydraulic cylinders to prevent salt entry and eventual corrosion.

### Operating on Wet or Soft Ground

- 1 Clean the Machine.

Moisture or mud will cause the paint, wiring and metallic parts to deteriorate. When operating the machine keep it as dry as possible and regularly grease the machine.



## Getting the Machine Moving

### Operating Practices

The machine does not have gears. Do not overwork the engine unnecessarily. Operate at an engine speed suitable for the duty being carried out.

**Note:** *Too low an engine speed may result in lack of dipper control.*

When moving the machine, keep it under control at all times. Stay alert for obstructions and possible hazards. Approach deep mud slowly.

### WARNING

**Do not dismount a moving machine.**

3-2-3-12

Take particular care when reversing. Ensure that the way behind is clear before reversing.

### WARNING

**Should the machine start to roll over, you can be crushed if you try to leave the cab. If the machine starts to roll over, do not try and jump from the cab. Stay in the cab, with your seat belt fastened.**

INT-2-1-12



### Getting the Machine Moving

## Operating Procedure

After you have warmed up the engine, move off as described below.

**Note:** Control and switch locations are provided within this manual. Refer to **Cab Layout**.

- 1 Check your seat belt and seat.
    - a Make sure that your seat belt is correctly fastened.
    - b Make sure that the seat is correctly adjusted.
  - 2 Make sure that the cab slew lock is disengaged and the slew switch is pressed.
  - 3 Move off.
    - a Check that the attachments are in the travel position.
- b Take hold of both track control levers in one hand.
  - c Make sure that it is safe to move off.
  - d Move the levers forward or backward as required and pull the throttle lever slowly backward until the desired speed is attained.
  - e To increase tracking speed operate the two speed tracking switch.

## Refuelling the Machine

### Low Fuel Levels

If you operate the machine on very low fuel levels, then air can enter the fuel system. To prevent the entry of air, always add more fuel when the fuel gauge shows a low level of fuel.

If air enters the fuel system, the engine speed will vary dramatically and low power will be experienced. The symptoms may be made worse when the machine operates on steep gradients.

**Note:** *If you increase the engine speed or load while there is air in the fuel system, then subsequent damage to the engine can occur.*

If the fuel supply contains air, you must stop the engine, fill the fuel tank then bleed the fuel system to remove the air. Refer to **Routine Maintenance, Fuel System**.

**Important:** *You must bleed the fuel system after a fuel filter change.*

### Filling the Tank

**Important:** *Before you add the fuel to the machine, refer to **Fluids, Lubricants and Capacities, Fuels**. If you use the incorrect type of fuel or fuel which is contaminated, then damage to the fuel injection system can occur.*

### CAUTION

**Consult your fuel supplier or JCB distributor about the suitability of any fuel you are unsure of.**

GEN-9-2

---

#### **WARNING**

##### Fuel

Fuel is flammable; keep naked flames away from the fuel system. Stop the engine immediately if a fuel leak is suspected. Do not smoke while refuelling or working on the fuel system. Do not refuel with the engine running. Completely wipe off any spilt fuel which could cause a fire. There could be a fire and injury if you do not follow these precautions.

INT-3-2-2\_3

---

#### **WARNING**

##### Petrol

Do not use petrol in this machine. Do not mix petrol with the diesel fuel; in storage tanks the petrol will rise to the top and form flammable vapours.

INT-3-1-6

---

#### **WARNING**

##### Mobile Phones

Switch off your mobile phone before entering an area with a potentially explosive atmosphere. Sparks in such an area could cause an explosion or fire resulting in death or serious injury.

Switch off and do not use your mobile phone when refuelling the machine.

INT-3-3-9

---

#### **CAUTION**

Spilt fuel may cause skidding and therefore accidents. Clean any spilt fuel immediately.

Do not use fuel to clean the machine.

When filling with fuel, choose a well aired and ventilated area.

INT-2-2-12

At the end of every working day, fill the tank with the correct type of fuel. This will prevent overnight condensation from developing in the fuel.

**Note:** Do not fill the tank completely, leave some space to allow the fuel to expand.

- 1 Unlock and remove the fuel cap **A**.
- 2 Carefully fill with fuel.
- 3 Refit and lock the fuel cap, ensure that the vent is clear.

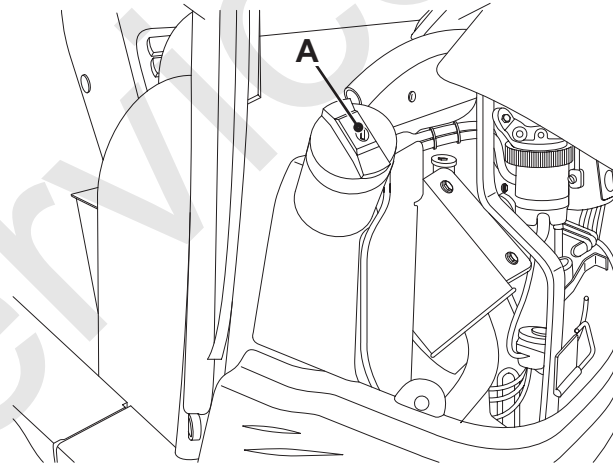

**Fig 64.**

772900-3



## Moving A Disabled Machine

### Introduction

The machine can be lifted onto a trailer for transportation. However, you must contact the nearest JCB Dealer before you try to tow, winch or push the machine. Towing, winching or pushing the machine without following the correct procedure will damage the hydraulic pumps. If possible, repair the disabled machine where it stands.

### Lowering the Boom in an Emergency

The excavator is fitted with an accumulator. The accumulator stores a limited amount of hydraulic pressure for use in an emergency (engine failure for example). This hydraulic pressure should be used to position the dipper and lower the boom into a safe position.

Do not attempt to operate other machine functions as this will deplete the hydraulic pressure in the accumulator and

it may then not be possible to position the dipper and lower the boom.

In the event of a emergency:

- 1 Turn the ignition to the 'ON' position.
- 2 Lower the control lock lever.
- 3 Use the right and left control levers to position the dipper and lower the boom, refer to ***Operating Levers (Operation Section)***.
- 4 Vent the hydraulics, refer to ***Releasing the Hydraulic Pressure (Maintenance Section)***.

### Retrieval

**Important:** It is not recommended to tow a disabled machine. Permanent damage to the track motors of the disabled machine may occur if the machine is towed.

If the machine becomes disabled, the machine should be made safe, lifted onto a transporter and moved to a location where it can be repaired. → [Lifting a Machine](#) (□ 154).

In the event that towing the machine to a safe location is unavoidable then attach wire rope or chain capable of pulling the machine to the lower frame as shown. → [Fig 65.](#) (□ 144).

**Important:** Do not use the tow eye or tie down points (if installed) to tow the machine, as this will cause damage to the machine.

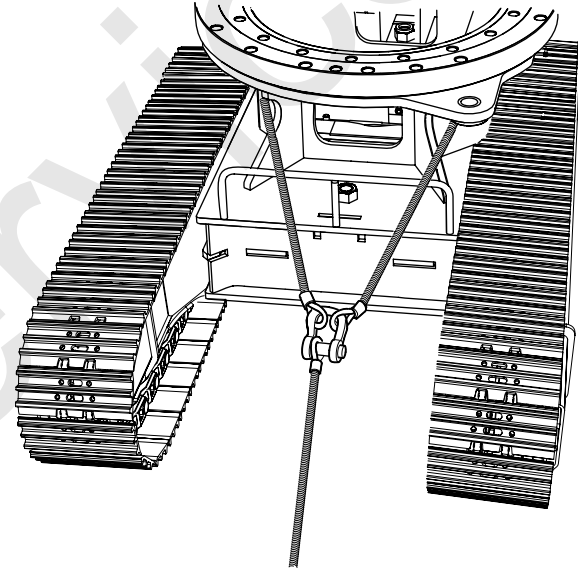

Fig 65.

T033230-5



Apply the minimum force to move the machine slowly (not greater than 2 kph (1.24 mph)) smoothly and without shocks.

Tow the machine the minimum distance to a safe location for recovery by lifting (not to exceed 20 m (65 ft)). Following this procedure the machine should be inspected by a qualified person for damage to the track motors.

## Transporting the Machine

P11-2003\_5

### Preparing for Road Travel

#### WARNING

**The safe transit of the load is the responsibility of the transport contractor and driver. Any machine, attachments or parts that may move during transit must be adequately secured.**

5-2-5-9

Before loading the machine on to its trailer remove all loose dirt that may otherwise come off and obstruct the highway and damage other vehicles.

**Note:** Before transporting the machine make sure you will be obeying the local rules and laws regarding machine transportation of all the areas that the machine will be carried through.

Make sure that the transporting vehicle is suitable. See **Maintenance** Section for the dimensions and weight of your machine. There is a travel height label fitted to the cab.

Try to make sure that the truck driver knows the clearance height before he drives away. See **Specification** Section for machine height figures.

**Note:** To calculate the clearance height  $X$ , add the overall height of the machine and the truck/trailer height together.

⇒ [Fig 67. \(□ 151\)](#).



#### Before Using the Trailer/Transporter

- 6 Check the breakaway cable is serviceable.

#### WARNING

**Before moving the machine onto the trailer, make sure that the trailer and ramp are free from oil, grease and ice. Remove oil, grease and ice from the machine tracks. Make sure the machine will not foul on the ramp angle.**

8-2-9-33

- 1 Remove any dirt or debris from the trailer.
- 2 Check the operation of the park brake.
- 3 Check the trailer bodywork for signs of damage.
- 4 Check the tyre pressures are correct (consult the Manufacturer's manual).
- 5 Check the lights are working and are the correct voltage for the towing vehicle (consult the Manufacturer's manual).



### Transporting the Machine

### Loading a Machine onto the Transporting Vehicle

- 1 Position the transporting vehicle on firm level ground.
- 2 Apply the park brakes and lower any stability jacks.

#### **WARNING**

**Make sure that the ramp incline does not exceed the machine's operational limits. See 'Working on Slopes' for further details.**

0133

- 3 Position the loading ramps securely on the transporter.
- 4 Align the machine with the loading ramps, position the dozer blade to the front and fully raised. Slightly extend the boom and dipper for stability. With the machine in low speed mode, track forward onto the ramp slowly and smoothly. Ensure the bucket will not

contact the transporter ramps when loading the machine.

- 5 Slowly drive the machine to the top of the ramps. Lower the boom until the bucket contacts the transporter deck. Slowly drive forward. As the tracks begin to clear the ramps, gently raise the boom allowing the machine to rock forward onto the transporter bed.
- 6 Slew the cab around 180°.
- 7 Machines fitted with mechanical slew lock, engage the slew lock.
- 8 Lower the bucket onto the transporter bed.
- 9 Stop the engine and secure the machine using the securing points on the vehicle. → [Securing the Machine \(150\)](#).
- 10 Remove and secure both ramps.

- 11 Raise any jacks to their transport position.

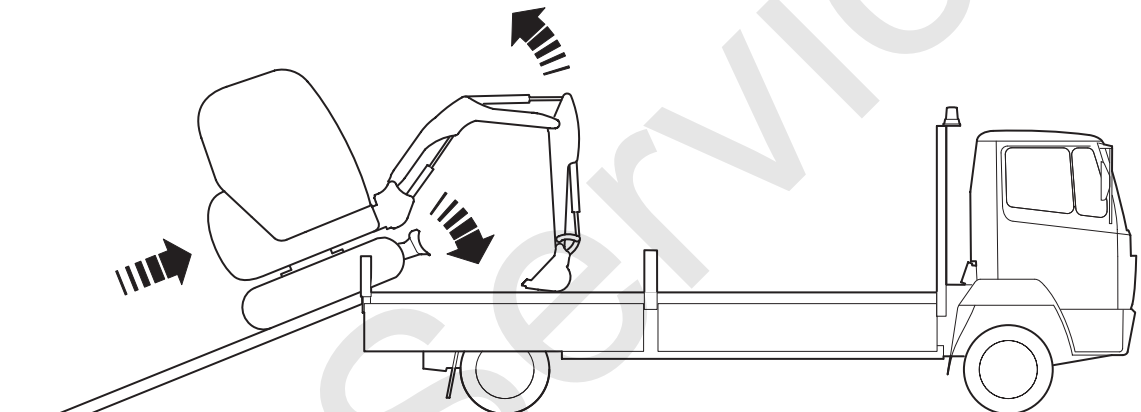

**Fig 66.**

800980-2

### Transporting the Machine

## Securing the Machine

### WARNING

**The machine must be securely tied down to the transport vehicle to prevent lateral movement, fore-and-aft movement, and slewing of the superstructure. Failure to do so could cause injury to yourself or others.**

0134

- 1 Machines fitted with mechanical slew lock, engage slew lock. Ensure by operating the slew control that the slew lock is engaged.
- 2 Close the bucket. Position the dipper vertically and lower the boom until the bucket rests on a wooden block on the trailer bed.
- 3 Position a securing strap **A** of suitable breaking strain over the bucket and secure to the trailer shackles.

- 4 Place skids **B** under each track at front and rear to prevent movement of the machine in the fore and aft direction.
- 5 Position a securing strap **C** of suitable breaking strain over the front and rear of the two track legs. Secure the securing straps to the trailer shackles to prevent lateral movement of the machine.
- 6 Attach securing straps **D** of suitable breaking strain to the kingpost and secure to the trailer shackles to prevent the superstructure from slewing.



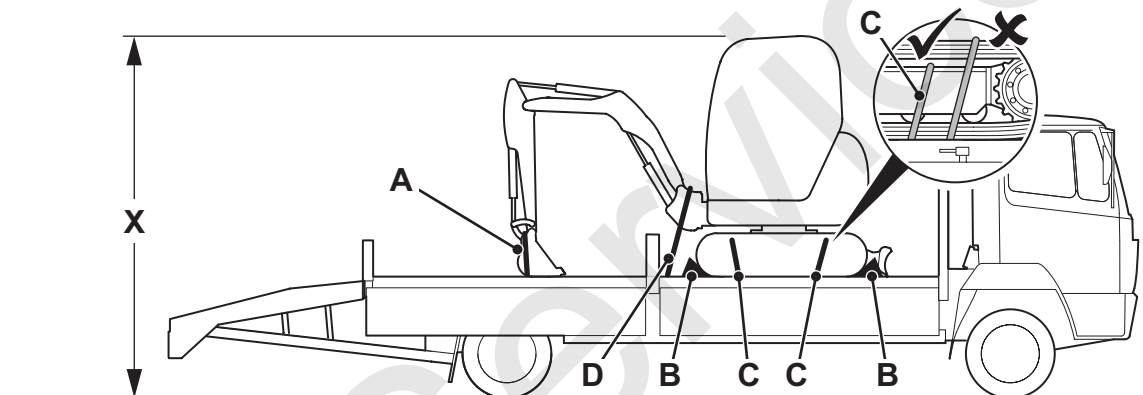

**Fig 67.**

800950-3

## Unloading a Machine from the Transporting Vehicle

- 1 Position the transporting vehicle on firm level ground.
- 2 Apply the park brakes and lower any stability jacks.

### WARNING

**Make sure that the ramp incline does not exceed the machine's operational limits. See 'Working on Slopes' for further details.**

0133

- 3 Position the loading ramps securely on the transporter.

**Note:** Ramps should be level with each other in the lowered position.

- 4 Remove the securing straps from the machine and stow them.

- 5 Start the machine and raise the bucket.

### WARNING

**If the dozer is to the rear, the track controls will be reversed. Use extreme caution when tracking off the trailer.**

0136

- 6 Raise the dozer. Track slowly to the ramps.
- 7 Lower the boom until the bucket contacts the ground. Continue to track forward until the tracks are over the lowered ramps. Carefully raise the boom, allowing the machine to rock onto the ramps.
- 8 Slowly drive off the transporter.

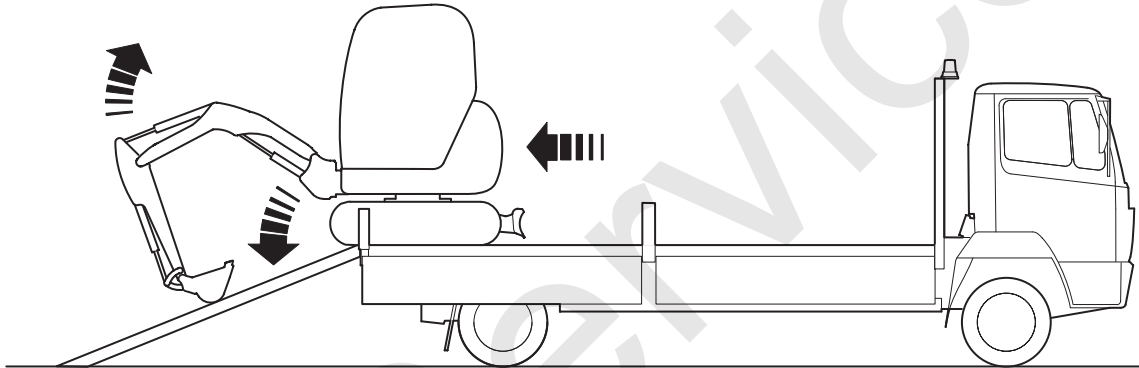

**Fig 68.**

800990-4

### Lifting a Machine

P11-2009

#### CAUTION

Do not lift the machine by the extended dozer (if fitted), remove the extensions before lifting. Ensure the lifting slings do not interfere with the top of the cab, damaging the top glazing. It may be necessary to remove the FOGS guard (if fitted).

8-2-9-24

Carry out the following procedure when lifting a machine:

- 1 Remove all attachments.
- 2 Remove all loose equipment from machine exterior.
- 3 Check the unladen weight of the machine. Refer to **Static Dimensions** (SPECIFICATIONS section).

#### WARNING

##### Lifting Equipment

You can be injured if you use faulty lifting equipment. Make sure that lifting equipment is in good condition. Make sure that lifting tackle complies with all local regulations and is suitable for the job. Make sure that lifting equipment is strong enough for the job.

INT-1-3-7

- 4 Attach lifting equipment to each end of the dozer blade at points **A**.
- 5 Attach lifting equipment to each side of the boom at points **B**.
- 6 Take the weight of the machine. Ensure the slings do not interfere with the cab. It may be necessary to use a spacer bar between the slings at **C**.

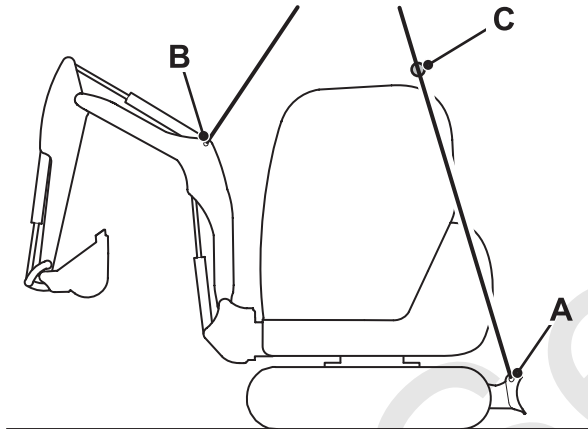

Fig 69.

732010-2

- 7 Check that the lifting eye is positioned directly above the machine centre of gravity.

### DANGER

Do not stand underneath the raised load during the lowering procedure. Stand clear and to one side until the load has been safely lowered. Make sure that the area is clear of other people before lowering the load. If you do not follow these precautions you or others could be killed or seriously injured.

2-3-5-3

### WARNING

#### Communications

Bad communications can cause accidents. Keep people around you informed of what you will be doing. If you will be working with other people, make sure any hand signals that may be used are understood by everybody. Work sites can be noisy, do not rely on spoken commands.

INT-2-2-3

## Storage of the Machine

### Introduction

If you will not use the machine for an extended period, you must store the machine correctly. If you prepare the machine carefully and apply on-going care you can prevent deterioration and damage to the machine while it is in storage.

T2-074

**Note:** JCB Dealers must check stock monthly.

### Storage Area

The machine can be stored in a temperature range of:

-40°C to 54°C (-40°F to 129°F).

When possible, you must keep the machine in a dry building or shelter.

If only an outdoor storage area is available, look for a storage area with good drainage.

If the machine is to be out of use for an extended period, careful preparation and on-going care will minimise the possibility of deterioration and damage while in storage.

### Prepare the Machine for Storage

T2-076

- 1 Clean the machine to remove all unwanted material and corrosive products.  
  
Dry the machine to remove solvents and moisture.
- 2 Apply grease to the moving parts. Refer to **Greasing the Machine**.
- 3 Examine the machine for worn or damaged parts. Replace if necessary.



### Storage of the Machine

- 4 Fill the fuel tank to prevent a build up of condensation in the tank.
- 5 Examine the coolant condition. Replace if necessary.
- 6 Examine all fluid levels. Top up if necessary.

### Put the Machine into Storage

- 1 Park the machine on level, solid ground.

Park the machine in a position where the machine is easy to get access (in case the machine does not start at the end of the storage period).

Place suitable timbers under the machine to eliminate direct contact with the ground.

- 2 Retract all rams and lower the attachments to the ground.
- 3 Vent the hydraulic system.

- 4 Remove the starter key.
- 5 Apply a thin layer of grease or petroleum jelly to all exposed ram piston rods.
- 6 Remove the battery. Charge the battery.

Keep the battery in warm, dry conditions. Charge the battery periodically.

- 7 If you keep the machine outdoors, cover the machine with tarpaulins or plastic sheets.

### During Storage

Operate the machine functions each week to prevent a build up of rust in the engine and hydraulic circuits, and to minimise deterioration of the hydraulic seals.



### Storage of the Machine

- 1 Clean the machine to remove all unwanted material and corrosives.

Remove the grease or petroleum jelly from the ram piston rods.

- 2 Install a charged battery.

- 3 Examine all fluid levels. Top up if necessary.

- 4 Start the engine.

- 5 Operate the hydraulic controls.

Make sure that the hydraulic functions operate correctly.

- 6 Prepare the machine for storage. Refer to ***Put the Machine into Storage.***

- 2 Examine all fluid levels. Top up if necessary.

- 3 Clean the machine to remove unwanted material and corrosives.

Remove the grease or petroleum jelly from the ram piston rods.

- 4 Install a charged battery.

- 5 Start the engine.

- 6 Operate the hydraulic controls.

Make sure that the hydraulic functions operate correctly.

### Take the Machine Out of Storage

T2-079

- 1 Examine the coolant condition. Replace If necessary



---

# Routine Maintenance

## Service Requirements

### Introduction

Your machine has been designed and built to give maximum performance, economy and ease of use under a wide variety of operating conditions. Prior to delivery, your machine was inspected both at the Factory and by your Distributor to ensure that it reaches you in optimum condition. To maintain this condition and ensure trouble free operation it is important that the routine services, as specified in this Manual, are carried out by an approved JCB Distributor at the recommended intervals.

T3-095

This section of the Manual gives full details of the service requirements necessary to maintain your JCB machine at peak efficiency.

A Service Manual for your machine is available from your JCB Distributor. The Service Manual contains information on how to repair, dismantle and assemble your machine correctly.

It can be seen from the Service Schedules on the following pages that many essential service checks should only be carried out by a JCB trained specialist. Only JCB Distributor Service Engineers have been trained by JCB to carry out such specialist tasks, and only JCB Distributor Service Engineers are equipped with the necessary special tools and test equipment to perform such tasks, thoroughly, safely, accurately and efficiently.

JCB regularly updates its Distributors advising them of any product developments, changes in specifications and



## Routine Maintenance

### Service Requirements

procedures. Therefore only a JCB Distributor is fully able to maintain and service your machine.

A Service Record Sheet or Book is provided which will enable you to plan your service requirements and keep a service history record. It should be dated, signed and stamped by your Distributor each time your machine is serviced.

Remember, if your machine has been correctly maintained, not only will it give you improved reliability but its resale value will be greatly enhanced.

### Owner/Operator Support

JCB together with your Distributor wants you to be completely satisfied with your new JCB machine. If you do encounter a problem however, you should contact your Distributor's Service Department who are there to help you!

You will have been given the names of the relevant service contacts at your Distributor when the machine was installed.

To get the most from your Distributor please help them to satisfy you by:

- 1 Giving your name, address and telephone number.
- 2 Quoting your machine model and serial number.
- 3 Date of purchase and hours of work.
- 4 Nature of the problem.

Remember, only your JCB Distributor has access to the vast resources available at JCB to help support you. In addition, your Distributor is able to offer a variety of programmes covering Warranty, Fixed Price Servicing, Safety Inspections, including weight tests, covering both legal and insurance requirements.



### Service/Maintenance Agreements

To help plan and spread the costs of maintaining your machine, we strongly recommend you take advantage of the many Service and Maintenance Agreements your Distributor can offer. These can be tailor made to meet your operating conditions, work schedule etc.

Please consult your JCB Distributor for details.

### Fit for Purpose Tests for Lifting Equipment

T3-097

All lifting equipment (for example forks, lifting hooks and shackles) need regular inspection and testing by a competent person to ensure they are fit for purpose.

This may be needed every six months or at least annually in some countries to meet and comply with legislation and for insurance purposes.

Check with your local JCB distributor for further advice.

### Obtaining Replacement Parts

T3-096

If you use non-genuine JCB parts or consumables, then you can compromise the health and safety of the operator and cause machine failure

A Parts Book for your machine is available from your JCB Distributor. The Parts Book will help you identify parts and order them from your JCB distributor.

Your dealer will need to know the exact model, build and serial number of your machine. See ***Identifying Your Machine (Introduction section)***.

The data plate also shows the serial numbers of the engine, transmission and axle(s), where applicable. But remember if any of these units have been changed, the serial number on the data plate may be wrong. Check on the unit itself.

## Health and Safety

### Lubricants

#### Introduction

It is most important that you read and understand this information and the publications referred to. Make sure all your colleagues who are concerned with lubricants read it too.

#### Hygiene

JCB lubricants are not a health risk when used properly for their intended purposes.

However, excessive or prolonged skin contact can remove the natural fats from your skin, causing dryness and irritation.

T3-060\_3

Low viscosity oils are more likely to do this, so take special care when handling used oils, which might be diluted with fuel contamination.

Whenever you are handling oil products you should maintain good standards of care and personal and plant hygiene. For details of these precautions we advise you to read the relevant publications issued by your local health authority, plus the following.

#### Storage

Always keep lubricants out of the reach of children.

Never store lubricants in open or unlabelled containers.

#### Waste Disposal

##### CAUTION

It is illegal to pollute drains, sewers or the ground. Clean up all spilt fluids and/or lubricants.

Used fluids and/or lubricants, filters and contaminated materials must be disposed of in accordance with local regulations. Use authorised waste disposal sites.

INT-3-2-14

All waste products should be disposed of in accordance with all the relevant regulations.

The collection and disposal of used oil should be in accordance with any local regulations. Never pour used engine oil into sewers, drains or on the ground.

#### Handling

##### WARNING

###### Oil

Oil is toxic. If you swallow any oil, do not induce vomiting, seek medical advice. Used engine oil contains harmful contaminants which can cause skin cancer. Do not handle used engine oil more than necessary. Always use barrier cream or wear gloves to prevent skin contact. Wash skin contaminated with oil thoroughly in warm soapy water. Do not use petrol, diesel fuel or paraffin to clean your skin.

INT-3-2-3

###### New Oil

There are no special precautions needed for the handling or use of new oil, beside the normal care and hygiene practices.



## Routine Maintenance

### Health and Safety

#### Used Oil

Used engine crankcase lubricants contain harmful contaminants.

Here are precautions to protect your health when handling used engine oil:

- 1 Avoid prolonged, excessive or repeated skin contact with used oil.
- 2 Apply a barrier cream to the skin before handling used oil. Note the following when removing engine oil from skin:
  - a Wash your skin thoroughly with soap and water.
  - b Using a nail brush will help.
  - c Use special hand cleansers to help clean dirty hands.

d Never use petrol, diesel fuel, or paraffin for washing.

- 3 Avoid skin contact with oil soaked clothing.
- 4 Don't keep oily rags in pockets.
- 5 Wash dirty clothing before re-use.
- 6 Throw away oil-soaked shoes.

#### First Aid - Oil

##### Eyes

In the case of eye contact, flush with water for 15 minutes. If irritation persists, get medical attention.

##### Swallowing

If oil is swallowed do not induce vomiting. Get medical advice.



#### Skin

In the case of excessive skin contact, wash with soap and water.

#### Spillage

Absorb with sand or a locally approved brand of absorbent granules. Scrape up and remove to a chemical disposal area.

#### Fires

### **WARNING**

**Do not use water to put out an oil fire. This will only spread it because oil floats on water.**

**Extinguish oil and lubricant fires with carbon dioxide, dry chemical or foam. Fire fighters should use self contained breathing apparatus.**

7-3-1-3\_1



### Battery

T3-061

#### **WARNING**

Batteries give off an explosive gas. Do not smoke when handling or working on the battery. Keep the battery away from sparks and flames.

Battery electrolyte contains sulphuric acid. It can burn you if it touches your skin or eyes. Wear goggles. Handle the battery carefully to prevent spillage. Keep metallic items (watches, rings, zips etc) away from the battery terminals. Such items could short the terminals and burn you.

Set all switches to OFF before disconnecting and connecting the battery. When disconnecting the battery, take off the earth (-) lead first.

Re-charge the battery away from the machine, in a well ventilated area. Switch the charging circuit off before connecting or disconnecting the battery. When you have installed the battery in the machine, wait five

minutes before connecting it up.

When reconnecting, fit the positive (+) lead first.

5-3-4-12

#### **CAUTION**

Do not disconnect the battery while the engine is running, otherwise the electrical circuits may be damaged.

INT-3-1-14

#### **WARNING**

##### Electrical Circuits

Understand the electrical circuit before connecting or disconnecting an electrical component. A wrong connection can cause injury and/or damage.

INT-3-1-4





## Routine Maintenance

Health and Safety

### DANGER

#### Electrolyte

Battery electrolyte is toxic and corrosive. Do not breathe the gases given off by the battery. Keep the electrolyte away from your clothes, skin, mouth and eyes. Wear safety glasses.

INT-3-2-1\_3

### CAUTION

Damaged or spent batteries and any residue from fires or spillage should be put in a closed acid proof receptacle and must be disposed of in accordance with local environmental waste regulations.

INT-3-1-12

### WARNING

#### Battery Gases

Batteries give off explosive gases. Keep flames and sparks away from the battery. Do not smoke close to the battery. Make sure there is good ventilation in closed areas where batteries are being used or charged. Do not check the battery charge by shorting the terminals with metal; use a hydrometer or voltmeter.

INT-3-1-8

### Warning Symbols

The following warning symbols may be found on the battery.

#### Symbol

#### Meaning



A289230-1

Keep away from children.



A289260-1

Shield eyes.



A289280

No smoking, no naked flames, no sparks.

#### Symbol

#### Meaning



A289250

Explosive Gas.



A289240

Battery acid.



A289270

Note operating instructions.



### First Aid - Electrolyte

Do the following if electrolyte:

#### **Gets into your eyes**

Immediately flush with water for 15 minutes, always get medical help.

#### **Is swallowed**

Do not induce vomiting. Drink large quantities of water or milk. Then drink milk of magnesia, beaten egg or vegetable oil. Get medical help.

#### **Gets onto your skin**

Flush with water, remove affected clothing. Cover burns with a sterile dressing then get medical help.

## Service Schedules

### Introduction

#### **WARNING**

T3-036\_3

**Maintenance must be done only by suitably qualified and competent persons.**

**Before doing any maintenance make sure the machine is safe, it should be correctly parked on level ground.**

**To prevent anyone starting the engine, remove the starter key. Disconnect the battery when you are not using electrical power. If you do not take these precautions you could be killed or injured.**

8-3-1-1

A badly maintained machine is a danger to the operator and the people working around him. Make sure that the regular maintenance and lubrication jobs listed in the

service schedules are done to keep the machine in a safe and efficient working condition.

Apart from the daily jobs, the schedules are based on machine running hours. Keep a regular check on the hourmeter readings to correctly gauge service intervals. When there is no hourmeter fitted, use the calendar equivalents to determine the service intervals. Refer to **Calendar Equivalents**. Do not use a machine which is due for a service. Make sure any defects found during the regular maintenance checks are rectified immediately.



# Routine Maintenance

## Service Schedules

### How to Use the Service Schedules

T3-012\_4

In the example shown, **A** shows all service requirements to be carried out every 10 hours and **B** shows the requirements to be carried out every 500 hours.

**Important:** Services should be carried out at either the hourly interval or calendar interval, whichever occurs first. Refer to **Calendar Equivalents**.

**Important:** The intervals given in the schedules must not be exceeded. If the machine is operated under severe conditions (high temperature, dust, water, etc.), shorten the intervals.

Pre-start Cold Checks, Service Points and Fluid Levels

Operation	10	50	100 <sup>(1)</sup>	500	1000	2000	8000
<b>ENGINE</b>							
Coolant Quality and Level - Check	<input type="checkbox"/>	<input type="checkbox"/>	<input type="checkbox"/>	<input type="checkbox"/>	<input type="checkbox"/>		
Cooling System - Drain and Refill						<input type="checkbox"/>	<input type="checkbox"/>
Oil level - Check	<input type="checkbox"/>	<input type="checkbox"/>					
Oil and Filter <sup>(2)(3)(4)</sup> - Change				<input type="checkbox"/>	<input type="checkbox"/>	<input type="checkbox"/>	<input type="checkbox"/>
Air Cleaner Dust Valve <sup>(5)</sup> - Change				<input type="checkbox"/>	<input type="checkbox"/>	<input type="checkbox"/>	<input type="checkbox"/>
Air Cleaner Outer Element <sup>(5)</sup> - Change					<input type="checkbox"/>	<input type="checkbox"/>	<input type="checkbox"/>
Air Cleaner Inner Element - Change						<input type="checkbox"/>	<input type="checkbox"/>
Pre-Cleaner (if fitted) - Check			<input type="checkbox"/>				
Water Separator - Check for contamination and Drain		<input type="checkbox"/>	<input type="checkbox"/>	<input type="checkbox"/>	<input type="checkbox"/>	<input type="checkbox"/>	<input type="checkbox"/>
Engine Fuel Filter - Change					<input type="checkbox"/>	<input type="checkbox"/>	<input type="checkbox"/>
Front End Accessory Drive (FEAD) Belt Condition - Check				<input type="checkbox"/>	<input type="checkbox"/>	<input type="checkbox"/>	<input type="checkbox"/>
Front End Accessory Drive (FEAD) Belt - Change							<input type="checkbox"/>
Engine Mounting Bolts for Tightness - Check			<input type="checkbox"/>	<input type="checkbox"/>	<input type="checkbox"/>	<input type="checkbox"/>	<input type="checkbox"/>
All Hoses - Condition - Check		<input type="checkbox"/>	<input type="checkbox"/>	<input type="checkbox"/>	<input type="checkbox"/>	<input type="checkbox"/>	<input type="checkbox"/>
Radiator <sup>(6)</sup> - Clean			<input type="checkbox"/>	<input type="checkbox"/>	<input type="checkbox"/>	<input type="checkbox"/>	<input type="checkbox"/>
Crankcase Ventilation Filter - Change					<input type="checkbox"/>	<input type="checkbox"/>	<input type="checkbox"/>

795390-1



## **Calendar Equivalents**

Every 10 Hours = Daily

Every 50 Hours = Weekly

Every 500 Hours = Six Months

Every 1000 Hours = Yearly

Every 2000 Hours = 2 Years

T3-098



## Routine Maintenance

Service Schedules

### Pre Start Cold Checks, Service Points and Fluid Levels

	Operation	10	50	500	1000	2000
<b>ENGINE</b>						
Oil level	- Check	<input type="checkbox"/>	<input type="checkbox"/>	<input type="checkbox"/>	<input type="checkbox"/>	<input type="checkbox"/>
Oil and Filter	- Change			<input type="checkbox"/>	<input type="checkbox"/>	<input type="checkbox"/>
Air Cleaner Element (Dusty Conditions only)	- Change			<input type="checkbox"/>	<input type="checkbox"/>	<input type="checkbox"/>
Air Cleaner Outer Element	- Change				<input type="checkbox"/>	<input type="checkbox"/>
Air Cleaner Inner Element	- Change					<input type="checkbox"/>
Air Cleaner Hose Security	- Check and Adjust		<input type="checkbox"/>	<input type="checkbox"/>	<input type="checkbox"/>	<input type="checkbox"/>
Air Filter Dust Valve	- Check and Clean			<input type="checkbox"/>	<input type="checkbox"/>	<input type="checkbox"/>
Fuel Injectors <sup>(1)</sup>	- Clean and Test					<input type="checkbox"/>
Coolant Quality/Level	- Check	<input type="checkbox"/>	<input type="checkbox"/>	<input type="checkbox"/>	<input type="checkbox"/>	<input type="checkbox"/>
Coolant	- Change					<input type="checkbox"/>
Fuel Lift Pump	- Clean			<input type="checkbox"/>	<input type="checkbox"/>	<input type="checkbox"/>



## Routine Maintenance

### Service Schedules

	<b>Operation</b>	<b>10</b>	<b>50</b>	<b>500</b>	<b>1000</b>	<b>2000</b>
Fuel Sedimenter	- Drain and Clean	<input type="checkbox"/>	<input type="checkbox"/>	<input type="checkbox"/>	<input type="checkbox"/>	<input type="checkbox"/>
Fuel Filter/Sedimenter Element	- Change			<input type="checkbox"/>	<input type="checkbox"/>	<input type="checkbox"/>
Primary Fuel Filter	- Check			<input type="checkbox"/>	<input type="checkbox"/>	<input type="checkbox"/>
Fuel Pre Filter	- Check			<input type="checkbox"/>	<input type="checkbox"/>	<input type="checkbox"/>
Fan Belt Tension/Condition	- Check and Adjust		<input type="checkbox"/>	<input type="checkbox"/>	<input type="checkbox"/>	<input type="checkbox"/>
Valve Clearances <sup>(1)</sup>	- Check and Adjust				<input type="checkbox"/>	<input type="checkbox"/>
Cylinder Head Bolts for Tightness	- Check and Adjust			<input type="checkbox"/>	<input type="checkbox"/>	<input type="checkbox"/>
Engine Mounting Bolts for Tightness	- Check and Adjust			<input type="checkbox"/>	<input type="checkbox"/>	<input type="checkbox"/>
Exhaust System Security	- Check and Adjust			<input type="checkbox"/>	<input type="checkbox"/>	<input type="checkbox"/>
Radiator	- Clean and Check	<input type="checkbox"/>	<input type="checkbox"/>	<input type="checkbox"/>	<input type="checkbox"/>	<input type="checkbox"/>
<b>TRANSMISSION</b>						
Security of Mounting Bolts and Nuts						
- Track Wheel Motor to Undercarriage Bolts	- Check			<input type="checkbox"/>	<input type="checkbox"/>	<input type="checkbox"/>





## Routine Maintenance

### Service Schedules

	Operation	10	50	500	1000	2000
- Drive Sprocket Bolts	- Check			<input type="checkbox"/>	<input type="checkbox"/>	<input type="checkbox"/>
- Slew Gearbox Bolts	- Check				<input type="checkbox"/>	<input type="checkbox"/>
Track Gearbox Oil	- Change			<input type="checkbox"/>	<input type="checkbox"/>	<input type="checkbox"/>
<b>HYDRAULICS</b>						
Oil Level	- Check	<input type="checkbox"/>	<input type="checkbox"/>	<input type="checkbox"/>	<input type="checkbox"/>	<input type="checkbox"/>
Oil	Change					<input type="checkbox"/>
Rams - Chrome Condition	- Check		<input type="checkbox"/>	<input type="checkbox"/>	<input type="checkbox"/>	<input type="checkbox"/>
Hoses and Pipework - Damage/Leaks	- Check		<input type="checkbox"/>	<input type="checkbox"/>	<input type="checkbox"/>	<input type="checkbox"/>
Return Filter Element	- Change			<input type="checkbox"/>	<input type="checkbox"/>	<input type="checkbox"/>
Suction Strainer	- Clean				<input type="checkbox"/>	<input type="checkbox"/>
Security of Mounting Bolts on Major Assemblies	- Check				<input type="checkbox"/>	<input type="checkbox"/>
<b>ELECTRICS</b>						
Battery Electrolyte Level (if applicable)	- Check			<input type="checkbox"/>	<input type="checkbox"/>	<input type="checkbox"/>



## Routine Maintenance

### Service Schedules

	Operation	10	50	500	1000	2000
Starter Motor and Alternator Brush Gear	- Check					<input type="checkbox"/>
Wiring for Chaffing/Routing	- Check		<input type="checkbox"/>	<input type="checkbox"/>	<input type="checkbox"/>	<input type="checkbox"/>
Battery Terminals for Condition and Tightness	- Check		<input type="checkbox"/>	<input type="checkbox"/>	<input type="checkbox"/>	<input type="checkbox"/>
<b>UNDERCARRIAGE</b>						
Track Rollers Bolts	- Check			<input type="checkbox"/>	<input type="checkbox"/>	<input type="checkbox"/>
Track Rollers Oil and Seals	- Change				<input type="checkbox"/>	<input type="checkbox"/>
Idler Wheels Oil and Seals	- Change				<input type="checkbox"/>	<input type="checkbox"/>
Track Plate Condition and Bolt Torque	- Check		<input type="checkbox"/>	<input type="checkbox"/>	<input type="checkbox"/>	<input type="checkbox"/>
Track Tension	- Check		<input type="checkbox"/>	<input type="checkbox"/>	<input type="checkbox"/>	<input type="checkbox"/>
<b>BODYWORK AND CAB</b>						
Cab Mounting Bolts Security	- Check and Adjust				<input type="checkbox"/>	<input type="checkbox"/>
All Pivot Pins	- Grease	<input type="checkbox"/>	<input type="checkbox"/>	<input type="checkbox"/>	<input type="checkbox"/>	<input type="checkbox"/>
Kingpost - kingpin retaining plate bolts torque	- Check			<input type="checkbox"/>	<input type="checkbox"/>	<input type="checkbox"/>



## Routine Maintenance

### Service Schedules

	Operation	10	50	500	1000	2000
Slew Ring Bearing	- Grease		<input type="checkbox"/>	<input type="checkbox"/>	<input type="checkbox"/>	<input type="checkbox"/>
Slew Ring Mounting Bolts	- Check				<input type="checkbox"/>	<input type="checkbox"/>
Slew Ring Pinion and Gear Teeth	- Grease				<input type="checkbox"/>	<input type="checkbox"/>
Door/Window Hinges	- Lubricate		<input type="checkbox"/>	<input type="checkbox"/>	<input type="checkbox"/>	<input type="checkbox"/>
Windscreen Washer Fluid Level	- Check	<input type="checkbox"/>	<input type="checkbox"/>	<input type="checkbox"/>	<input type="checkbox"/>	<input type="checkbox"/>
Machine Generally	- Check and Clean	<input type="checkbox"/>	<input type="checkbox"/>	<input type="checkbox"/>	<input type="checkbox"/>	<input type="checkbox"/>
<b>ATTACHMENTS</b>						
Quick Hitch	- Grease	<input type="checkbox"/>	<input type="checkbox"/>	<input type="checkbox"/>	<input type="checkbox"/>	<input type="checkbox"/>
<b>OPTIONAL EQUIPMENT</b>						
As Required	- Check	<input type="checkbox"/>	<input type="checkbox"/>	<input type="checkbox"/>	<input type="checkbox"/>	<input type="checkbox"/>

(1) Jobs which should only be done by a specialist.



## Routine Maintenance

Service Schedules

### Functional Test and Final Inspection

	Operation	10	50	500	1000	2000
<b>ENGINE</b>						
Idle and Maximum Speed <sup>(1)</sup>	- Check and Adjust			<input type="checkbox"/>	<input type="checkbox"/>	<input type="checkbox"/>
Exhaust Smoke (excessive)	- Check	<input type="checkbox"/>	<input type="checkbox"/>	<input type="checkbox"/>	<input type="checkbox"/>	<input type="checkbox"/>
Fuel System - Leaks and Contamination	- Check	<input type="checkbox"/>	<input type="checkbox"/>	<input type="checkbox"/>	<input type="checkbox"/>	<input type="checkbox"/>
<b>HYDRAULICS</b>						
Operation All Services - Excavator, Dozer etc.	- Check	<input type="checkbox"/>	<input type="checkbox"/>	<input type="checkbox"/>	<input type="checkbox"/>	<input type="checkbox"/>
Hoses and Pipework - Damage/Leaks	- Check		<input type="checkbox"/>	<input type="checkbox"/>	<input type="checkbox"/>	<input type="checkbox"/>
Main Relief Valve Pressure <sup>(1)</sup>	- Check and Adjust			<input type="checkbox"/>	<input type="checkbox"/>	<input type="checkbox"/>
Auxiliary Relief Valve Pressure <sup>(1)</sup>	- Check and Adjust			<input type="checkbox"/>	<input type="checkbox"/>	<input type="checkbox"/>
Slew Cross Line Relief Valve Pressure <sup>(1)</sup>	- Check and Adjust			<input type="checkbox"/>	<input type="checkbox"/>	<input type="checkbox"/>
Servo Relief Valve Pressure <sup>(1)</sup>	- Check and Adjust			<input type="checkbox"/>	<input type="checkbox"/>	<input type="checkbox"/>



## Routine Maintenance

Service Schedules

	Operation	10	50	500	1000	2000
<b>ELECTRICS</b>						
All Electrical Equipment Operation, (e.g. warning lights, beacon, alarms, horn, wipers etc.)	- Check	<input type="checkbox"/>	<input type="checkbox"/>	<input type="checkbox"/>	<input type="checkbox"/>	<input type="checkbox"/>
Hourmeter Operation	- Check	<input type="checkbox"/>	<input type="checkbox"/>	<input type="checkbox"/>	<input type="checkbox"/>	<input type="checkbox"/>
<b>UNDERCARRIAGE</b>						
Track and Running Gear Operation	- Check	<input type="checkbox"/>	<input type="checkbox"/>	<input type="checkbox"/>	<input type="checkbox"/>	<input type="checkbox"/>
<b>BODYWORK AND CAB</b>						
Excavator Lever and Swing Pedal Locks	- Check			<input type="checkbox"/>	<input type="checkbox"/>	<input type="checkbox"/>
<b>LIFTING EQUIPMENT</b>						
Fit for Purpose Test <sup>(2)</sup>	- Complete			<input type="checkbox"/>	<input type="checkbox"/>	<input type="checkbox"/>

(1) Jobs which should only be done by a specialist.

(2) This may be required every six months or at least annually in some countries to meet and comply with legislation and for insurance purposes.



## Fluids, Lubricants and Capacities

Table 1.

Item	Capacity Litres (UK Gal)	Fluid / Lubricant	International Specification
Fuel Tank	36.5 (8)	Diesel Oil	
Engine (Oil)	4.5 (1)	JCB Extreme performance 15W/40 above -15°C (above 5°F)	ACEA E5:B3:A3,API CH4/SJ
		5W/20 -15°C to -25°C (5°F to 13°F)	API CC/SE (recommended)
Engine Coolant	8.5 (1.9)	JCB High Performance Antifreeze and Inhibitor/Water → <a href="#">Coolant Mixtures (□ 182)</a>	ASTM D6210
Track Gearbox (each)	0.8 (0.2)	JCB SAE 30 Engine Oil (Not Multigrade)	API CD/SF, MIL-L-46152, MIL-L- 2104D
Track Idler Wheels	0.08 (0.02)	JCB HD90 Gear oil	API-GL-5, MIL-L-2105D
Track Roller (top)	0.03 (0.01)	JCB HD90 Gear Oil	API-GL-5, MIL-L-2105D



## Routine Maintenance

### Fluids, Lubricants and Capacities

Item	Capacity Litres (UK Gal)	Fluid / Lubricant	International Specification
Track Rollers (bottom)	0.08 (0.02)	JCB HD90 Gear Oil	API-GL-5, MIL-L-2105D
Hydraulic Tank	40 (8.8)	JCB Special Hydraulic Fluid Up to 30°C (86°F) JCB Hydraulic Fluid 46 Over 30°C (86°F)	
Slew Ring Bearings		JCB MPL Grease	Lithium based no 2 consistency
Slew Ring Gear Teeth		JCB Slew Pinion Grease	
All Other Grease		JCB MPL Grease	Lithium based no 2 consistency



## Routine Maintenance

### Fluids, Lubricants and Capacities

### Coolant Mixtures

T3-009\_3

Check the strength of the coolant mixture at least once a year, preferably at the start of the cold period.

Replace the coolant mixture according to the intervals shown in the machine's Service Schedule.

### WARNING

**Antifreeze can be harmful. Obey the manufacturer's instructions when handling full strength or diluted antifreeze.**

7-3-4-4\_1

You must dilute full strength antifreeze with clean water before use. Use clean water of no more than a moderate hardness (pH value 8.5). If this cannot be obtained, use de-ionized water. For further information advice on water hardness, contact your local water authority.

The correct concentration of antifreeze protects the engine against frost damage in winter and provides year round protection against corrosion.

The protection provided by JCB High Performance Antifreeze and Inhibitor is shown below.

#### **50% Concentration (Standard)**

Protects against damage down to -40 °C (-39 °F)

#### **60% Concentration (Extreme Conditions Only)**

Protects against damage down to -56 °C (-68 °F)

***Important:*** Do not exceed a 60% concentration, as the freezing protection provided reduces beyond this point.

If you use any other brand of antifreeze:





## Routine Maintenance

### Fluids, Lubricants and Capacities

- Ensure that the antifreeze complies with International Specification ASTM D6210.
- Always read and understand the manufacturer's instructions.
- Ensure that a corrosion inhibitor is included. Serious damage to the cooling system can occur if corrosion inhibitors are not used.
- Ensure that the antifreeze is ethylene glycol based and does not use Organic Acid Technology (OAT).



## Routine Maintenance

Fluids, Lubricants and Capacities

### Fuels



#### Acceptable and Unacceptable Fuels

T3-048

**Important:** No warranty liability whatsoever will be accepted for failure of fuel injection equipment where the failure is attributed to the quality and grade of the fuel used.

Consult your fuel supplier or JCB distributor about the suitability of any fuel you are unsure of.

GEN-9-2

Table 2.

Fuel Specification	Applicable Engines	Service Requirements
EN590 Diesel fuel types - Auto/C0/C1/C2/C3/C4	All	Obey the usual routine maintenance schedules and procedures.
BS2869 Class A2		
ASTM D975-076 2-D, US DF1, US DF2, US DFA		
JIS K2204 Grades 1, 2, 3 and Special Grade 3		



## Routine Maintenance

### Fluids, Lubricants and Capacities

Fuel Specification	Applicable Engines	Service Requirements
ASTM D975-076 1-D	All  <i>Important: Engines operated with these fuels may have a reduced service life.</i>	Obey the usual routine maintenance schedules and procedures. Fuel additives are recommended for use with low sulphur fuels <sup>(1)</sup> . <a href="#">⇒ Additives (□ 187)</a> .
MIL T38219 JP7		
NATO F63		
French EN590 (RME5) with 5% maximum		
AVTURFSII, NATO F34, JP8, MIL T83133, DERD 2463, DEF STAN 91-87	All  <i>Important: Engines operated with these fuels may have a reduced service life.</i>	Obey the usual routine maintenance schedules and procedures. Fuel additives must be used <sup>(1)</sup> . <a href="#">⇒ Additives (□ 187)</a> .
AVCAT FSII, NATO F44, JP5, MIL T5624, DERD 2452, AVTOR		
NATO F35, JET A1, DEF STAN 91-91, DERD 2494, XF63		
AVCAT, NATO F43 (obsolete), JP5 without additives		
JET A (ASTM D1655)		
ASTM D3699 Kerosene		
B5 Biodiesel - RME content blended with mineral derived diesel (5% maximum) - ASTM D6751, DIN 51606, ISO 14214	Tier 3 only <sup>(2)</sup> .	You must obey special routine maintenance schedules and procedures. <a href="#">⇒ Warranty (□ 188)</a> .



## Routine Maintenance

### Fluids, Lubricants and Capacities

Fuel Specification	Applicable Engines	Service Requirements
AVTAG (obsolete)	These fuels are not acceptable with or without additives. Engines must not be operated with these fuels.	
AVTAG FSII (obsolete), NATO F40, JP4, DERD 2454		
JET B (ASTM D1655)		
BS MA100		
JIS K2203 No.2		
Unmodified vegetable oils		

- (1) Use a fuel additive (where instructed) to make sure that the fuel meets the minimum lubricity requirement.
- (2) Refer to Typical Engine Identification Number.



## Routine Maintenance

### Fluids, Lubricants and Capacities

#### Additives

The additives listed below are advertised as being suitable for bringing the lubricity levels of kerosene/low sulphur fuels up to those of diesel fuels. They must be used as specified by your fuel supplier who will understand the concentration level necessary.

**Important:** *The lubricity wear scar diameter must not be more than 460 microns, as tested on a high frequency reciprocating rig at 60°C (140°F). Refer to ISO 12156-1.*

- Elf 2S 1750. Dosage 1000-1500 ppm (0.1 - 0.15%), specifically for Indian Superior Kerosene (SKO) but may be applicable to other fuels.
- Lubrizol 539N. Dosage (on Swedish low sulphur fuel) 250 ppm.
- Paradyne 7505 (from Infineum). Dosage 500 ppm (0.05%).

**Note:** *These products are given as examples only. The information is derived from the manufacturers data. The products are not recommended or endorsed by JCB.*

#### Service Requirements for use of B5 Biodiesel

- The engine oil must be a grade CH4 as minimum specification.
- Do not leave unused B5 biodiesel in the fuel tank for extended periods (top up each day).
- Make sure that 1 in 5 fuel tank fills use standard diesel to EN590 specification, this will help to prevent 'gumming'.
- Make sure regular oil sampling is completed (look for excessive unburnt fuel content, water or wear particles).
- Change the engine oil and filter more frequently (as a minimum half the recommended intervals), or as indicated by oil sampling.
- Change the fuel filters more frequently (as a minimum half the recommended intervals), or if there are engine performance related issues.
- Make sure the fuel is stored correctly, care must be taken to make sure no water enters the machine fuel



## Routine Maintenance

### Fluids, Lubricants and Capacities

tank (or the storage tank). Water will encourage micro-bacterial growth.

- Make sure that the fuel pre-filter is drained daily (not every week as currently advised).
- Only Tier 3 engines (factory filled with CH4 oil) - this is not approved with other manufacturers.
- Use heater kits in low ambient temperature territories.
- The biodiesel must meet the following standards: ASTM D6751, DIN 51606, ISO 14214

**Note:** *If necessary use a test kit to confirm the fuel specification. Testing kits are available (not from JCB currently), use the internet as a source for the kits.*

**Note:** *If performance related issues are to be reported to JCB Service, and the engine has been run on biodiesel, then the fuel system must be filled with standard diesel (at least 2 x tank fills) to EN590 specification and relevant stall speeds recorded prior to making the report.*

### Warranty

JCB have shown a commitment to support the environment by approving the use of biodiesel blended fuels.

Using a B5 blend of biodiesel requires caution and additional servicing of the engine is required. → [Service Requirements for use of B5 Biodiesel \(□ 187\)](#).

Failure to follow the additional recommended service requirements may lead to a warranty claim being declined.

Failures resulting by the incorrect use of biodiesels or other fuel additives are not defects of the engine workmanship and therefore will not be supported by JCB Warranty.

#### Sulphur Content

T3-032

High sulphur content can cause engine wear. (High sulphur fuel is not normally found in North America, Europe or Australia.) If you have to use high sulphur fuel you must change the engine oil more frequently. ⇒ [Table 3. Sulphur Content](#) (□ 189).

Low sulphur fuels must have the appropriate fuel lubricity additives, these lubricity improvers must not create residual deposits that block the fuel system, e.g. injectors, filters etc. Contact your fuel Supplier.

#### CAUTION

**A combination of water and sulphur will have a corrosive chemical effect on fuel injection equipment. It is essential that water is eradicated from the fuel system when high sulphur fuels are used.**

ENG-3-2

Table 3. Sulphur Content

Percentage of sulphur in the fuel (%)	Oil Change Interval
Less than 0.5	Normal
0.5 to 1.0	0.75 of normal
More than 1.0	0.50 of normal



#### Effects of Fuel Contaminates

T3-033

The effect of dirt, water and other contaminants in diesel can be disastrous for injection equipment:

- Dirt - A severely damaging contaminant. Finely machined and mated surfaces such as delivery valves and distributor rotors are susceptible to the abrasive nature of dirt particles - increased wear will almost inevitably lead to greater leakage, uneven running and poor fuel delivery.
- Water - Water can enter fuel through poor storage or careless handling, and will almost inevitably condense in fuel tanks. The smallest amounts of water can result in effects that are just as disastrous to the fuel injection pump as dirt, causing rapid wear, corrosion and in severe cases, even seizure. It is vitally important that water is prevented from reaching the fuel injection equipment. The filter/water trap must be drained regularly.
- Wax - Wax is precipitated from diesel when the ambient temperature falls below that of the fuel's cloud point, causing a restriction in fuel flow resulting

in rough engine running. Special winter fuels may be available for engine operation at temperatures below 0°C (32°F). These fuels have a lower viscosity and limit wax formation.



### Tools

#### Toolbox (if fitted)

The machine has a lockable tool storage container **A** below the seat.

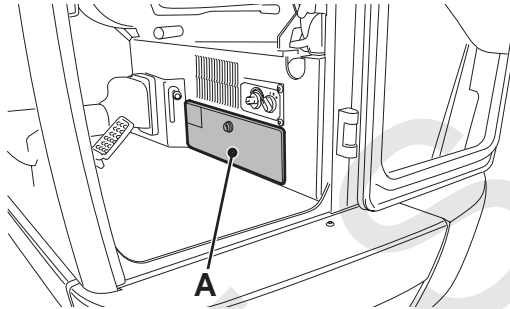

**Fig 70.**

T034120-1

#### Carrying Tools onto the Machine

When you carry tools onto the machine you must maintain three points of contact with the machine at all times. Lift tools onto the machine in intervals if necessary. Place the tools down before you adjust your grips on the machine. Do not try to adjust your grips on the machine while holding tools.

## Prepare the Machine for Maintenance

### Introduction

#### **WARNING**

P11-3001

Maintenance must be done only by suitably qualified and competent persons.

Before doing any maintenance make sure the machine is safe, it should be correctly parked on level ground.

To prevent anyone starting the engine, remove the starter key. Disconnect the battery when you are not using electrical power. If you do not take these precautions you could be killed or injured.

8-3-1-1

Make the machine safe before you start a maintenance procedure.

Unless a maintenance procedure instructs you differently, you must lower the Excavator. Refer to **How to Make the Machine Safe (Excavator Lowered)**.

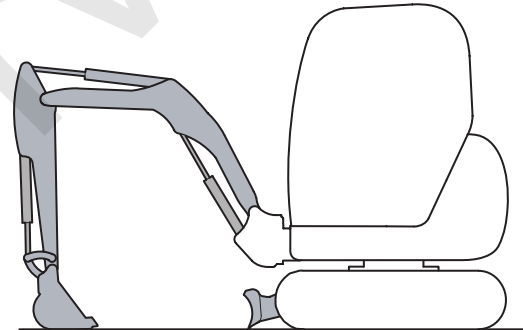

**Fig 71.**

717260-4



### How to Make the Machine Safe (Excavator Lowered)

**Important:** *Unless a maintenance procedure instructs you differently, you must lower the Excavator.*

- 1 Park the machine on level, solid ground.  
  
If necessary, refer to **Stopping and Parking the Machine** in the Operator Manual.
- 2 Lower the dozer.
- 3 Lower the excavator so the attachment is flat on the ground.
- 4 Stop the engine and remove the starter key.
- 5 Disconnect the battery to prevent accidental operation of the engine.

## Cleaning the Machine

### Introduction

Clean the machine using water and or steam. Do not allow mud, debris etc. to build upon the machine.

T3-062\_2

Before carrying out any service procedures that require components to be removed:

- 1 Cleaning must be carried out either in the area of components to be removed or, in the case of major work, or work on the fuel system, the whole engine and surrounding machine must be cleaned.
- 2 When cleaning is complete move the machine away from the wash area, or alternatively, clean away the material washed from the machine.

**Important:** When removing components be aware of any dirt or debris that may be exposed. Cover any open ports and clean away the deposits before proceeding.

### Detergents

Avoid using full strength detergent - always dilute detergents as per the manufacturer's recommendations, otherwise damage to the paint finish may occur.

Always adhere to local regulations regarding the disposal of debris created from machine cleaning.

### Pressure Washing and Steam Cleaning

#### **WARNING**

**When using a steam cleaner, wear safety glasses or a face shield as well as protective clothing. Steam can cause serious personal injury.**

13-3-2-10\_2

### Cleaning the Machine

#### CAUTION

The engine or certain components could be damaged by high pressure washing systems; special precautions must be taken if the engine is to be washed using a high pressure system.

Ensure that the alternator, starter motor and any other electrical components are shielded and not directly cleaned by the high pressure cleaning system.

ENG-3-3

**Important:** Do not aim the water jet directly at bearings, oil seals or electrical and electronic components such as the engine electronic control unit (ECU), alternator or fuel injectors.

Use a low pressure water jet and brush to soak off caked mud or dirt.

Use a pressure washer to remove soft dirt and oil.

**Note:** The machine must always be greased after pressure washing or steam cleaning.

### Preparing the Machine for Cleaning

P11-3004

- 1 Make the machine safe with the excavator lowered. Refer to **Prepare the Machine for Maintenance**.

**Important:** Stop the engine and allow it to cool for at least one hour. Do not attempt to clean any part of the engine while it is running.

- 2 Make sure that all electrical connectors are correctly coupled. If connectors are open fit the correct caps or seal with water proof tape.

## Cleaning the Machine

### WARNING

To avoid burning, wear protective gloves when handling hot components. To protect your eyes, wear goggles when using a wire brush to clean components.

HYD-1-3

### WARNING

Airborne particles of light combustible material such as straw, grass, wood shavings, etc. must not be allowed to accumulate within the engine compartment or in the propshaft guards (when fitted). Inspect these areas frequently and clean at the beginning of each work shift or more often if required. Before opening the engine cover, ensure that the top is clear of debris.

5-3-1-12\_3

### CAUTION

Never use water or steam to clean inside the cab. The use of water or steam could damage the on-board computer and render the machine inoperable. Remove dirt using a brush or damp cloth.

8-3-4-8

Pay particular attention to the following:

- 1 Remove debris and loose articles from inside the cab.
- 2 If the radiator tubes/fins get clogged the radiator will be less efficient.

Brush off all debris from the cooler tubes and fins using a soft bristle brush. Make sure the loosened material is brushed out of the cooler enclosure.

- 3 Debris can collect under the boom. Remove especially all combustible material.

- 4 Do not allow debris to accumulate around the engine, pay particular attention to the exhaust area, remove all combustible material.
- 5 Thoroughly dry piston rams and protect with clean transmission or hydraulic oil if necessary.

## Cleaning the Tracks

P11-3003

### **WARNING**

If two people are doing this job make sure that the person operating the controls is a competent operator. If the wrong control lever is moved, or if the controls are moved violently, the other person could be killed or injured.

If you will be working with another person, make sure that you both understand what is to be done. Learn and use the recognised signalling procedures. Do not rely on shouting - he will not hear you.

To clean the tracks, you must turn them. When the tracks are turning, keep clear of rotating parts. Before starting this job, make sure that you have no loose clothing (cuffs, ties etc.) which could get caught in moving parts. Keep people not involved with this job well away!

MD-3-3-2



## Routine Maintenance

### Cleaning the Machine

- 1 Park the machine on level ground.
- 2 Operate the controls to slew the cab around across the tracks. Lower the bucket to the ground.
- 3 Operate the controls to push the boom down so that the track nearest the bucket is lifted clear of the ground.
- 6 Inspect the track, rollers sprockets and idler wheels for damage or oil leaks. Replace any damaged parts. If in doubt consult your JCB Dealer.
- 7 Operate the controls slowly to lower the track to the ground.
- 8 Operate the controls to position the bucket on the other side of the machine so that steps 2 to 7 can be repeated for the other track.

### WARNING

**Rotating the tracks off the ground may cause stones and other debris to be thrown with considerable force. If you are on the outside, keep well clear. Keep other people well clear.**

8-3-5-8

- 4 Operate the controls to rotate the track which is off the ground. Rotate it one way and then the other to shake off the mud. If necessary the person outside may use water from a hose to help loosen sticky material.
- 5 When the track is clean stop the rotation.



## Checking for Damage

### Check the Machine Body and Structure

T3-063\_4

Make sure that all guards and protective devices are in place, attached by their locking devices and free from damage.

Inspect all steelwork for damage. Note damaged paintwork for future repair.

Check pivot pins are correctly in place and secured by their locking devices.

Check steps and handrails are undamaged and secure.

Check for broken, cracked or crazed window glass and mirrors. Replace damaged items.

Check all lamp lenses for damage.

Check all attachment teeth are undamaged and secure.

Check all safety and instructional labels are in place and undamaged. Fit new labels where necessary.

### Check the Seat and Seat Belt

T3-008\_2

#### **WARNING**

**When a seat belt is fitted to your machine replace it with a new one if it is damaged, if the fabric is worn, or if the machine has been in an accident. Fit a new seat belt every three years.**

2-3-1-7\_1

Inspect the seat belt for signs of fraying and stretching. Check that the stitching is not loose or damaged. Check that the buckle assembly is undamaged and works correctly.

Check that the belt mounting bolts are undamaged, correctly fitted and tightened.



Check seats are undamaged and secure. Check seat adjustments for correct operation.

Do not use the machine if a hose or hose fitting is damaged. Replace damaged hoses before you use the machine again.

## Check the Hydraulic Hoses and Fittings

T3-072

### WARNING

#### Hydraulic Hoses

**Damaged hoses can cause fatal accidents. Inspect the hoses regularly. Do not use the machine if a hose or hose fitting is damaged.**

Replacement hoses must be of the same size and standard.

INT-3-3-2\_4

Inspect the hoses regularly for:

- Damaged hose ends
- Chafed outer covers
- Ballooned outer covers
- Kinked or crushed hoses
- Embedded armouring in outer covers
- Displaced end fittings



### Check the Electrical Circuits

T3-099

Inspect the electrical circuits regularly for:

- Damaged connectors
- Loose connections
- Chafing on wiring harnesses
- Corrosion
- Missing insulation
- Incorrect routing of harness

Do not use the machine if one or more of these faults are found. You must make sure that the electrical circuit is repaired immediately.



## Checking the ROPS/FOPS Structure

### WARNING

**You could be killed or seriously injured if you operate a machine with a damaged or missing ROPS/FOPS. If the Roll Over Protection Structure (ROPS)/Falling Objects Protection Structure (FOPS) has been in an accident, do not use the machine until the structure has been renewed. Modifications and repairs that are not approved by the manufacturer may be dangerous and will invalidate the ROPS/FOPS certification.**

INT-2-1-9\_6

For assistance, contact your JCB distributor. Failure to take these precautions could result in death or injury to the operator.

- 1 Check the structure for damage.
- 2 Make sure that all the ROPS/FOPS mounting bolts are in place and are undamaged.

- 3 Make sure that the ROPS/FOPS mounting bolts are tightened to the correct torque setting.

## Checking the Ram Piston Rods

Extend each ram fully, one at a time and visually examine for score marks, dents or similar defects. If a ram piston appears defective contact your service engineer or JCB dealer.

## Greasing

### Introduction

You must grease the machine regularly to keep it working efficiently. Regular greasing will also lengthen the machine's working life. Refer to the **Service Schedule** for the correct intervals.

T3-028\_2

**Note:** *The machine must always be greased after pressure washing or steam cleaning.*

Greasing should be done with a grease gun. Normally, two strokes of the gun should be sufficient. Stop greasing when fresh grease appears at the joint. Use only the recommended type of grease. Do not mix different types of grease, keep them separate.

In the following illustrations, the grease points are numbered. Count off the grease points as you grease each one. Refit the dust caps after greasing.

**Note:** *Where applicable, refer to the manufacturers manual for instructions on the maintenance of optional attachments.*

### CAUTION

**Waxoyl contains turpentine substitute which is flammable. Keep flames away when applying Waxoyl. Waxoyl can take a few weeks to dry completely. Keep flames away during the drying period.**

**Do not weld near the affected area during the drying period. Take the same precautions as for oil to keep Waxoyl off your skin. Do not breathe the fumes. Apply in a well-ventilated area.**

5-3-1-9

## Pivot Pins

### WARNING

You will be working close into the machine for these jobs. Lower the attachments if possible. Remove starter key and disconnect the battery. This will prevent the engine being started.

8-3-1-3

For the types of grease to use at each point, ⇒ [Fluids, Lubricants and Capacities \(□ 180\)](#). Do not mix different types of grease, keep them separate.

- A Dipper ram pivot pins
- B Bucket ram pivot pins
- C Bucket pivot pins
- D Boom ram pivot pins
- E Kingpost ram pivot pins
- F Swing ram pivot pins

- G Dozer ram pivot pins
- H Dozer arm pivot pins

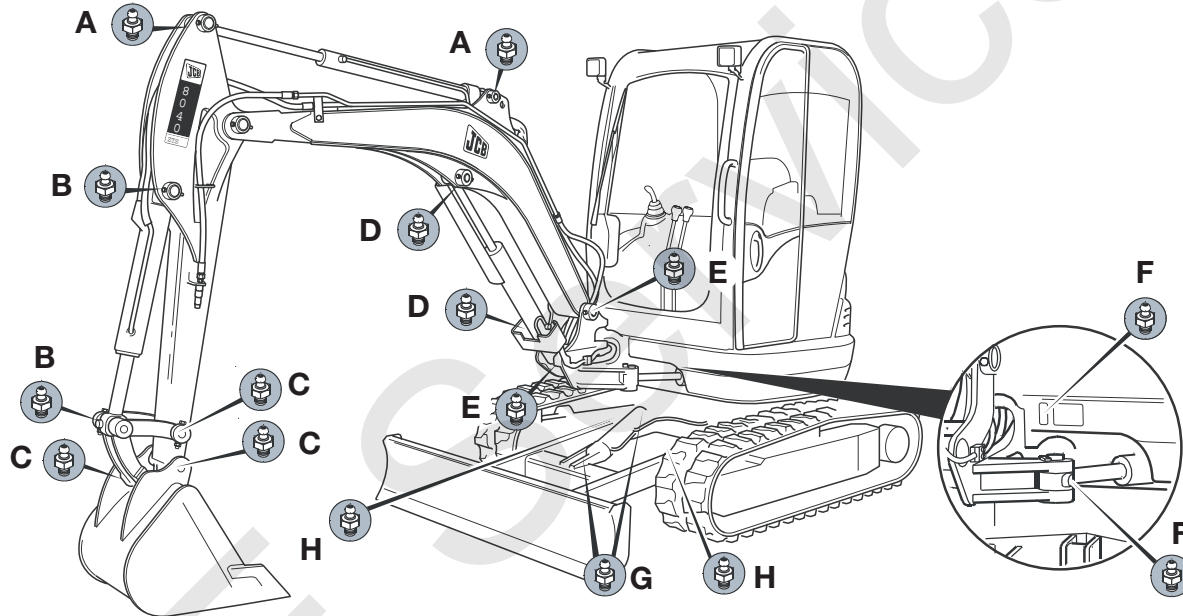

Fig 72.

### Slew Ring Bearings

#### **WARNING**

**Do not overgrease the slew ring as this will result in the displacement of the grease seal.**

8-2-9-35

Ensure the slew ring is kept full of grease. With the cab in the straight ahead position as shown, the grease point **A** is located near the front of the slew ring.

To ensure full distribution of the grease, use the following procedure:

- 1 Grease in, using 4 strokes of the grease gun. Rotate 180°.
- 2 Grease in, using 4 strokes of the grease gun. Rotate 180°.
- 3 Grease in using 4 strokes of the grease gun.

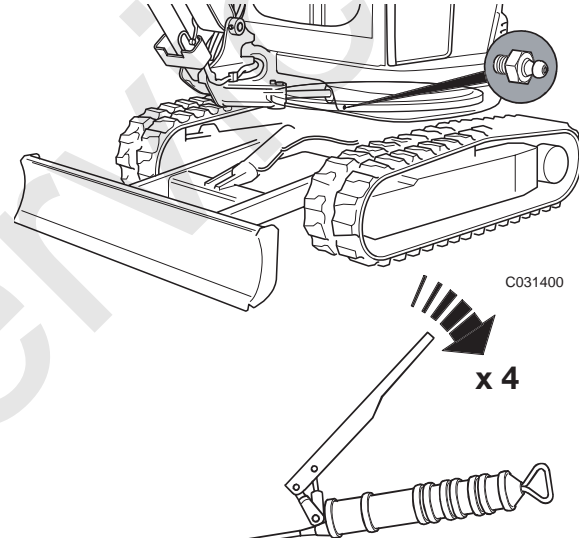

**Fig 73.**



## Slew Ring Gear Teeth

### WARNING

#### Slew Pinion Grease

JCB Slew Pinion Grease is harmful as it contains bitumen compounds 2811. Excessive contact may lead to dermatitis or skin cancer. Always use a barrier cream or wear gloves; wash contaminated skin thoroughly with soap and water. In the event of eye contact, immediately wash with plenty of water and seek medical advice.

8-1-1-7

### WARNING

#### Soft Ground

A machine can sink into soft ground. Never work under a machine on soft ground.

INT-3-2-4

### WARNING

#### Jacking

A machine can roll off jacks and crush you. Do not work under a machine supported only by jacks.

8-3-5-7

- 1 Raise the machine and support the undercarriage.
- 2 Stop the engine and remove the starter key.
- 3 Remove bolts **A** and plate **B** in the underside of the undercarriage. [⇒ Fig 74. \(□ 208\)](#)
- 4 Apply the grease to the pinion using the applicator. [⇒ Fluids, Lubricants and Capacities \(□ 180\).](#)
- 5 Start the engine and rotate the mainframe fully twice.
- 6 Stop the engine and remove the key.

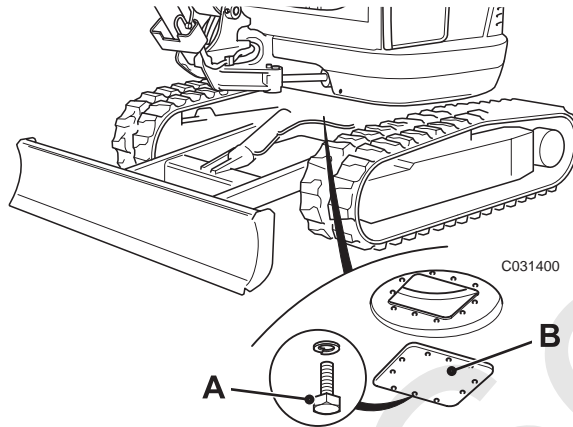

**Fig 74.**

- 7 Repeat steps 4 to 6 as necessary.
- 8 Refit the plate **B** using bolts **A**.
- 9 Lower the machine to the ground.

## Access Panels

### Introduction

When placed in their maintenance position, the access panels give you access to parts or areas of the machine that are not required during machine operation.

T3-100

Before you operate the machine, make sure that all of the access panels are in their operation position and secure.

### Engine Cover

#### Opening the Cover

#### WARNING

**The engine has exposed rotating parts. Switch OFF the engine before working in the engine compartment. Do not use the machine with the engine cover open.**

5-2-6-5

#### WARNING

**Touching hot surfaces can burn skin. The engine and machine components will be hot after the unit has been running. Allow the engine and components to cool before servicing the unit.**

10-1-1-40

- 1 Make the machine safe with the excavator lowered, Refer to *Prepare the Machine for Maintenance*.
- 2 Unlock the cover using the starter key. Release the latch by pushing button **A** and pulling up handle **B** at the same time.

The cover will automatically open and be supported on a gas strut.

#### Closing the Cover

- 1 Make sure that the hydraulic bay cover is closed.
- 2 Push the engine cover down.
- 3 Make sure it is locked in place.

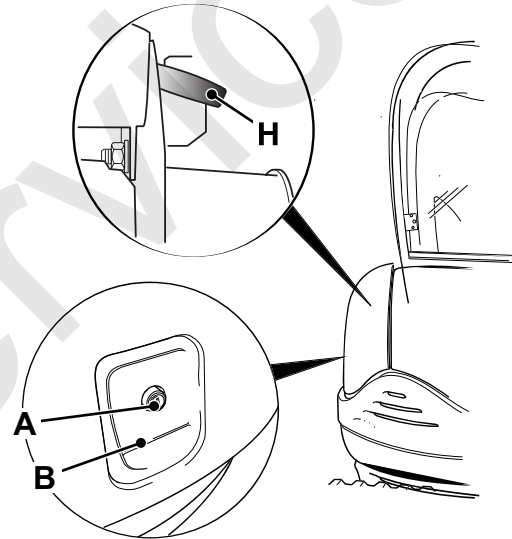

Fig 75.

## Hydraulic Bay Cover

### Opening the Cover

- 1 Make the machine safe with the excavator lowered, Refer to ***Prepare the Machine for Maintenance***.
- 2 Get access to the engine. Refer to ***Access Panels, Engine Cover***.
- 3 Locate handle **H** which is positioned in the top right hand corner of the engine bay, above the air filter.  
[⇒ Fig 75. \(□ 210\)](#)
- 4 Pull the handle **H** to release the catch and lift the cover by its bottom edge while the handle is held in the release position.

### Closing the Cover

- 1 Push the cover down.
- 2 Make sure it is fastened.

### Electrical System

#### Battery

**⚠ CAUTION**

Do not disconnect the battery while the engine is running, otherwise the electrical circuits may be damaged.

INT-3-1-14

#### Battery Access

- 1 Make the machine safe with the excavator lowered, Refer to ***Prepare the Machine for Maintenance.***
- 2 Remove the 4 bolts **A**.
- 3 Remove the lower trim panel **B**.

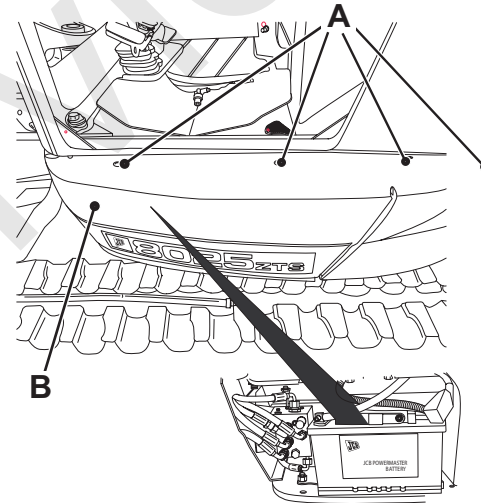

**Fig 76.**

T058960

### Battery Disconnection/Connection

#### **WARNING**

Keep metal watch straps and any metal fasteners on your clothes, clear of the positive (+) battery terminal. Such items can short between the terminal and nearby metal work. If it happens you can get burned.

5-2-2-4

#### Disconnection

- 1 Get access to the battery. [⇒ Battery Access \(□ 212\)](#).
- 2 If the machine has a battery isolator, move the switch to the OFF position then remove the key. [⇒ Battery Isolator \(if fitted\) \(□ 216\)](#).
- 3 Remove the leads. Disconnect the earth (-) terminal first.

#### Connection

- 1 Get access to the battery. [⇒ Battery Access \(□ 212\)](#). Check the battery.
  - a If the terminal is dirty, clean the post.

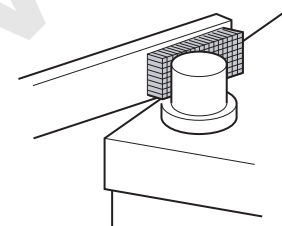

**Fig 77.**

- b If the terminal post is corroded and generates white powder wash the terminal with hot water. If considerable corrosion is detected, clean with a wire brush or abrasive paper.

- c After cleaning, apply a thin coat of petroleum jelly to the terminal.
- 2 Re-connect the leads. Connect the earth (-) terminal last.
- 3 If the machine has a battery isolator, move the switch to the ON position.
- 4 Close and lock the access panels.

### Checking the Electrolyte Level

T3-020\_2

Maintenance free batteries used in normal temperate climate applications should not need topping up. However, in certain conditions (such as prolonged operation at tropical temperatures or if the alternator overcharges) the electrolyte level should be checked as described below.

- 1 Get access to the battery. ⇒ [Battery Access \(□ 212\)](#).

- 2 Disconnect and remove battery. See **Battery Disconnection/Connection**.

### WARNING

**Do not top the battery up with acid. The electrolyte could boil out and burn you.**

2-3-4-6

- 3 Remove covers **A**. Look at the level in each cell. The electrolyte should be 6 mm (1/4 in) above the plates. Top up if necessary with distilled water or de-ionized water.



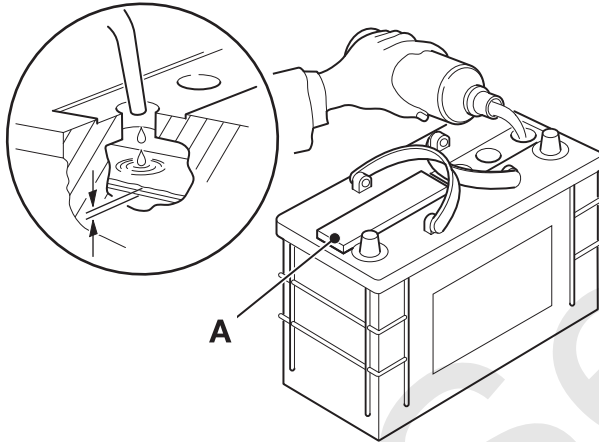

**Fig 78.**

- 4 Refit battery.
- 5 Close and lock the access panels.

#### Battery Isolator (if fitted)

To disconnect the battery from the machine electrics a battery isolator switch has been installed.

### CAUTION

**Before carrying out arc welding on the machine, disconnect the battery and alternator to protect the circuits and components. The battery must still be disconnected even if a battery isolator is fitted.**

INT-3-1-13

To disconnect the machine electrics:

- 1 Open the tool storage cover. [⇒ Toolbox \(if fitted\) \(□ 191\)](#).
- 2 Insert the key **A**, then turn the battery isolation switch to the off position. [⇒ Fig 79. \(□ 216\)](#).

To connect the machine electrics:

- 1 Turn the battery isolation switch **A** to the on position and remove the key.
- 2 Close the tool storage cover.

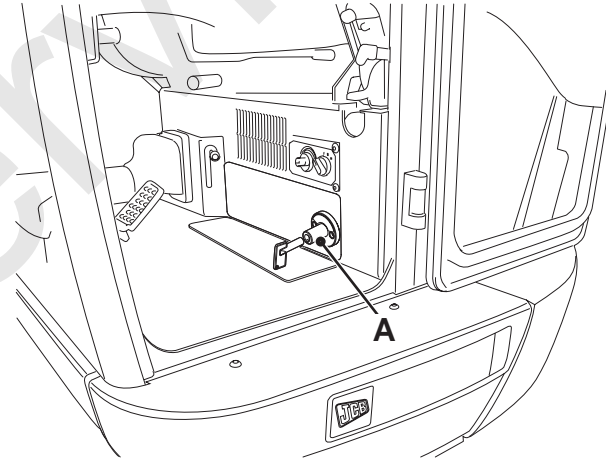

**Fig 79.**

T034130



### Jump Starting the Engine

#### **WARNING**

In temperatures below freezing, the battery electrolyte may freeze if the battery is discharged or poorly charged. Do not use a battery if its electrolyte is frozen. To prevent the battery electrolyte from freezing, keep the battery at full charge.

If you try to charge a frozen battery or jump-start and run the engine, the battery could explode.

Batteries produce a flammable gas, which is explosive; do not smoke when checking the electrolyte levels.

When jump-starting from another vehicle, make sure that the two vehicles do not touch each other. This prevents any chance of sparks near the battery.

Switch off all circuits which are not controlled by the starter switch.

Do not connect the booster (slave) supply directly across the starter motor.

Use only sound jump leads with securely attached connectors. Connect one jump lead at a time.

The machine has a negative earth electrical system. Check which battery terminal is positive (+) before making any connections. Keep metal watch straps and jewellery away from the jump lead connectors and the battery terminals - an accidental short could cause serious burns and damage equipment. Make sure you know the voltage of the machine. The booster (slave) supply must not be higher than that of the machine. Using a higher voltage supply will damage your machine's electrical system. If you do not know the voltage of your booster (slave) supply, then contact your JCB dealer for advice. Do not attempt to jump-start the engine until you are sure of the voltage of the booster (slave) supply.

8-2-7-4

**Note:** The machine has a 12 Volt electrical system. Using a booster (slave) supply with a higher voltage will damage the machine's electrical system. The negative (-) terminal on the battery is connected to frame earth.

### DANGER

**Before lowering the attachments to the ground, make sure that the machine and the area around it are clear of other people. Anyone on or close to the machine could fall and be crushed by the attachments, or get caught in the linkages.**

2-2-3-4

- 1 Lower the attachments to the ground.

Lower the excavator bucket and dozer to the ground, if they are not already there. They will lower themselves under their own weight when you operate the control. Operate the control carefully to control the rate of descent.

- 2 Set all switches in the cab to 'OFF'.

- 3 Get access to the battery. → [Battery Access \(□ 212\)](#).

- 4 Connect the booster cables.

- a Connect the positive booster cable to the positive (+) terminal on the machine battery. Connect the other end of this cable to the positive (+) terminal of the booster supply.
- b Connect the negative (-) booster cable to a good frame earth on the machine, away from and below the battery.

**Note:** A good frame earth is part of the machine frame, free from paint and dirt. Do not use a pivot pin for an earth.

- c connect the other end of this cable to the negative (-) terminal on the booster supply.

- 5 Do the pre-start checks.

- 6 Start the engine.



- 7** Disconnect the booster cables
  - a** Disconnect the negative booster cable from the machine frame earth. Then disconnect it from the booster supply.
  - b** Disconnect the positive booster cable from the positive (+) terminal on the battery. Then disconnect it from the booster supply.

### Fuses

#### Introduction

#### CAUTION

##### Fuses

Always replace fuses with ones of correct ampere rating to avoid electrical system damage.

8-3-3-5

The electrical circuits are protected by fuses. If a fuse blows, find out why before fitting a new one.

Two primary fuses **A** and **B** are located in the battery compartment below the cab door. → [Fig 80.](#) (□ 220).

The secondary fuses are in the fuse box located below the operator's seat. → [Fig 81.](#) (□ 221).

Open panel **C** using the starter key. Pull off the cover to gain access to the fuses.

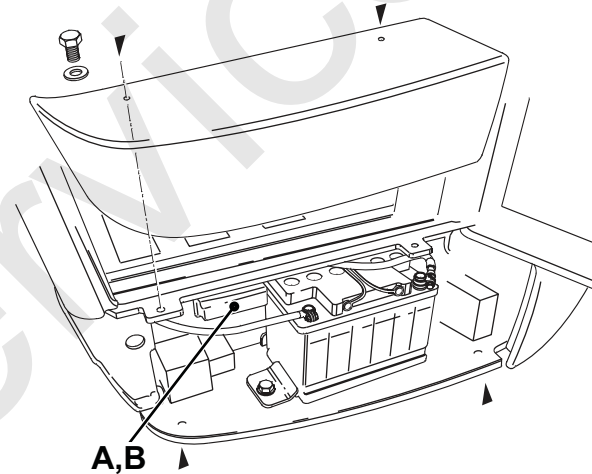

**Fig 80. Primary Fuses**

### All Machines

Table 4.

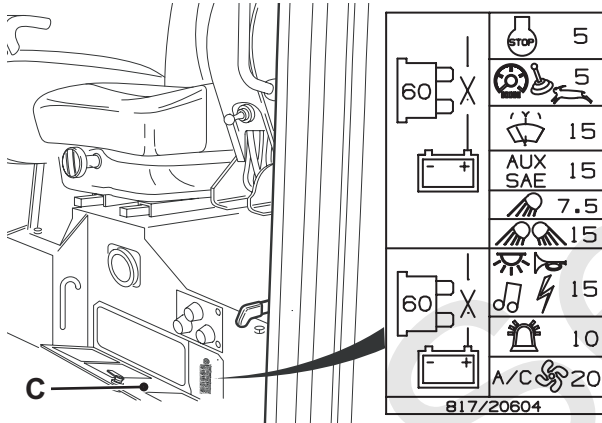

Fig 81.

862330-3

Fuse No.	Circuit	Rating (Amps)
1	Engine Stop Solenoid	5
2	Instruments, Two-speed Circuit, Servo Solenoid	5
3	Wash/Wipe Circuit	15
4	Slew/Swing Circuit, SAE Control	15
5	Boom Light	7.5
6	Work Lights	15
7	Interior Light, Horn, Radio, Accessory Power Socket	15
8	Beacon	10
9	Heater Blower and Air Conditioning	20
A	Primary fuse	60
B	Primary fuse	60

## Engine

### Oil and Filter

#### Checking the Oil Level

- 1 Get access to the engine. Refer to **Access Panels, Engine Cover**.
- 2 Open the engine cover. Allow time for the oil to drain back into the engine sump before taking a reading. If insufficient time is given a false low reading may be recorded which will result in overfilling the engine.
- 3 Withdraw dipstick and wipe clean, re-insert fully into tube and withdraw to check level. The correct level will show the oil at the top of the hatched area of the dipstick **A**. → [Fig 82.](#) (□ 222).

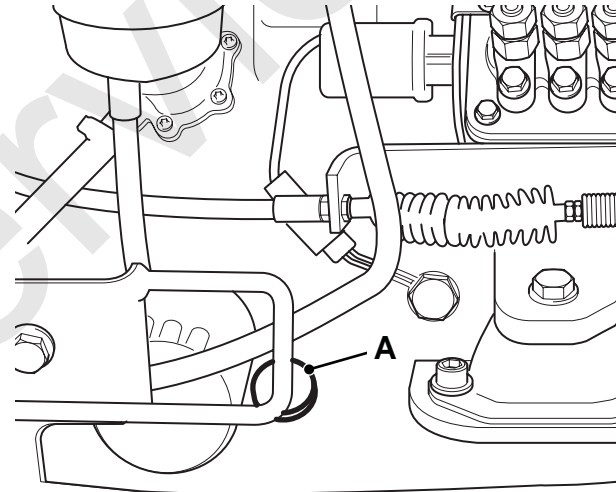

Fig 82.



### CAUTION

The engine has a closed ventilation system, (a hose connects the ventilation system and the inlet manifold). When oil is added through the oil filler it is important that the oil is added slowly. If the oil is added too rapidly it will enter the cylinders through the hose and intake manifold and cause serious engine damage.

8-3-5-10

- 4 If necessary add oil slowly through the remote filler.

Do not insert the container neck **Z** completely into the remote filler hole. → [Fig 83.](#) ([□ 223](#)).

Allow oil to flow down from the remote filler to the crankcase.

Replace filler cap securely. Use only the recommended oil.

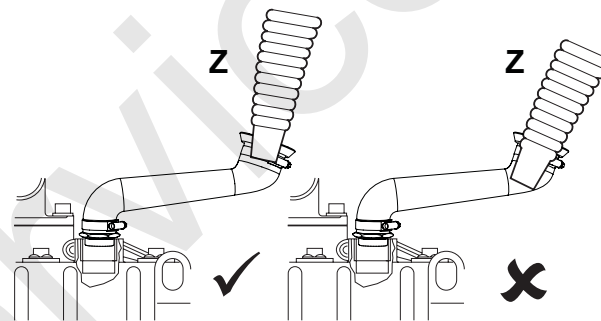

**Fig 83.**

### Changing the Oil and Filter

#### WARNING

Hot oil and engine components can burn you. Make sure the engine is cool before doing this job.

Used engine crankcase lubricants contain harmful contaminants. In laboratory tests it was shown that used engine oils can cause skin cancer.

8-3-1-4

#### CAUTION

Keep your face away from the drain hole when removing the drain plug.

2-3-3-4

- 1 Remove the engine skid plate to gain access to the engine drain plug (if necessary).
- 2 Place a container beneath the engine (to catch the oil). Remove the drain plug **A**. Let the oil drain out,

then clean and refit the drain plug.  
⇒ [Fig 84. \(□ 225\)](#).

#### CAUTION

The oil filter canister will contain some oil which could spill out when you remove the canister.

MD-3-2-1

- 3 Unscrew the filter canister **B**. If necessary use a chain or strap wrench. Clean the filter mounting face.

Smear the seal on the new filter canister with oil. Screw in the new canister - hand tight and then one quarter turn.

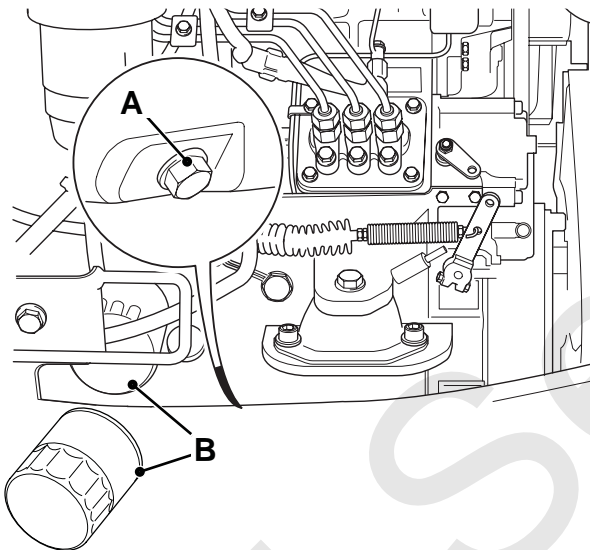

Fig 84.

- 4 Fill the engine with new oil through the filler. DO NOT insert the container neck Z completely into the filler hole. → [Fig 83.](#) (□ 223).
  - 5 Allow oil to flow down from the filler to the crankcase. Replace filler cap securely. Use only the recommended oil.
- Important:** Oil must be added slowly.
- 6 Wipe off any spilt oil. Check for leaks. Make sure that the filler cap is correctly refitted

### Cooling System

#### Checking the Coolant Level

#### **WARNING**

The cooling system is pressurised when the coolant is hot. When you remove the cap, hot coolant can spray out and burn you. Make sure that the engine is cool before you work on the cooling system.

9-3-3-1\_2

- 1 Get access to the engine. Refer to **Access Panels, Engine Cover**. Allow the engine to cool.
- 2 Observe the coolant fluid in the expansion bottle, the bottle **A** should be half full of coolant. [→ Fig 85. \(□ 226\)](#).
- 3 Top up the system, if required by carefully removing the expansion tube filler cap **B**, top up the level to the neck of the expansion tube.

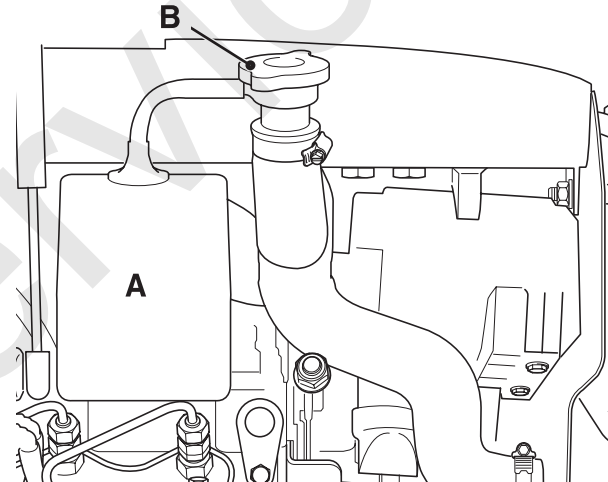

**Fig 85.**

### Changing the Coolant

#### CAUTION

Keep your face away from the cylinder block tap and the radiator drain plug when you drain the system.

MD-3-1-6

- 1 Get access to the engine. Refer to **Access Panels, Engine Cover**. Allow the engine to cool.
- 2 Carefully and slowly remove the radiator cap allowing any trapped pressure to escape.
- 3 Undo the plug **B** on the cylinder block and let the coolant drain out. Remove the bottom radiator hose **C** by unfastening at clip **D** and let the coolant drain out. Make sure the drain hole is not blocked. [→ Fig 86. \(□ 227\)](#).
- 4 Flush the system with clean water if necessary.

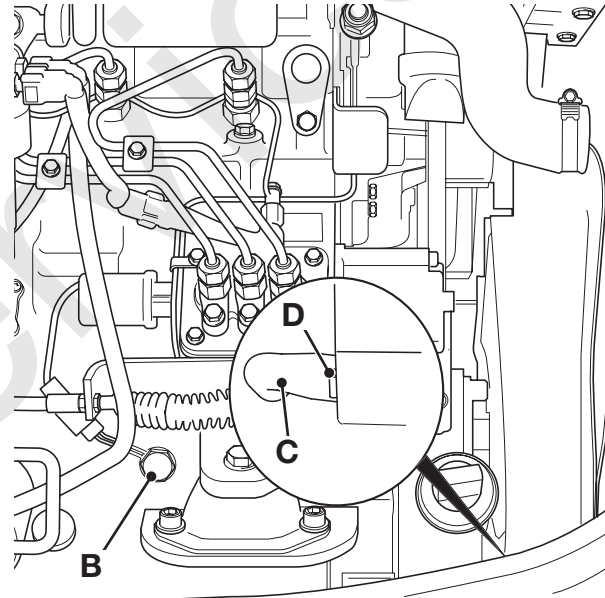

Fig 86.



- 5 Refit the plug **B**. Refit bottom hose **C** and secure with hose clip **D**.
- 6 Fill the system. Use the correct mix of clean, soft water and anti-freeze. → [Coolant Mixtures \(□ 182\)](#).
- 7 Refit the filler cap **A** making sure that it is tight.
- 8 Run the engine for a while, to raise the coolant to working temperature and pressure. Stop the engine. Check for leaks.

**Note:** *Manually squeeze the top and bottom radiator hoses during filling to displace any trapped pockets of air and to prevent air locks*

### Fan Belt

#### Adjusting the Fan Belt

- 1 Get access to the engine. Refer to **Access Panels, Engine Cover**.
- 2 Check that there is 5mm (0.2in) slack midway between the alternator pulley and the crankshaft pulley.
- 3 If necessary, adjust the fan belt as follows:
  - a Slacken lock nut **B**. → [Fig 87. \(□ 229\)](#).
  - b Turn screw **C** until there is 5mm (0.2in) slack midway between the alternator pulley and the crankshaft pulley.
  - c Tighten lock nut **B**.

**Important:** Excessive fan belt slack may result in damage to the engine timing cover.

- 4 Close the engine cover.

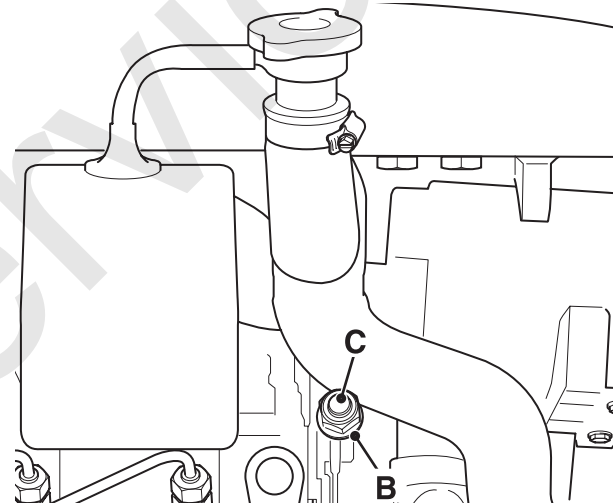

**Fig 87.**

### Air Filter

#### Changing the Outer Element

- 1 Get access to the air filter. Refer to **Access Panels, Engine Cover** and **Access Panels, Hydraulic Bay Cover**.
- 2 Undo the two retaining clips holding the cover **A** and remove the element **B** by twisting anti-clockwise. Do not tap or knock the element as you remove it. → [Fig 88.](#) (□ 230).
- 3 Clean the inside of canister and dust valve with a vacuum cleaner.
- 4 Prior to fitting new element, smear the seal on the end of the element with grease. Temporarily insert the filter element into the canister ensuring its correct location. Withdraw the element and check that there is a continuous grease witness mark around the base of the canister. This shows that the canister has not been distorted which would allow unfiltered air to

bypass the element. Refit the element and cover. Check all air hoses for condition and security.

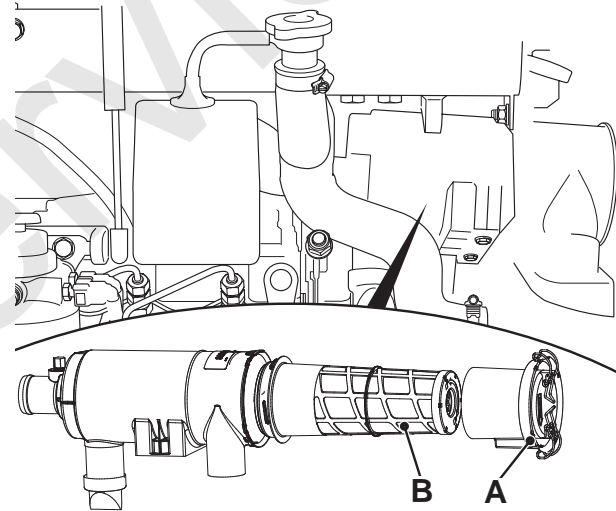

Fig 88.



### Changing the Inner Element

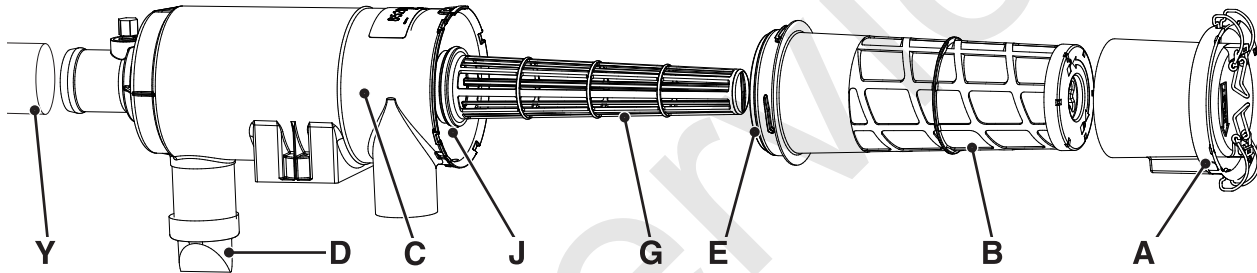

Fig 89.

C035060

- 1 Get access to the air filter. Refer to **Access Panels, Engine Cover**.
- 2 To prevent dust getting into the engine, remove the induction hose **Y**. Cover the hose to prevent rain and dirt getting into the engine. → [Fig 89. \(□ 231\)](#).
- 3 Undo the two retaining clips holding the cover **A** and remove the element **B** by twisting anti-clockwise.
- 4 Remove inner element **G**.
- 5 Clean inside of canister **C** and dust valve **D** with a vacuum cleaner.



- 6 Smear the seal **J** of new inner element and carefully insert into canister making sure that it seats correctly. Withdraw element and check for continuous grease witness mark on the canister base. Refit element.
- 7 Follow the same practice when fitting outer element, this time smearing seal **E** with grease, inserting element correctly, withdrawing and checking for continuous grease witness mark. Refit element.
- 8 Remove cover from induction hose **Y** and refit. Check security and condition of all air hoses.

**Note:** *In a dusty working environment, the outer element may have to be changed more frequently than the Service Schedule recommendation. A new inner element must be fitted at latest every third time the outer element is changed. As a reminder, mark the inner element with a felt tip pen each time the outer element is changed.*

## Fuel System

### Introduction

#### **WARNING**

##### Fuel

Fuel is flammable; keep naked flames away from the fuel system. Stop the engine immediately if a fuel leak is suspected. Do not smoke while refuelling or working on the fuel system. Do not refuel with the engine running. Completely wipe off any spilt fuel which could cause a fire. There could be a fire and injury if you do not follow these precautions.

INT-3-2-2\_3

#### **WARNING**

Fine jets of fluid at high pressure can penetrate the skin. Keep face and hands well clear of pressurised fluid and wear protective glasses. If fluid penetrates your skin, get medical help immediately.

0177



#### CAUTION

Do not allow dirt to enter the system. Before disconnecting any part of the system, thoroughly clean around the connection. When a component has been disconnected, always fit protective caps and plugs to prevent dirt ingress.

Failure to follow these instructions will lead to dirt entering the system. Dirt in the system will seriously damage the systems components and could be expensive to repair.

INT-3-3-12

#### CAUTION

Running the engine with air in the system could damage the fuel injection pump. After maintenance, the system must be bled to remove any air.

2-3-3-11

### Water Separator and Engine Fuel Filter

#### Draining the Fuel Filter/Sedimenter

- 1 Get access to the engine. Refer to **Access Panels, Engine Cover**.
- 2 Locate the sedimenter under the engine compartment at the front in a central position.
- 3 If there is any sediment in the bowl replace the fuel filter element. → [Replacing the Fuel Filter Element \(□ 236\)](#). If there is water but no sediment, drain off the water by opening tap **B**.

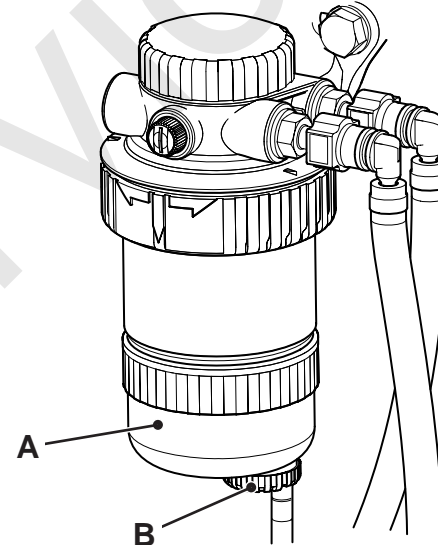

Fig 90.

### Replacing the Fuel Filter Element

If the bowl **A** contains sediment carry out the following:

- 1 Get access to the engine. Refer to **Access Panels, Engine Cover**.
- 2 Drain the sediment bowl **A**. ⇒ [Draining the Fuel Filter/Sedimenter \(□ 235\)](#).
- 3 Unscrew the filter and sediment bowl from the filter head **B**.
- 4 Unscrew the sediment bowl **A** from the filter **C** and wash the bowl. Use clean fuel.
- 5 Re-assemble new filter to bowl and refit to filter head **B**.
- 6 Bleed the system. ⇒ [Bleeding the System \(□ 238\)](#).

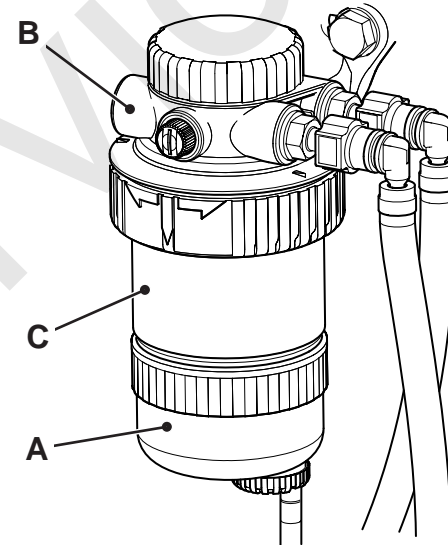

Fig 91.

### Replacing the Fuel Pre Filter Element

- 1 Get access to the engine. Refer to **Access Panels, Engine Cover**.
- 2 Clamp the fuel hoses **A**. [⇒ Fig 92. \(□ 237\)](#).
- 3 Disconnect the fuel hose clips **B**.
- 4 Remove the bolt **C**, Collect the washer, Remove the fuel pre filter **D**.
- 5 Install new filter in reverse order.
- 6 Bleed the system. [⇒ Bleeding the System \(□ 238\)](#).

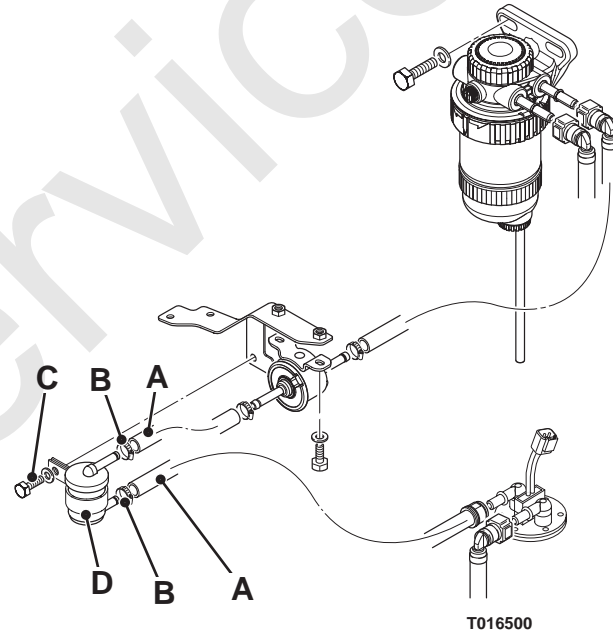

Fig 92.

## Bleeding the System

### WARNING

To bleed the injectors you must turn the engine. When the engine is turning, there are parts rotating in the engine compartment.

Before starting this job make sure that you have no loose clothing (cuffs, ties etc) which could get caught in rotating parts.

When the engine is turning, keep clear of rotating parts.

2-3-3-8

- 1 Get access to the engine. Refer to **Access Panels, Engine Cover**.
- 2 To bleed air from the filter, slacken bleed screw **A**. Switch ignition to ON position (This will start the electric fuel pump). → [Fig 93. \(□ 239\)](#).
- 3 Retighten bleed screw **A** when all air has been removed.



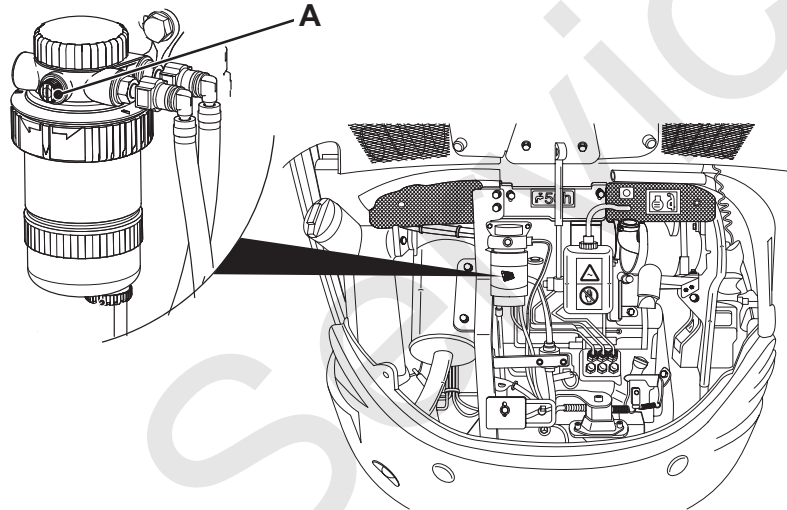

Fig 93.

T015790-2

## Hydraulic System

### Introduction

#### **WARNING**

The temperature of the hydraulic oil will be high soon after stopping the engine. Wait until it cools (less than 40°C) before beginning maintenance.

8-3-4-10

#### **WARNING**

##### Fluid Under Pressure

Fine jets of fluid at high pressure can penetrate the skin. Keep face and hands well clear of fluid under pressure and wear protective glasses and gloves. Hold a piece of cardboard close to suspected leaks and then inspect the cardboard for signs of fluid. If fluid penetrates your skin, get medical help immediately.

INT-3-1-10\_3

#### **WARNING**

##### Hydraulic Pressure

Hydraulic fluid at system pressure can injure you. Before connecting or removing any hydraulic hose, residual hydraulic pressure trapped in the service hose line must be vented. Make sure the hose service line has been vented before connecting or removing hoses. Make sure the engine cannot be started while the hoses are open.

INT-3-1-11\_2

#### **CAUTION**

Using incorrect fluid could damage the system. See Fluids, Capacities and Lubricants for the correct fluid. The fluid can harm your skin. Wear rubber gloves. Cover cuts or grazes.

2-3-5-1\_2



#### CAUTION

Do not allow dirt to enter the system. Before disconnecting any part of the system, thoroughly clean around the connection. When a component has been disconnected, always fit protective caps and plugs to prevent dirt ingress.

Failure to follow these instructions will lead to dirt entering the system. Dirt in the system will seriously damage the systems components and could be expensive to repair.

INT-3-3-12



### Releasing the Hydraulic Pressure

- 1 Make the machine safe with the boom lowered. Refer to **Prepare the Machine for Maintenance**.
- 2 Operate the controls to remove the hydraulic pressure from the service hose lines:
  - a For manually operated services, operate the controls (several times) of the service(s) to be disconnected.
  - b For electrical services, turn the starter key to the ON position.

Operate the controls (several times) of the service(s) to be disconnected. Set the starter switch to the OFF position then remove the starter key.

- c Press the relevant console switch (to make the relevant service active). **Refer to Operation Section**.

**Important:** To release the hydraulic pressure from the electrical and servo operated services the battery must be connected while you operate the controls.

- 3 Carefully remove the hydraulic tank filler cap to vent residual tank hydraulic pressure.
- 4 Install the hydraulic tank filler cap.

### Oil and Filter

#### Checking and Adjusting the Fluid Level

- 1 Make the machine safe with the boom lowered. Refer to ***Prepare the Machine for Maintenance***.
- 2 Check the Level

Open the engine cover and hydraulic bay cover.  
 ⇒ [Access Panels \(□ 209\)](#).

Check the level indicator **A**. The fluid level should be visible in the level indicator. ⇒ [Fig 94. \(□ 243\)](#).

- 3 Top up fluid level if necessary

Remove filler cap **B**, add fluid. Ensure that only correct grade of fluid is used. ⇒ [Fluids, Lubricants and Capacities \(□ 180\)](#).

- 4 Refit the filler cap.

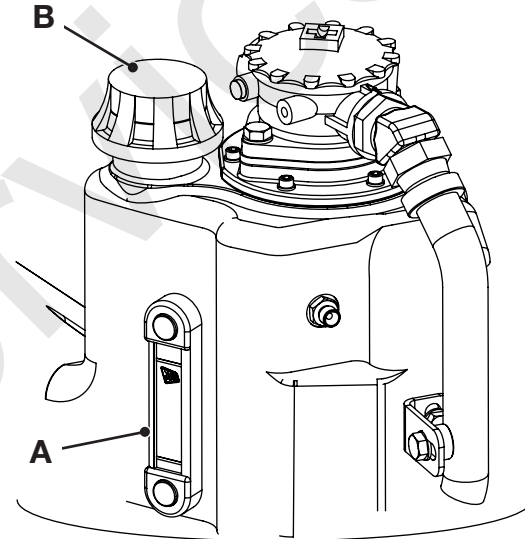

**Fig 94.**

#### Replacing the Hydraulic Filter

- 1 Open the engine cover and hydraulic bay cover.  
⇒ [Access Panels \(□ 209\)](#).
- 2 Unscrew cap **B** and spring **C**. ⇒ [Fig 95. \(□ 244\)](#).
- 3 Withdraw bypass valve **D**, cartridge filter **E** and seal **F**.
- 4 Clean all metal parts. Reassemble using new cartridge filter **E** and seal **F**.
- 5 Top up hydraulic fluid. ⇒ [Checking and Adjusting the Fluid Level \(□ 243\)](#)
- 6 Replace bypass valve **D**, spring **C** and cap **B**.

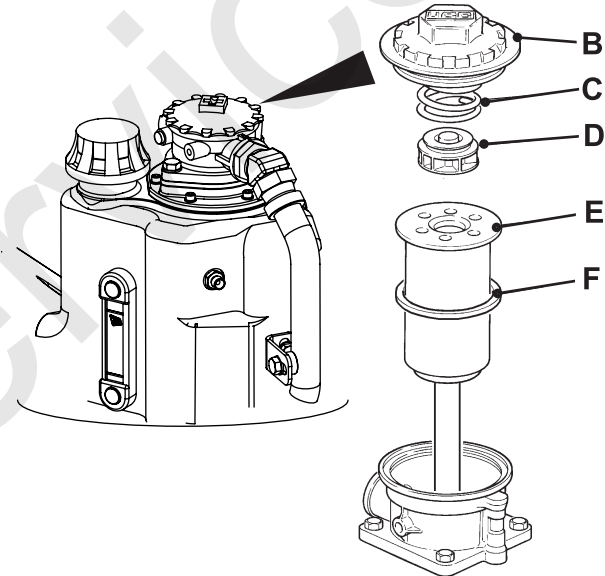

Fig 95.

### Tracks and Running Gear

#### Tracks

##### Checking the Track Gearbox Oil Level

- 1 Make the machine safe with the excavator lowered, Refer to ***Prepare the Machine for Maintenance***.
- 2 Ensure that the gearbox plugs **A** and **B** are positioned as shown. Stop the engine and remove starter key.
- 3 Clean the area around the fill/level plug **A** and remove the plug, oil should be seen to be level with the hole.
- 4 Top up as necessary. → [Fluids, Lubricants and Capacities \(□ 180\)](#). Clean and refit the plug, make sure it is tight.

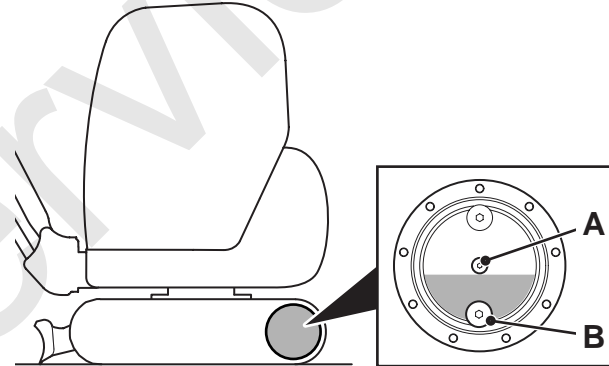

Fig 96.

717260-6

#### Changing the Track Gearbox Oil

- 1 Make the machine safe with the excavator lowered. Refer to ***Prepare the Machine for Maintenance***.
- 2 Place a suitable container beneath the drain plug **B** to collect the oil.

#### CAUTION

**Oil will gush from the hole when the drain plug is removed. Keep to one side when you remove the plug.**

2-3-4-2

- 3 Remove level/filler plug **A**. Remove the drain plug **B**. Allow the oil to drain out. Wipe the drain plug clean. Make sure that you remove all metal particles. Refit the drain plug. Make sure it is tight.
- 4 Fill with new oil through the fill/level plug hole until oil runs from the hole. → [Fluids, Lubricants and Capacities \(180\)](#).

- 5 Run the machine, operate the track controls and then make sure there are no leaks.

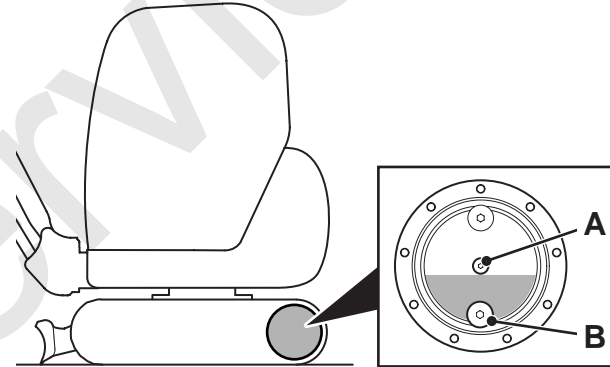

Fig 97.

717260-6



#### Checking the Track Tension

#### CAUTION

Recoil unit servicing must only be carried out by JCB distributors. You could be killed or injured if you tamper with it.

8-3-3-4

#### 1 Prepare the Machine

Park the machine on level ground. Run it backwards and forwards several times. Stop the machine after running it forwards.

#### 2 Set the machine in the posture shown with the track to be checked raised from the ground and supported. ⇒ [Fig 98.](#) ([□ 248](#)).

#### 3 Check the Tension:

Check that the tension measurement at **A** is between 60mm (2.4in) and 65mm (2.6in) for rubber tracks and 120mm (4.8in.) for steel tracks. ⇒ [Fig 98.](#) ([□ 248](#))

#### CAUTION

Always make sure that the track tension measurement is not less than specified or severe strain to the track will result.

8-3-3-3

#### 4 Adjust the track tension.

#### a To tighten the track:

Pump grease through nipple **B** in adjusting screw **C** until track tension is correct. ⇒ [Fluids, Lubricants and Capacities](#) ([□ 180](#)).

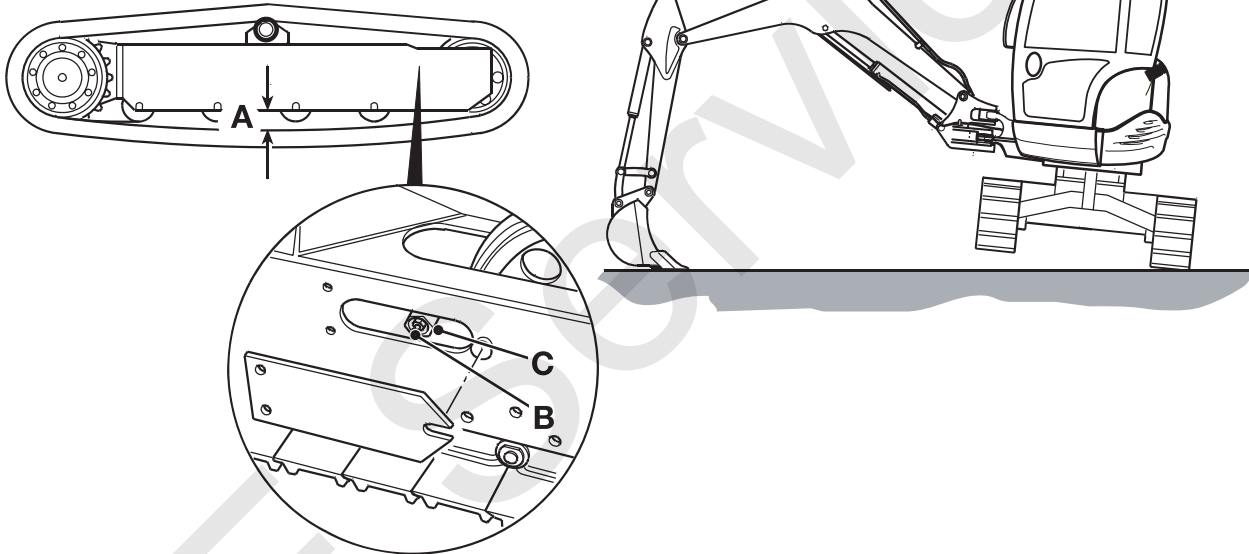

Fig 98.



Rotate track and re-check dimension **A**.

**b** To slacken the track:

Slacken adjusting screw **C** until track tension is correct.

Rotate track and re-check dimension **A**.

**5** Refit the cover plate. Lower the track to the ground.

**Note:** *Track tension will increase during rotation. Check the track tension at its tightest point to avoid over tensioning.*

## Fire Extinguisher (if fitted)

T3-022

### Checking the Fire Extinguisher

Check the fire extinguisher for damage, security and signs of leaking.

Check that the gauge **A** indicates that the extinguisher is charged i.e. the needle is in the GREEN segment.

**Note:** *If the needle is in or very near the RED segment at either end of the gauge, the extinguisher must be serviced or replaced.*

Make sure the safety pin **B** is fitted and secure.

The extinguisher should be serviced every 12 months by a suitably qualified person.

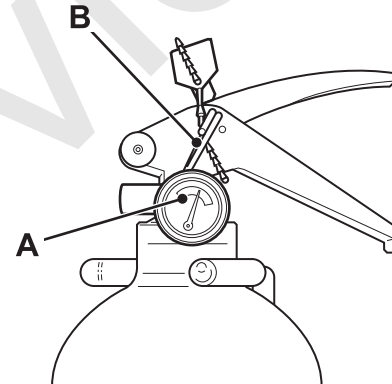

**Fig 99.**



---

# Optional Attachments

## Introduction

T4-002\_3

### **WARNING**

Use only the JCB approved attachments that are specified for your machine. Operating with non-specified attachments can overload the machine, causing possible damage and machine instability which could result in injury to yourself or others.

**The use of non-approved attachments could invalidate your warranty.**

2-4-5-2\_1

### **CAUTION**

If you have an attachment which is not covered in the Operator Manual do not install it, use it or remove it until you have obtained, read and understood the pertinent information. Install attachments only on the machines for which they were designed.

5-5-1-1\_2

A wide range of optional attachments is available to increase the versatility of your machine. Only JCB approved attachments are recommended for use with your machine. Consult your JCB Distributor for the full list of approved attachments available.



This part of the manual includes general information on attachment operation and instructions for installation and removal of attachments.

Some attachments are supplied complete with instructions on safety, installing and removing, operation and maintenance. Read and fully understand the information before fitting, using and servicing the attachment. If there is anything you do not understand, ask your JCB Distributor.

Before using any attachment, read again ***Working With The Machine*** in the Operation section and consider how the attachment is going to affect operational safety. With the attachment fitted, there may be changes in the machine's centre of gravity or overall dimensions. This could have an effect on, for example, machine stability, the gradients on which it is safe to operate or the safe distance from power lines.

Practice using attachments off the job before working with them for the first time.

JCB attachments are designed and manufactured specifically to suit the machine's hydraulic system, mounting arrangements and safe load requirements. Attachments which are not designed for use with this machine may cause damage and create safety hazards for which JCB cannot be held responsible. In addition the machine's warranty and any other legislative compliance may be affected by the use of non JCB approved attachments.

If your machine needs the hydraulic system adapting to facilitate the use of auxiliary attachments, you must consult your distributor. Only suitably qualified personnel must re-route hydraulic hoses.

All optional attachments will have limits on their operation. i.e. lifting capacity, speeds, hydraulic flow rates, etc. Always check in the literature supplied with the attachment or in the Specification section of this manual. Some specification limits may also be displayed on the attachments Data/Rating Plate.



---

**⚠ CAUTION**

Some attachments may contact parts of the machine when in the fully folded position. Take extra care to avoid damage to the machine.

---

3-4-1-4



### Attachments For Your Machine

Attachments will help increase the productivity of your machine, for more information contact your JCB Distributor.

Remember, do not operate attachments until you have read and fully understand the attachment operating instructions.

**Important:** Do not operate or work with attachments until the machine hydraulic oil has reached its normal working temperature.

#### **WARNING**

##### **Earth Drills and Breakers**

**Operation of this machine with an earth drill or breaker fitted will alter machine stability. Refer to the attachments stability page before working on inclines.**

8-4-5-6



### Impact Protection

#### **WARNING**

When using an attachment for example a hydraulic breaker, where the risk of flying debris is present, a protective layer or screen guard must be attached to the front of the cab to protect the operator from flying debris which could cause injury.

8-5-1-5

The decal **A** warns the operator against the risk of flying debris when using an attachment. The attachment must not be used if a protective layer or screen guard has not been fitted to the machine. → [Fig 100.](#) ([□ 255](#)).

Make sure that the attachment for example a hydraulic breaker **B** is positioned in front of the cab, before it is operated. Do not swing the boom to the side during operation of the attachment.

Consult your JCB dealer for further information.

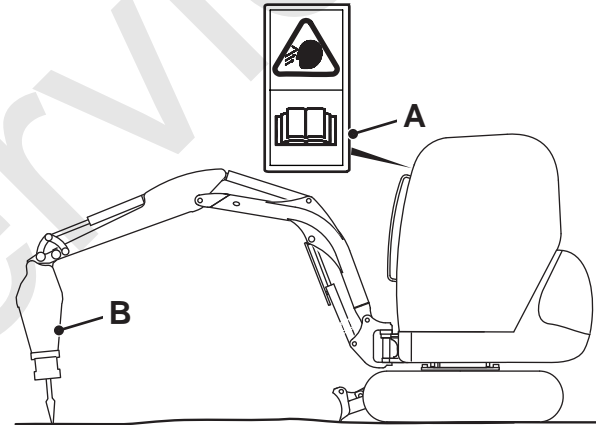

**Fig 100.**

732000-4



# Connecting/Disconnecting Hydraulic Hoses

T4-004\_2

## Introduction

### **WARNING**

#### Fluid Under Pressure

Fine jets of fluid at high pressure can penetrate the skin. Keep face and hands well clear of fluid under pressure and wear protective glasses and gloves. Hold a piece of cardboard close to suspected leaks and then inspect the cardboard for signs of fluid. If fluid penetrates your skin, get medical help immediately.

INT-3-1-10\_3

### **WARNING**

#### Hydraulic Pressure

Hydraulic fluid at system pressure can injure you. Before connecting or removing any hydraulic hose, residual hydraulic pressure trapped in the service hose line must be vented. Make sure the hose service line has been vented before connecting or removing hoses. Make sure the engine cannot be started while the hoses are open.

INT-3-1-11\_2

Some attachments are hydraulically powered. The following procedures show how to connect and disconnect the hydraulic hoses safely.

#### Connecting the Hydraulic Hoses

- 1 Make the machine safe. Refer to ***Routine Maintenance, Prepare the Machine for Maintenance.***
- 2 Vent the hydraulic system. Refer to ***Routine Maintenance, Releasing the Hydraulic Pressure.***
- 3 If necessary, remove the blanking caps.
- 4 Check the hoses and adaptors for damage. Refer to ***Routine Maintenance, Checking for Damage.***
- 5 Connect the hoses.

If the hoses have quick releases couplings, refer to ***Quick Release Couplings.***

- a Make sure that the hose is not twisted. Pressure applied to a twisted hose can cause the hose to fail or the connections to loosen.

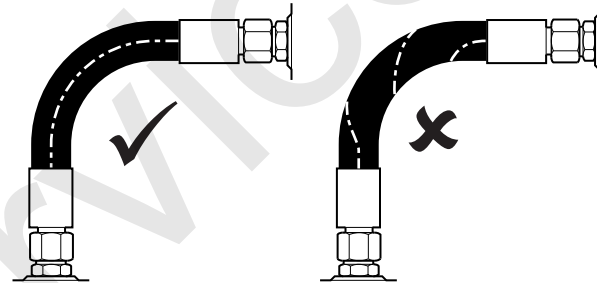
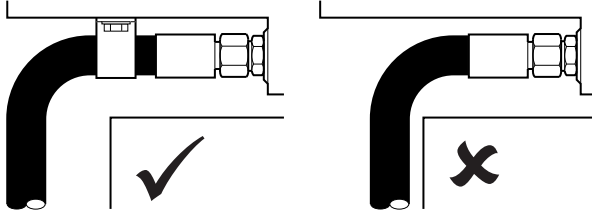

Fig 101.

T037400

- b Make sure that the hose does not touch hot parts. High ambient temperatures can cause the hose to fail.
- c Make sure that the hose does not touch parts which can rub or cause abrasion.
- d Use the hose clamps (where possible) to support long hose runs and keep the hoses away from moving parts, etc.



**Fig 102.**

T037420

To allow for length changes when the hose is pressurised, do not clamp at the bend. The curve absorbs the change.

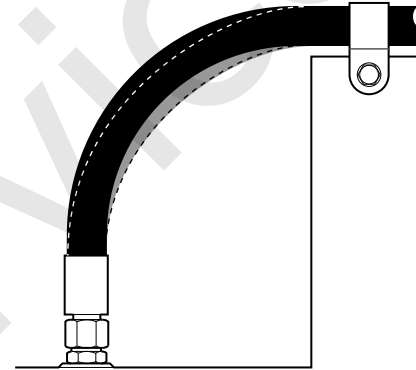

**Fig 103.**

T037410

- 6** Check for leaks.
  - a** Start the engine.
  - b** Operate the related control to increase the pressure in the hydraulic system.

### Connecting/Disconnecting Hydraulic Hoses

- c Stop the engine then remove the starter key.
- d Check for indications of leakage at the hose connections. Correct, as necessary.

### Disconnecting the Hydraulic Hoses

- 1 Make the machine safe. Refer to ***Routine Maintenance, Prepare the Machine for Maintenance.***
- 2 Vent the hydraulic system. Refer to ***Routine Maintenance, Releasing the Hydraulic Pressure.***
- 3 Disconnect the hoses.

If the hoses have quick releases couplings, then refer to ***Quick Release Couplings.***

- 4 Check the hoses and adaptors for damage. Refer to ***Routine Maintenance, Checking for Damage.***
- 5 If necessary, install the blanking caps
- 6 Check for leaks.
  - a Start the engine.



## Optional Attachments

### Connecting/Disconnecting Hydraulic Hoses

- b** Operate the related control to increase the pressure in the hydraulic system.
- c** Stop the engine then remove the starter key.
- d** Check for indications of leakage at the hose connections. Correct, as necessary.

### Connecting/Disconnecting Hydraulic Hoses

Finally, please read the correct fitting and releasing procedures before you install or remove any optional attachment fitted with quick release couplings.

## Quick Release Couplings

### WARNING

**The external surfaces of the couplings must be clean before connecting or disconnecting. Ingress of dirt will cause fluid leaks and difficulty in connecting or disconnecting. You could be killed or seriously injured by faulty Quick Release Couplings.**

2-4-1-15

Flat face quick release couplings allow the operator to remove and install attachments swiftly and efficiently. Generally, your machine pipework will be fitted with a female coupling **A** and a male coupling **B**. The optional attachment hoses will also be fitted with a female coupling **A** and a male coupling **B**. → [Fig 104](#). ( 264).

The quick release couplings should be trouble free and relatively easy to connect and disconnect, provided they are kept clean and used correctly. The recommendations listed below should always apply when using flat face quick release couplings.

### Essential Do's

- Before connecting or removing any hydraulic hose, residual hydraulic pressure trapped in the service hose line must be vented. Make sure the hose service line has been vented before connecting or removing hoses.
- Always wipe the two mating faces clean before connecting.
- Use caps and plugs when the couplings are disconnected.
- Always align the external locking ball (if used) with the notch in the locking sleeve and then pull the locking sleeve back fully to disconnect.
- If a coupling sticks, first check that pressure has been released. Ensure the locking ball and notch in the locking sleeve are aligned, pull back the sleeve and twist the couplings apart. Sticking is normally caused

### Connecting/Disconnecting Hydraulic Hoses

by dirt in the coupling or physical damage due to abuse.

- Connect and disconnect new couplings two or three times to work the PTFE seals. Sometimes a new coupling will stick if the seal has not been worked.
- When fitting couplings, only apply the spanner or grips to the hexagon and nowhere else.
- Avoid damage to the coupling faces. Burrs and scratches cause damage to the seals and cause leaks. They can also impede connection and disconnection of the couplings.
- Periodically lubricate the internal locking balls on the female half of the coupling with silicone grease.

### Essential Don'ts

- Never attempt to reconnect using a damaged half coupling as this will destroy the seals in the mating half and necessitate replacement of both halves.
- Do not leave the coupling where it may be run over by a vehicle or otherwise crushed - this will distort the sleeve and prevent connection and disconnection.
- Never try to turn the sleeve when the coupling is disconnected since this will cause the locking ball to jam under the locking sleeve and damage the coupling.
- Never try to strip the coupling down, there are no user serviceable parts. If the coupling is damaged it should



### Connecting/Disconnecting Hydraulic Hoses

be replaced with a new one. See coupling guides for a reference.

- Never hit the centre poppet of the coupling to try and release locked in pressure. This can cause irreparable damage to the coupling and serious injury.
- When fitting couplings, never clamp on the sleeve of the female or nose of the male - this will cause distortion and/or damage.
- Never subject the couplings to external forces, especially side load. This can reduce the life of the coupling or cause failure.
- Never allow the torsional forces transmitted from hoses to unscrew/screw together couplings.
- Never use a coupling as a plug.
- Do not connect and disconnect with pressure in the line unless the coupling type is specifically designed to do so.

### Connecting Quick Release Couplings

- 1** Remove any residual hydraulic pressure trapped in the service line hose.
- 2** Wipe the two faces of the male and female couplings and make sure they are clean.
- 3** Make sure that ball **C** in the female coupling is located in one of its slots.
- 4** Fit the male coupling into the female coupling.
- 5** Where applicable, rotate sleeve **E** half a turn and make sure that the locking ball **C** does not align with the slot **D**.

### Disconnecting Quick Release Couplings

- 1** Remove any residual hydraulic pressure trapped in the service line hose.
- 2** Where applicable, align the slot **D** with ball **C**.

- 3 Pull back sleeve **E** to release the coupling.

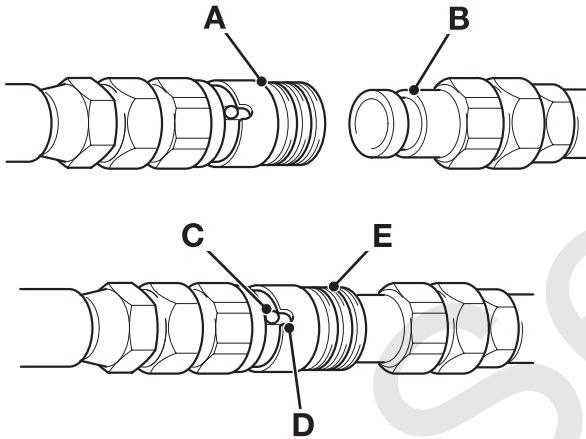

Fig 104.

C007100-1

## Quickhitch Assembly

### Introduction

The Excavator Quickhitch, which is attached to the dipper permits fast removal and installation of the bucket (and other attachments).

The Quickhitch is mechanically operated and does not require hydraulic connections.

#### CAUTION

**When the Quick-Hitch is installed and its attachment fitted, there is a danger of the attachment hitting the underside of the boom. Operate the boom and dipper carefully when the Quick-Hitch and its attachment are fitted.**

2-4-4-2

*Note: To prevent premature wear, failure and breakage, the Quickhitch assembly must be used with a rockbreaker*

*for short periods only. If the machine is to be used for rock breaking for a long period of time, it is recommended that the rockbreaker is installed directly on the machine. When using a rockbreaker, it must be curled towards the machine (as a typical digging operation). Do not use the rockbreaker as a lever as this causes excessive loads on the locking mechanism.*

#### CAUTION

**When the Quickhitch is fitted to the machine, allowance must be made for the weight of the Quickhitch on the rated operating load. The mass of the Quickhitch is stamped on the data plate**

8-4-5-7

## Installation

**Note:** This operation is easier done by two people - one person to operate the controls and one to line up the pivots.

- 1 Before the Quickhitch is installed, make sure that the tipping lever locking bolt assembly is attached with the nut at position **K**. → [Fig 105. \(□ 267\)](#).
- 2 Put the Quickhitch on hard, level ground. Use the safe and correct lifting equipment to move the Quickhitch.
- 3 Position the machine so that the dipper arm and Quickhitch are correctly aligned as shown.
- 4 Engage the dipper:

Operate the controls to line up hole **A** in the dipper arm with the holes **B** in the Quickhitch.

Insert the pivot pin **C** and secure with fasteners **H** and **D**.

- 5 Engage the tipping link:

Operate the controls to line up hole **E** in the tipping link with hole **F** in the Quickhitch.

Insert the pivot pin **G** and secure with fasteners **J** and **K**.

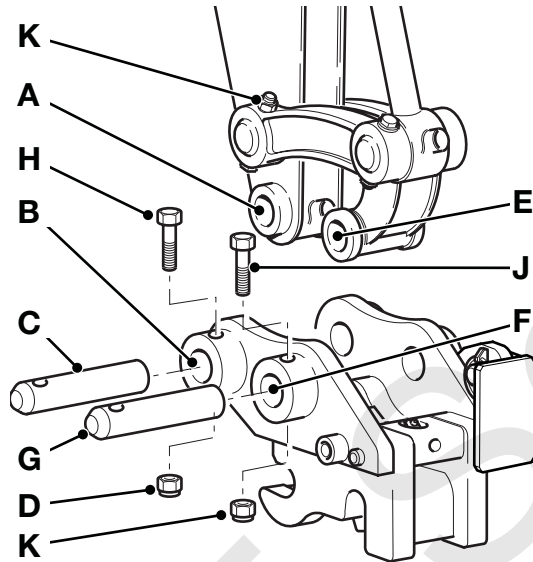

Fig 105.

### Removal

The removal of the Quickhitch is a reversal of the installation procedure. Pay particular attention to safety notices.

### Maintenance

Examine the Quickhitch daily for broken or missing parts.

Remove any debris from the latch hook locking mechanism.

If the Quickhitch is cleaned by high pressure water, always grease the latch hook pivot pin. Always grease the latch hook pin every week.

## Buckets

### Bucket Selection

#### **WARNING**

The bucket selected should be the correct width to suit the hole/trench to be excavated. However, if the hole width demands the larger bucket, consideration should be given to the density/weight of the material to be moved affecting the stability of the machine especially if working on a slope. If there is danger of the machine's stability being compromised, then select a smaller bucket or reposition the machine.

8-2-9-45

#### **CAUTION**

When buckets 750 mm (29.5 in) or wider are fitted to the machine, use extreme caution in operation to avoid contact with the cab.

0122\_1

Use the 300 mm (12 in.) wide bucket for narrow excavations or for maximum penetration when digging in hard, rocky or clay soils.

Larger buckets are ideally suited to bulk shifting light or loose materials.

### Removing a Bucket - Non Quickhitch Models

P11-4002

#### 1 Position the Boom

Slew the boom so that it is straight in front of the machine. Rest the bucket on level ground, with the dipper approximately vertical and the bucket flat to the ground. Block the bucket to prevent its movement.

#### **WARNING**

**Stand clear and to one side of the bucket while you remove the pivot pins. With the pins removed, the bucket could roll over.**

2-2-6-6

#### 2 Detach the Bucket

Remove the lynch pin **A** and the pivot pins **B**.

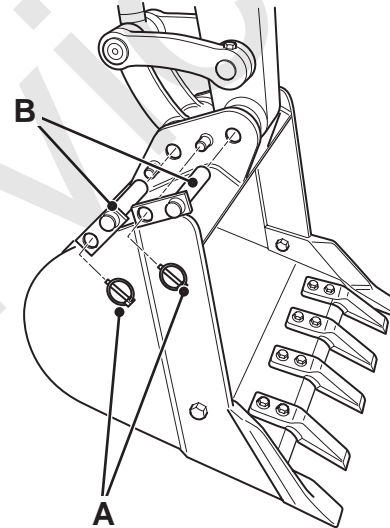

**Fig 106.**



### WARNING

If two people are doing this job make sure that the person working the controls is a competent operator. If the wrong control lever is moved, or if the controls are moved violently, the other person could be killed or injured.

B-2-1-8

#### 3 Withdraw the Dipper

Using the controls, carefully lift the dipper clear of the bucket.



## Installing a Bucket - Non Quickhitch Models

See **Bucket Selection**.

**Note:** This job is easier done by two people - one to operate the controls and one to line up the pivots.

### 1 Position the Bucket

Set the bucket flat on level ground, using a suitable lifting device.

### WARNING

**Do not use your fingers through the holes to align the links.**

8-2-9-32

### 2 Engage the Dipper

If necessary move the machine to align the pivot pin holes. Carefully align the holes in the dipper and

bucket link with the bucket. Fit the pivot pins **B** and lynch pin **A**. → [Fig 106.](#) ( 269)

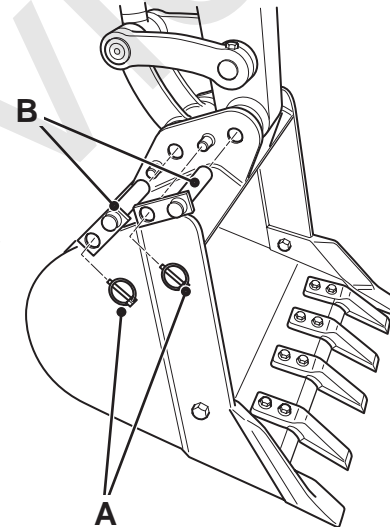

**Fig 107.**

### Removing a Bucket from a Quickhitch

P11-4003

**Note:** Deposit Quickhitch attachments on firm level ground whenever possible. This will make later refitting easy and safe.

- 1 Park the machine on firm level ground.

Position the bucket so that it is approximately 150mm (6 in) above the ground.

#### **WARNING**

**The attachment will roll forward when released. Stand clear and to one side when releasing the attachment.**

2-4-4-1

- 2 Remove lynch pin **A**, and locking pin **B**.
- 3 Insert the tommy bar **C** into the hole **D** of the latch hook.

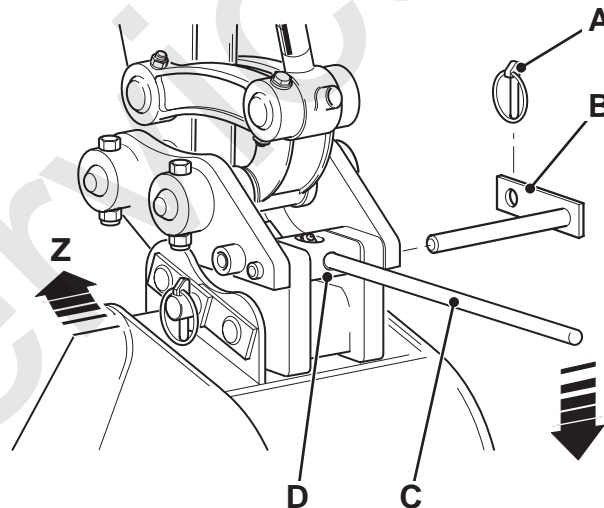

Fig 108.

- 4 Apply a downward pressure on the bar to release the buckets' rear pivot pin from the latch hook, → [Fig 108. \(□ 272\)](#) at Z. Remove the tommy bar from the Quickhitch.
- 5 Rest the bucket on the ground.
- 6 Slowly roll the Quickhitch back and simultaneously raise the dipper arm to release the buckets' front pivot pin, → [Fig 109. \(□ 273\)](#) at Y.

**Note:** Quickhitch procedure applies to most attachments. See your attachments instructions for specific procedures.

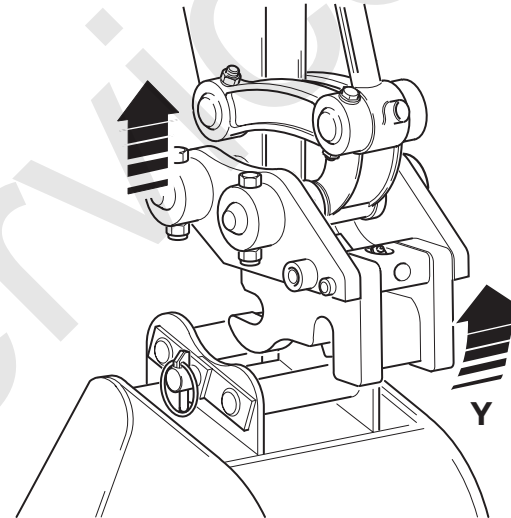

Fig 109.

### Installing a Bucket on a Quickhitch

See **Bucket Selection**.

**1** Position the Bucket

Set the bucket on firm level ground. Use safe and correct lifting equipment to move the bucket.

**2** Position the machine

- a** Position the machine so that the Quickhitch and bucket are correctly aligned for connection as shown.
- b** Use the excavator controls to engage jaw **A** of the Quickhitch with the pivot pin **B** of the bucket.

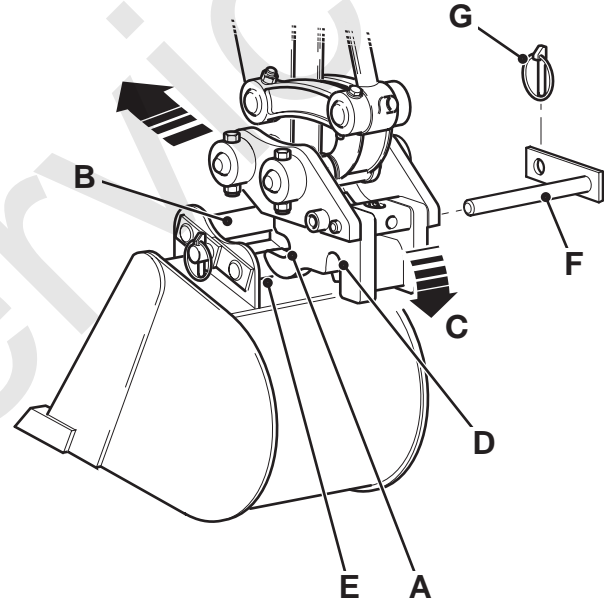

Fig 110.

- c Use the excavator controls to roll the Quickhitch in the direction of arrow **C** until the latch hook **D** has fully engaged the pivot pin **E** on the bucket. Due to the light weight of some bucket it may be necessary to apply a load on the bucket teeth to achieve Quickhitch connection.

Alternatively, use the tommy bar to lever the latch off, allowing the attachment pivot pin **E**, to locate in jaw **D** of the Quickhitch.

### CAUTION

**Make sure that the latch hook has fully engaged.**

2-4-4-3

- d Fit the latch hook locking pin **F** and secure with lynch pin **G**.

### WARNING

**Always fit the Quickhitch latch hook locking pin. Failure to fit the pin will result in possible failure of the latching mechanism. Such a failure would result in the sudden release of an attachment from the machine; you or others could be killed or seriously injured.**

3-4-1-9

### CAUTION

**When the Quick-Hitch is installed and its attachment fitted, there is a danger of the attachment hitting the underside of the boom. Operate the boom and dipper carefully when the Quick-Hitch and its attachment are fitted.**

2-4-4-2

### Replacing Bucket Teeth

P11-4001

- 1 Position the Bucket

Make sure that the bucket is resting flat on the ground

- 2 Switch off the Engine

Remove the starter key.

- 3 Remove a Tooth

Remove the nut and bolt **B** and the tooth **A**.

- 4 Install a Tooth

Position the tooth **A** and fit the bolts **B**.

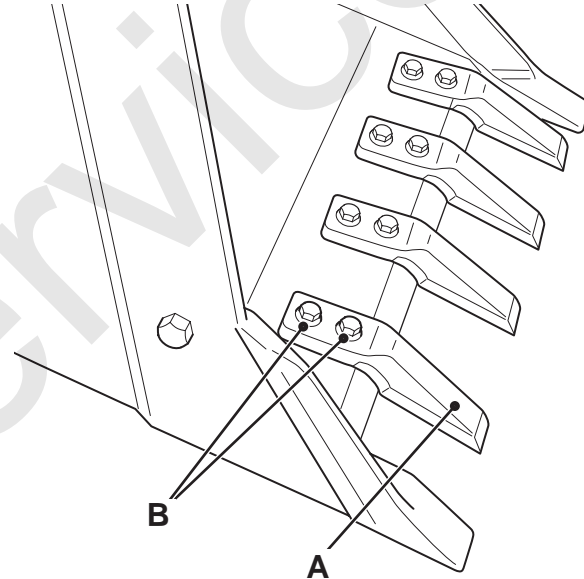

Fig 111.

## Quickhitch Rockbreaker

### Introduction

The standard machine has a single-acting hydraulic circuit for use with the applicable single-acting hydraulic attachments. The attachments that need double-acting hydraulics for example the JCB Augers must have additional (optional) pipework installed, for more information contact your JCB Distributor.

For details of the installation of the attachments refer to the Attachment Handbook, for more information contact your JCB Distributor.

### Removing a Quickhitch Rockbreaker

#### CAUTION

**When the Quick-Hitch is installed and its attachment fitted, there is a danger of the attachment hitting the underside of the boom. Operate the boom and dipper carefully when the Quick-Hitch and its attachment are fitted.**

2-4-4-2

**Note:** *When possible, put the Quickhitch attachments on hard, level ground to make the installation procedure safe and easier.*

- 1 Park the machine on firm, level ground.

#### CAUTION

The rockbreaker must be positioned correctly before attempting to release it from the Quickhitch. If incorrectly positioned, the rockbreaker could swing or fall suddenly from the machine when releasing the Quickhitch latch hook.

8-2-9-36

- 2 Position the breaker just clear of the ground and at an angle such that the breaker does not detach from the front pivot pin when the Quickhitch is unlatched. Typically shown at V. [⇒ Fig 112. \(□ 280\).](#)

#### WARNING

##### Hydraulic Hoses

Damaged hoses can cause fatal accidents. Inspect the hoses regularly. Do not use the machine if a hose or hose fitting is damaged.

INT-3-3-2\_4

#### WARNING

##### Fluid Under Pressure

Fine jets of fluid at high pressure can penetrate the skin. Keep face and hands well clear of fluid under pressure and wear protective glasses and gloves. Hold a piece of cardboard close to suspected leaks and then inspect the cardboard for signs of fluid. If fluid penetrates your skin, get medical help immediately.

INT-3-1-10\_3

- 3 Stop the engine.
- 4 Turn the starter key to the "I" position.
- 5 Operate the auxiliary attachment control pedal, this will release any hydraulic pressure trapped in the system.
- 6 Disconnect the hydraulic hoses.



#### **WARNING**

**The attachment will roll forward when released. Stand clear and to one side when releasing the attachment.**

2-4-4-1

- 7 Remove lynch pin **H**, and locking pin **F**.
- 8 Insert the tommy bar **J** into the hole **K** of the latch hook.
- 9 Apply a downward pressure on the bar to release the breakers rear pivot pin from the latch hook, allowing the breaker to swing forward as shown at **Z**. Remove the tommy bar from the Quickhitch.
- 10 Refit the locking pin **F** and lynch pin **H**. Failure to refit the pin will result in the breaker re-latching as it is lowered to the ground. Make sure that the hydraulic hoses do not become trapped under the breaker.
- 11 Start the engine and carefully lower the breaker to the ground as shown at **Y**.

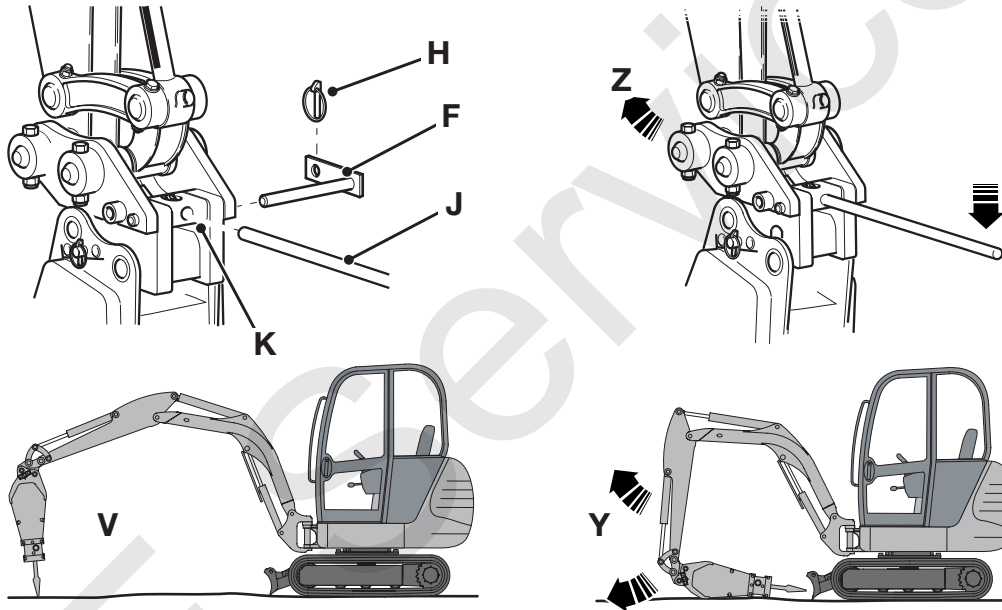

Fig 112.

### Quickhitch Rockbreaker

## Installing a Quickhitch Rockbreaker

### CAUTION

**When the Quick-Hitch is installed and its attachment fitted, there is a danger of the attachment hitting the underside of the boom. Operate the boom and dipper carefully when the Quick-Hitch and its attachment are fitted.**

2-4-4-2

- 1 Position the breaker.

Set the bucket on firm level ground. Use safe and correct lifting equipment to move bucket

- e Position the machine
- f Use the excavator controls to engage the jaw of the Quickhitch with the pivot pin of the breaker.
- g Use the excavator controls to roll the Quickhitch in until the latch hook has fully engaged the pivot pin

on the breaker. It may be necessary to apply a load on the bucket teeth to achieve Quickhitch connection.

Alternatively, use the tommy bar to lever the latch off, allowing the breaker pivot pin to locate in jaw of the Quickhitch.

### CAUTION

**Make sure that the latch hook has fully engaged.**

2-4-4-3

- h Fit the latch hook locking pin and secure with lynch pin.

### Quickhitch Rockbreaker

#### WARNING

Always fit the Quickhitch latch hook locking pin. Failure to fit the pin will result in possible failure of the latching mechanism. Such a failure would result in the sudden release of an attachment from the machine; you or others could be killed or seriously injured.

3-4-1-9

### Operation

#### CAUTION

When the Quick-Hitch is installed and its attachment fitted, there is a danger of the attachment hitting the underside of the boom. Operate the boom and dipper carefully when the Quick-Hitch and its attachment are fitted.

2-4-4-2

The attachment is operated by a floor mounted pedal.

Make sure that the swing/auxiliary switch is set to 'auxiliary'.

The double acting ball valve should be open for single acting attachments and closed for double acting attachments.

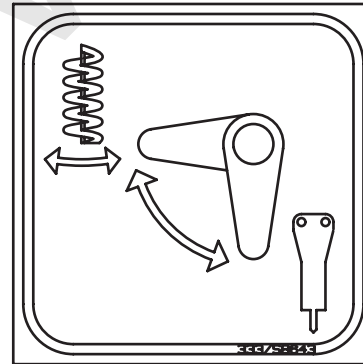

Fig 113.

333/s9643-1

Push the pedal at **A** to operate the single acting attachments. → [Fig 114.](#) ([□ 283](#)).

Push the pedal at **B** to operate the double acting attachments.

The Rockbreaker is a single acting attachment, make sure the ball valve is in the correct position.

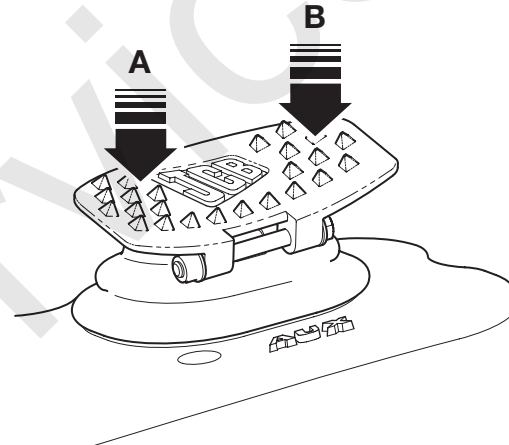

**Fig 114.**



## Optional Attachments

---

Quickhitch Rockbreaker

Page left intentionally blank

# Specifications

## Lifting Regulations and Safe Working Loads

### Introduction

#### Lifting (Object Handling) Regulations

The owner and/or operator must ensure that he fully understands the laws and regulations concerning the use of the JCB Excavator as an earthmover and for lifting. Consult your JCB Distributor for further information.

T2-045

*Note: In certain countries Safety Regulations in force call for the application of specific safety factors. Consult your JCB distributor for information.*

### Safe Working Loads

P11-5001\_3

#### **WARNING**

**The safe working load shown on lifting accessories (for example chains, etc.) is not the safe working load of the machine.**

M0002

The maximum load which may be lifted depends on the equipment fitted to the machine and the laws and regulations in force at the time and in the country in which the machine is being used.

If your machine is equipped to be operated under 'Exemption Certificate' rules, your Exemption Certificate will specify the Safe Working Loads.

### Load Charts

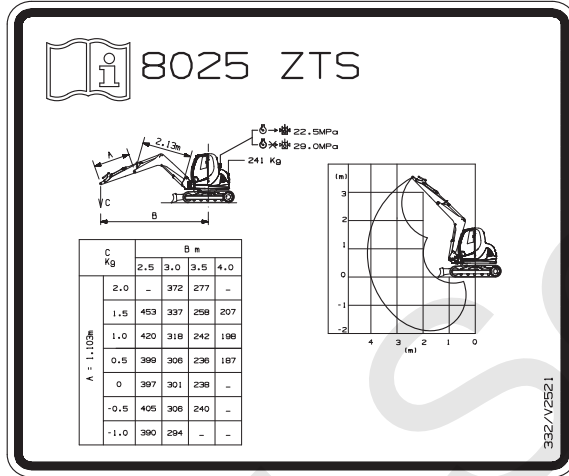

**Fig 115. 8025 ZTS**

332/V2521-2

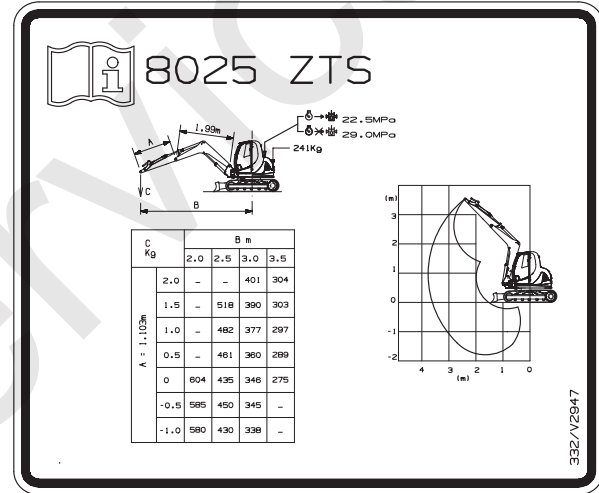

**Fig 116. 8025 ZTS (France)**

332/V2947-2



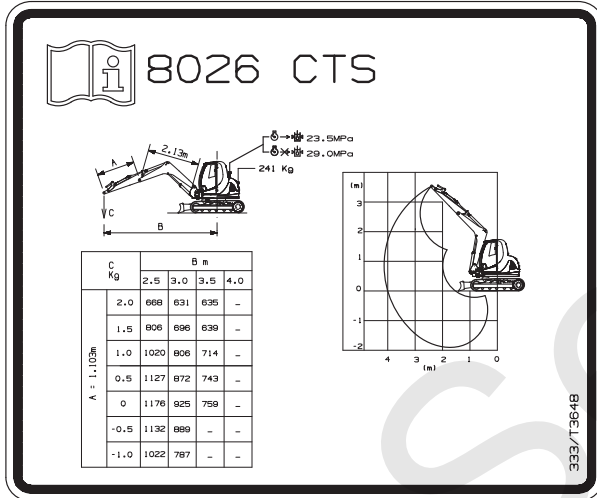

**Fig 117. 8026 CTS**

333/T364B

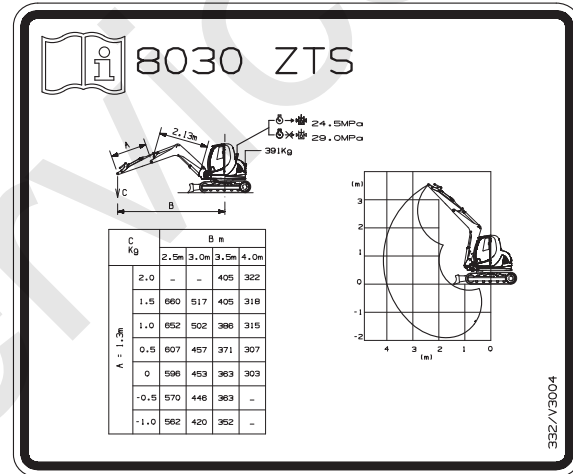

**Fig 118. 8030 ZTS**

332/V3004-2

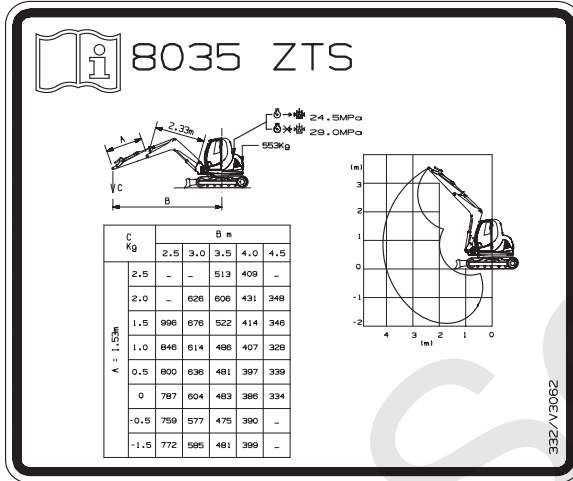

**Fig 119. 8035 ZTS**

332/V3062-2

### Static Dimensions

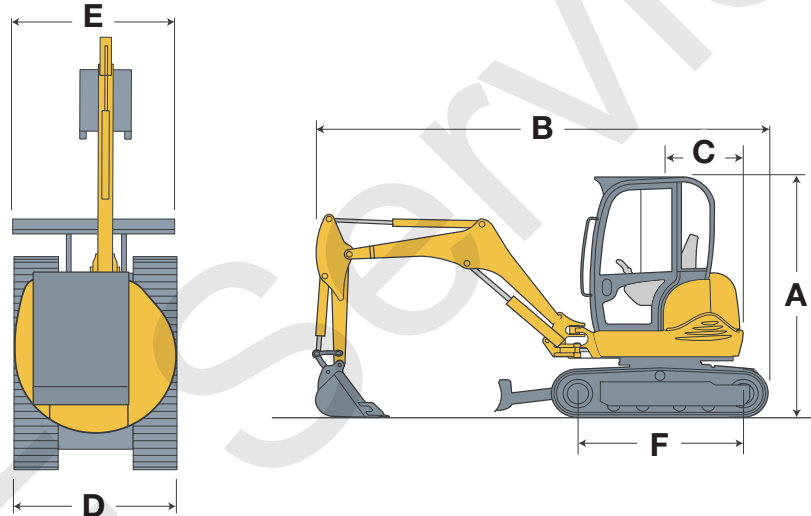

Fig 120.



## Specifications

### Static Dimensions

**Table 5. Machine Dimensions**

		<b>8026 CTS</b>	<b>8025 ZTS</b>	<b>8030 ZTS</b>	<b>8035 ZTS</b>
		<b>mm (ft-in)</b>	<b>mm (ft-in)</b>	<b>mm (ft-in)</b>	<b>mm (ft-in)</b>
<b>A</b>	Overall Height (transport position) <sup>(1)</sup>	2470 (8-1)	2470 (8-1)	2470 (8-1)	2475 (8-2)
<b>B</b>	Overall Length (transport position)	4220 (13 -10)	4280 (14 -0)	4287 (14-0)	4462 (14-8)
<b>C</b>	Tailswing	1225 (4-0)	750 (2-5)	800 (2-7)	850 (2-10)
<b>D</b>	Track Width	1502 (4-11)	1502 (4-11)	1650 (5-5)	1750 (5-9)
<b>E</b>	Superstructure Width	1550 (5-1)	1550 (5-1)	1650 (5-5)	1656 (5-5)
<b>F</b>	Track centres	1440 (4-8)	1440 (4-8)	1597 (5-2)	1707 (5-6)

(1) Does not include truck/trailer height.



## Specifications

### Static Dimensions

**Table 6. Machine Weights**

	<b>8026 CTS</b>	<b>8025 ZTS<sup>(1)</sup></b>	<b>8030 ZTS<sup>(1)</sup></b>	<b>8035 ZTS<sup>(1)</sup></b>
	<b>kg (lb)</b>	<b>kg (lb)</b>	<b>kg (lb)</b>	<b>kg (lb)</b>
Cab				
Steel Tracks	2760 (6085)	2745 (6052)	3277 (7225)	3721 (8186)
Rubber Tracks	2700 (5952)	2685 (5919)	3217 (7092)	3651 (8032)
Canopy				
Steel Tracks	2660 (5864)	2645 (5831)	3177 (7004)	3621 (7966)
Rubber Tracks	2600 (5732)	2585 (5699)	3117 (6872)	3551 (7812)

(1) *Approximate figures with 75 kg (165 lb.) operator and full fuel tank.*

### Performance Dimensions

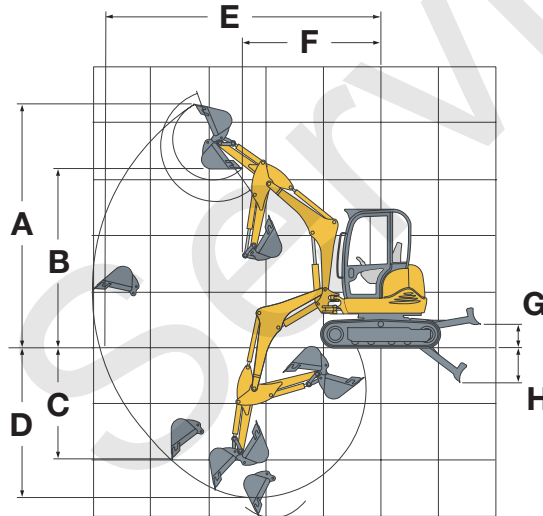

Fig 121.



## Specifications

### Performance Dimensions

Table 7.

		<b>8026 CTS</b>	<b>8025 ZTS</b>	<b>8030 ZTS</b>	<b>8035 ZTS</b>
		<b>mm (ft-in)</b>	<b>mm (ft-in)</b>	<b>mm (ft-in)</b>	<b>mm (ft-in)</b>
<b>A</b>	Max. digging height	4435 (14-6)	4333 (14 -2)	4453 (14-7)	4601 (15 -2)
<b>B</b>	Max. dumping height	3088 (10 -1)	3158 (10 -4)	3205 (10-6)	3482 (11-5)
<b>C</b>	Max. vertical digging depth	1925 (6-3)	1542 (5-1)	1741 (5-8)	2165 (7-1)
<b>D</b>	Max. digging depth <sup>(1)</sup>	2783 (9-0)	2832 (9-3)	3119 (10-3)	3512 (11-6)
<b>E</b>	Max. reach (ground level)	4600 (15 -0)	4828 (15 -10)	5031 (16 -6)	5436 (17-10)
<b>F</b>	Min. boom swing radius	1875 (6-0)	2125 (6-11)	2150 (7-0)	2492 (8-2)
<b>G</b>	Blade cut above ground	275 (0-11)	340 (1-1)	414 (1-4)	413 (1-4)
<b>H</b>	Blade cut below ground	435 (1-4)	398 (1-3)	622 (2-0)	629 (2-1)

(1) Max. dig depth when dozer blade fully lowered.



## Auxiliary Pressures

**Table 8.**

	<b>Auxiliary Flow (L/min.)</b>	<b>Auxiliary Pressure (Bar)</b>
8026 CTS	65	190
8025 ZTS	65	190
8030 ZTS	65	190
8035 ZTS	70	206



### Noise Data

#### Introduction

To assist in compliance with European Directives 2000/14/EC and 2005/88/EC, the noise data values for this type of machine have been provided on the following page(s) and may be used for the assessment of risks to exposure from noise.

The noise data values shown only apply to CE marked machines.

For information relating to this machine when used with other JCB approved attachments, please refer to the literature accompanying the attachments.

T5-008\_2

#### Definition of terms:

**LpA** A-weighted sound pressure level measured at the operator's station.<sup>(1)</sup>

**LwA** Equivalent A-weighted sound power level emitted by the machine.<sup>(2)</sup>

- (1) *Determined in accordance with the test method defined in ISO 6396 and the dynamic test conditions defined on 2000/14/EC.*
- (2) *Guaranteed equivalent sound power (external noise) determined in accordance with the dynamic test conditions defined in 2000/14/EC.*



### All Machines

**Table 9.**

Engine rating <sup>(1)</sup>	Machine	LpA	LwA
18.4kW (23.7Hp)	8026 CTS	77	94
20.9kW (26.8Hp)	8025 ZTS	77	95
20.9kW (26.8Hp)	8030 ZTS	77	95
23.6kW (30.4Hp)	8035 ZTS	77	95

(1) *Nett installed power.*

## Vibration

### Introduction

T5-001

To assist in compliance with European Directive 2002/44/EC, duty specific vibration emission values for this machine type have been provided on the following page(s) and may be used for the assessment of risks to exposure from vibration.

Unless otherwise indicated for a specific operating condition, vibration values are determined with the machine equipped with standard attachments (i.e. bucket, shovel, fork, etc.) for the respective operating condition.

Vibration values are determined from measurements in three perpendicular axes (X, Y and Z). ⇒ [Fig 122.](#) ([□ 297](#)). The highest weighted (rms) value is used to specify the vibration emission.

**Note:** The axis upon which the highest weighted (rms) value occurs is stated on the vibration chart for each of the

Machine Operating Duties, see **Dominant Axis (X, Y or Z)**.

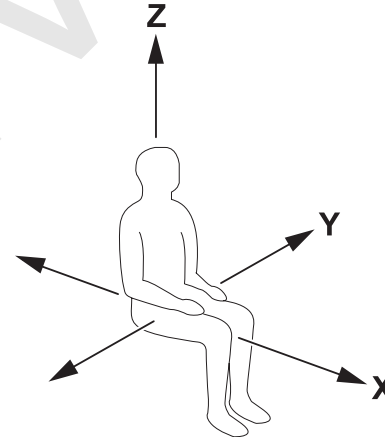

Fig 122.

#### Minimising Exposure to Vibration

Exposure to vibration can be minimised through:

- Selection of the correct size and capacity of machine, equipment and attachments for a particular application.
- Use of a machine equipped with an appropriate seat, keeping the seat maintained and adjusted.
- Checks to ensure that the machine is properly maintained, reporting and correcting any faults.
- Steering, braking, accelerating, shifting gears, moving the attachments and load smoothly.
- Adjusting the machine speed and travel path to minimize the vibration level.
- Keeping the terrain on worksites where the machine is working and travelling in good condition, removing

any large rocks or obstacles and filling in any ditches and holes.

- Choosing routes that avoid rough surfaces and, if this is not possible, drive more slowly to avoid bumping and jolting.
- Travelling over longer distances at an adjusted (medium) speed.
- Avoiding bad postures, i.e. slumping in your seat, constantly leaning forward or sideways or driving with your back twisted.



8026 CTS, 8025 ZTS, 8030 ZTS

Table 10. Whole-Body Vibration Emission Under Representative Operating Conditions  
(According to the Intended Use)  
Dominant Axis (X, Y or Z)





8035 ZTS

Table 11. Whole-Body Vibration Emission Under Representative Operating Conditions  
(According to the Intended Use)  
Dominant Axis (X, Y or Z)

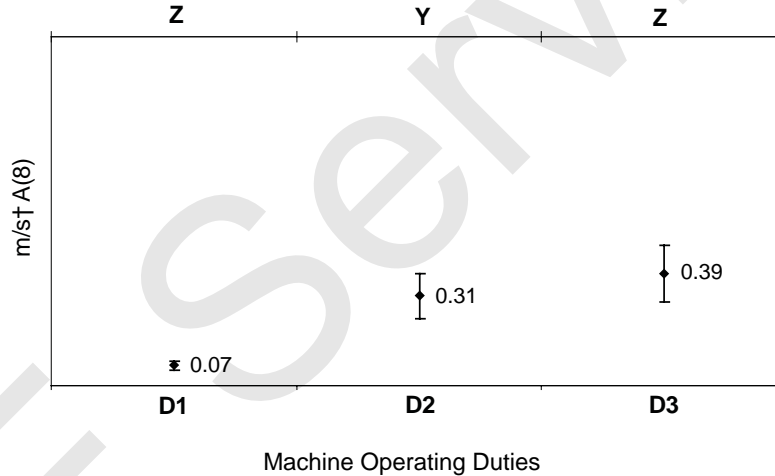



Whole-body vibration emission determined in accordance with ISO 2631-1:1997 for this machine type is 0.08 m/s<sup>2</sup> (8026 CTS, 8025 ZTS and 8030 ZTS) 0.31 m/s<sup>2</sup> (8035Z) normalised to an 8-hour reference period [A(8)] and based upon a test cycle defined in SAE J1166.

Hand-arm vibration determined in accordance with dynamic test conditions defined in ISO 5349-2: 2001 does not exceed 2.5 m/s.

**Note:** *Errors bars are due to variations in vibration emissions due to measurement uncertainty (50% in accordance with EN 12096:1997).*

### Machine Operating Duties

- D1** Low Idle
- D2** Excavating
- D3** Tracking (rough terrain)
- D4** Breaker (8025ZTS, 8030ZTS only)



## Specifications

---

Vibration

Page left intentionally blank





## Warranty Information

Machine Service Record Sheet

# Warranty Information

## Machine Service Record Sheet

<b>Installation Checklist</b>	
Date:	

<b>500 Hrs./6 Month</b>	
Date:	
Hour reading:	

<b>1st 250 Hrs./3 Month</b>	
Date:	
Hour reading:	

<b>1000 Hrs./12 Month</b>	
Annual insurance	
Date:	
Hour reading:	



## Warranty Information

### Machine Service Record Sheet

<b>1500 Hrs./18 Month</b>	
Date:	
Hour reading:	

<b>3000 Hrs./36 Month</b>	
Annual insurance	
Date:	
Hour reading:	

<b>2000 Hrs./24 Month</b>	
Annual insurance	
Date:	
Hour reading:	

<b>3500 Hrs./42 Month</b>	
Date:	
Hour reading:	

<b>2500 Hrs./30 Month</b>	
Date:	
Hour reading:	

<b>4000 Hrs./48 Month</b>	
Annual insurance	
Date:	
Hour reading:	



## Warranty Information

### Machine Service Record Sheet

<b>4500 Hrs./54 Month</b>	
Date:	
Hour reading:	

<b>6000 Hrs./72 Month</b>	
Annual insurance	
Date:	
Hour reading:	

<b>5000 Hrs./60 Month</b>	
Annual insurance	
Date:	
Hour reading:	

<b>6500 Hrs./78 Month</b>	
Date:	
Hour reading:	

<b>5500 Hrs./66 Month</b>	
Date:	
Hour reading:	

<b>7000 Hrs./84 Month</b>	
Annual insurance	
Date:	
Hour reading:	



## Warranty Information

### Machine Service Record Sheet

<b>7500 Hrs./90 Month</b>	
Date:	
Hour reading:	

<b>9000 Hrs./108 Month</b>	
Annual insurance	
Date:	
Hour reading:	

<b>8000 Hrs./96 Month</b>	
Annual insurance	
Date:	
Hour reading:	

<b>9500 Hrs./114 Month</b>	
Date:	
Hour reading:	

<b>8500 Hrs./102 Month</b>	
Date:	
Hour reading:	

<b>10000 Hrs./120 Month</b>	
Annual insurance	
Date:	
Hour reading:	





## Warranty Information

### Registration Information

#### Dealer Copy (2/2)

Registration Date

Installing Engineer

Customer's Name

Address

P.D.I. Date

Owner's Plant Reference No.

Alpha Dot Security System **Yes/No**

Please send details of: 'JCB Assetcare Machinery Protection Plan' **Yes/No**

#### Customer Copy (2/2)

Registration Date

Installing Engineer

**Dealer Copy** (U.K. and Eire only) - Do not send back to JCB Service. A copy of the registration details to be sent direct to:

The Equipment Register Ltd. (T.E.R.)

Bath and West Buildings

Lower Bristol Road

Bath, BA2 3EG

Tel: 01225 464599 (24 Hour)

Fax: 01225 317698

**Customer Copy** - Do not remove this portion from the Operator Manual.



---

# European Community Standards

## EC Declaration of Conformity

### Introduction

TS-007\_3

A completed copy of the EC Declaration of Conformity is supplied with all machines manufactured according to EC type examination and/or self-certification requirements.

A sample copy of the EC Declaration of Conformity and a summary of the information that can appear is provided. Refer to ***Explanation of the EC Declaration of Conformity.***



# European Community Standards

## EC Declaration of Conformity

	
<b>DECLARATION OF CONFORMITY</b>	
NAME AND ADDRESS OF MANUFACTURER:	<input type="text" value="A"/>
HEREBY DECLARES THAT THE MACHINERY / EQUIPMENT DESCRIBED BELOW:	
DESIGNATION OF MACHINERY/EQUIPMENT:	<input type="text" value="P"/>
DESCRIPTION OF MACHINERY / EQUIPMENT:	<input type="text" value="B"/>
TRADE NAME:	JCB
MODEL NAME:	<input type="text" value="C"/>
SERIAL NUMBER OF MACHINERY / EQUIPMENT	<input type="text" value="D"/>
<b>COMPLIES WITH THE PROVISIONS OF THE "MACHINERY DIRECTIVE" (DIRECTIVE 2006/42/EC AS AMENDED).</b> THE FOLLOWING STANDARDS HAVE BEEN USED:	
	<input type="text" value="E"/>
NAME AND ADDRESS OF THE PERSON WHO COMPLES THE TECHNICAL DOCUMENTATION:	<input type="text" value="F"/>
<b>COMPLIES WITH THE PROVISIONS OF THE "ELECTRO-MAGNETIC COMPATIBILITY DIRECTIVE" (DIRECTIVE 2004/108/EC AS AMENDED).</b>	

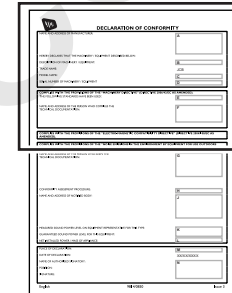
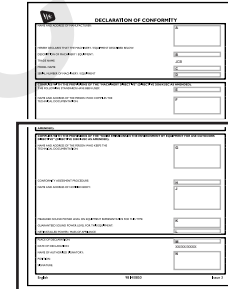

Fig 123. Top Part of Declaration of Conformity

9814-0850-4-GB-A5A



<b>COMPLIES WITH THE PROVISIONS OF THE "NOISE EMISSIONS IN THE ENVIRONMENT BY EQUIPMENT FOR USE OUTDOORS DIRECTIVE" (DIRECTIVE 2000/14/EC AS AMENDED).</b>	
NAME AND ADDRESS OF THE PERSON WHO KEEPS THE TECHNICAL DOCUMENTATION:	<b>G</b> <input style="width: 100%; height: 40px;" type="text"/>
CONFORMITY ASSESSMENT PROCEDURE:	<b>H</b> <input style="width: 100%; height: 20px;" type="text"/>
NAME AND ADDRESS OF NOTIFIED BODY:	<b>J</b> <input style="width: 100%; height: 40px;" type="text"/>
MEASURED SOUND POWER LEVEL ON EQUIPMENT REPRESENTATIVE FOR THIS TYPE:	<b>K</b> <input style="width: 100%; height: 20px;" type="text"/>
GUARANTEED SOUND POWER LEVEL FOR THIS EQUIPMENT:	<b>L</b> <input style="width: 100%; height: 20px;" type="text"/>
NET INSTALLED POWER / MASS OF APPLIANCE:	
PLACE OF DECLARATION:	<b>M</b> <input style="width: 100%; height: 20px;" type="text"/>
DATE OF DECLARATION:	XX/XX/XXXX
NAME OF AUTHORISED SIGNATORY:	<b>N</b> <input style="width: 100%; height: 20px;" type="text"/>
POSITION:	<b>N</b> <input style="width: 100%; height: 20px;" type="text"/>
SIGNATURE:	XXXXXX
English	9814/0850
Issue 4	



**Fig 124. Bottom Part of Declaration of Conformity**

9814-0850-4-GB-A5B



### Explanation of the EC Declaration of Conformity

⇒ [Fig 123. \(□ 310\)](#), ⇒ [Fig 124. \(□ 311\)](#).

- A** JCB Compact Products Limited  
Harewood Estate  
Leek Road  
Cheadle  
Stoke On Trent  
United Kingdom  
ST14 5JP
- B** Excavators, Rope Or Hydraulic (Hydraulic, Tracked, Compact)
- C** Refer to ***Machine Model and Serial Number (Introduction Section)***.

- D** Refer to ***Typical Product Identification Number (PIN) (Introduction Section)***.
- E** EN 474-1:2006+A1:2009  
EN 474-4:2006 +A1:2009
- F** Engineering Manager  
JCB Compact Products Limited  
Harewood Estate  
Leek Road  
Cheadle  
Stoke On Trent  
United Kingdom  
ST14 5JP



## European Community Standards

EC Declaration of Conformity

**G** Mr C J Knowles  
J. C. Bamford Excavators Limited  
Lakeside Works  
Rocester  
Staffordshire  
United Kingdom  
ST14 5JP

**H** ANNEX VI PROCEDURE 1

**J** A. V. Technology  
A. V. House  
Birdhall Lane  
Stockport  
Cheshire  
United Kingdom  
SK3 0XU

**K** Refer to **Noise Data (Specification Section)**.

**L** Refer to **Noise Data (Specification Section)**.

**M** Rocester

**N** Managing Director

**P** Compact excavator



## European Community Standards

---

EC Declaration of Conformity

Page left intentionally blank