



ZTS MINI EXCAVATORS | 8027Z & 8032Z



MAX. ENGINE POWER

20.7kW (27.8hp)

MAX. DIG DEPTH:

3.06 metres (9ft 10in)

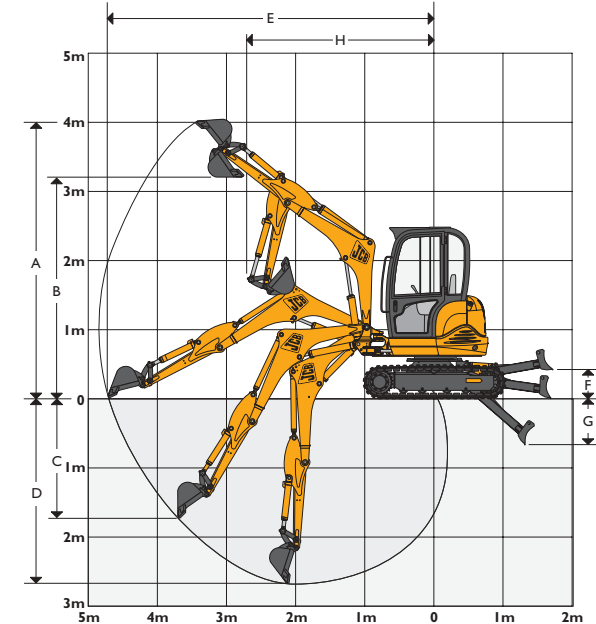
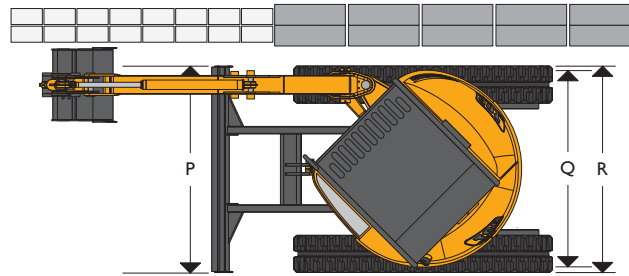
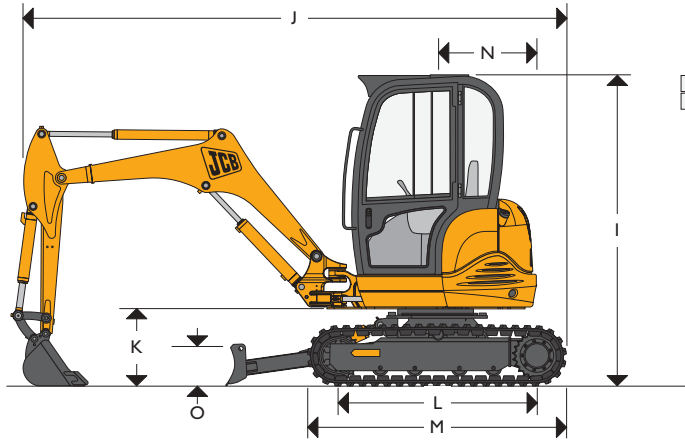

PERFORMANCE AND DIMENSIONS

| Machine model | | 8027Z | 8032Z | |
|------------------------------|------------|--------------|--------------|--------------|
| Dipper | mm (ft-in) | 1100 (3-8) | 1100 (3-8) | 1250 (4-1) |
| A Max dig height | mm (ft-in) | 4264 (13-11) | 4264 (13-11) | 4346 (14-3) |
| B Max dump height | mm (ft-in) | 3107 (10-2) | 3107 (10-2) | 3192 (10-4) |
| C Max vertical dig depth | mm (ft-in) | 1843 (6-1) | 1843 (6-1) | 1973 (6-6) |
| D Max dig depth-dozer up | mm (ft-in) | 2510 (8-3) | 2510 (8-3) | 2646 (8-8) |
| Max dig depth-dozer down | mm (ft-in) | 2876 (9-5) | 2876 (9-5) | 3006 (9-10) |
| E Max ground level reach | mm (ft-in) | 4714 (15-6) | 4714 (15-6) | 4855 (15-11) |
| Bucket rotation | degrees | 194 | 194 | 194 |
| F Dozer cut above ground | mm (ft-in) | 414 (1-4) | 414 (1-4) | 414 (1-4) |
| G Dozer cut below ground | mm (ft-in) | 622 (2-1) | 622 (2-1) | 622 (2-1) |
| H Min. slew radius | mm (ft-in) | 2293 (7-6) | 2293 (7-6) | 2304 (7-7) |
| I Overall height (trans pos) | mm (ft-in) | 2464 (8-1) | 2464 (8-1) | 2464 (8-1) |
| J Overall length (trans pos) | mm (ft-in) | 4426 (14-6) | 4426 (14-6) | 4384 (14-5) |
| K Kingpost clearance | mm (ft-in) | 620 (2-1) | 620 (2-1) | 620 (2-1) |
| L Sprocket/ idler centres | mm (ft-in) | 1585 (5-5) | 1585 (5-5) | 1585 (5-5) |
| M Undercarriage length | mm (ft-in) | 2030 (6-8) | 2030 (6-8) | 2030 (6-8) |

PERFORMANCE AND DIMENSIONS

| Machine model | | 8027Z | 8032Z | |
|----------------------------|------------|--------------|--------------|--------------|
| Dipper | mm (ft-in) | 1100 (3-8) | 1100 (3-8) | 1250 (4-1) |
| N Tailswing | mm (ft-in) | 795 (2-7) | 795 (2-7) | 795 (2-7) |
| O Dozer height | mm (ft-in) | 333 (1-1) | 333 (1-1) | 333 (1-1) |
| P Dozer width | mm (ft-in) | 1650 (5-5) | 1650 (5-5) | 1650 (5-5) |
| Q Superstructure width | mm (ft-in) | 1600 (5-3) | 1600 (5-3) | 1600 (5-3) |
| R Width over tracks | mm (ft-in) | 1600 (5-3) | 1650 (5-5) | 1650 (5-5) |
| Boom swing right | degrees | 45 | 45 | 45 |
| Boom swing left | degrees | 60 | 60 | 60 |
| Max bucket tearout | kN (lbf) | 19.91 (4476) | 23.09 (5191) | 23.09 (5191) |
| Max dipper tearout | kN (lbf) | 16.05 (3608) | 18.62 (4186) | 16.38 (3682) |
| Travel speeds kph 1st gear | kph (mph) | 1.86 (1.16) | 1.86 (1.16) | 1.86 (1.16) |
| Travel speeds kph 2nd gear | kph (mph) | 3.54 (2.2) | 3.54 (2.2) | 3.54 (2.2) |
| Drawbar pull hi | kN (lbf) | 11.82 (2657) | 14.52 (3264) | 14.52 (3264) |
| Drawbar pull low | kN (lbf) | 25.03 (5627) | 31.70 (7126) | 31.70 (7126) |
| Slew speed | rpm | 10.0 | 10.0 | 10.0 |



MACHINE WEIGHTS

| Machine model | | 8027Z | 8032Z |
|--------------------|---------|-------------|-------------|
| Operating weight* | kg (lb) | 2963 (6533) | 3367 (7423) |
| Transport weight | kg (lb) | - 75 (165) | - 75 (165) |
| With steel tracks | kg (lb) | + 30 (66) | + 70 (165) |
| With 1100mm dipper | kg (lb) | 0 | - 6 (13) |
| Canopy | kg (lb) | - 140 (309) | - 140 (309) |

SERVICE CAPACITIES

| Machine model | | 8027Z | 8032Z |
|-----------------------------|--------------|------------|------------|
| Water system capacity - cab | Ltr (US Gal) | 7 (1.85) | 7 (1.85) |
| Canopy | Ltr (US Gal) | 6.5 (1.72) | 6.5 (1.72) |
| Fuel tank capacity | Ltr (US Gal) | 39 (10.30) | 39 (10.30) |
| Engine oil capacity | Ltr (US Gal) | 4.5 (1.19) | 4.5 (1.19) |
| Hydraulic system capacity | Ltr (US Gal) | 70 (15.40) | 70 (15.40) |
| Hydraulic tank capacity | Ltr (US Gal) | 45 (11.89) | 45 (11.89) |

UNDERCARRIAGE

| Machine model | | 8027Z | 8032Z |
|-------------------------|--------------------------|-------------|-------------|
| No of bottom rollers | | 4 | 4 |
| Track width | mm (in) | 250 (10) | 300 (12) |
| Ground bearing pressure | Kg/cm ² (psi) | 0.35 (4.98) | 0.35 (4.98) |
| Ground clearance | mm (in) | 300 (12) | 300 (12) |
| Track tensioning | | Grease | Grease |

HYDRAULICS

| Machine model | | 8027Z | 8032Z |
|-----------------------------|--------------|--------------|--------------|
| Pump | | 2V & 1G | 2V & 1G |
| Nominal output | Lpm | 29/29/26 | 29/29/26 |
| Nominal output | (US gal/m) | 7.7/7.7/6.9 | 7.7/7.7/6.9 |
| Excavator/track main relief | Bar (psi) | 207 (3000) | 240 (3400) |
| Slew main relief | Bar (psi) | 180 (2610) | 180 (2610) |
| Auxiliary hydraulic flow | Ltr (US Gal) | 55 (14.5) | 55 (14.5) |
| Hydraulic motors | | Nachi Piston | Nachi Piston |

*Operating weight to ISO 6016 including cab, rubber tracks, standard dipper, standard dozer, 460mm bucket, full tanks and a 75kg operator.

ENGINE – TIER II COMPLIANT

| Machine model | | 8027Z | 8032Z |
|-----------------------|--------------------|--------------------|--------------------|
| Model | | Perkins 403-15 | Perkins 403-15 |
| Gross power | kW (HP) @ 2200 rpm | 20.7 (27.76) | 20.7 (27.76) |
| Net power | kW (HP) @ 2200 rpm | 19.8 (26.55) | 19.8 (26.55) |
| Gross torque | Nm (lbf ft) | 96 (70.81) | 96 (70.81) |
| Net torque | Nm (lbf ft) | 92 (67.86) | 92 (67.86) |
| Displacement | cc | 1496 | 1496 |
| Fuel injection system | | BOSCH | BOSCH |
| Gradeability | degrees | 35 | 35 |
| Starter motor | kW (HP) | 2 (2.68) | 2 (2.68) |
| Battery | | 12 / 475 amp/hours | 12 / 475 amp/hours |
| Alternator | A/V | 55 / 12 | 55 / 12 |

STANDARD AND OPTIONAL EQUIPMENT

| Machine model | 8027Z | 8032Z | Machine model | 8027Z | 8032Z |
|------------------------------|-------|-------|---------------------------------------------------------|-------|-------|
| TOPS certified canopy | S | S | 1100mm Dipper | S | S |
| TOPS certified cab | O | O | 1250mm Dipper | - | O |
| Full audible systems | S | S | Boom ram protection plate | S | S |
| Lockable toolbox | S | S | Dozer blade | S | S |
| Toolkit | O | O | Hammer pipework | S | S |
| Mobile phone charge point | S | S | Double acting pipework | O | O |
| Coat hook | S | S | Hand held tool circuit | O | O |
| Track lever pedals | S | S | Worklights | O | O |
| Boom work light | S | S | Flashing beacon | O | O |
| Removable lower front screen | S | S | FOGS guard | O | O |
| Up and over window | S | S | 5 General purpose buckets: 230mm (9") to 760mm (30") | O | O |
| Door ajar stay | S | S | 1 Ditching / grading buckets: 1200mm (48") | O | O |
| Slew travel lock | S | S | JCB breakers: | | |
| Lifting points | S | S | HM160Q | O | O |
| Rubber tracks | S | S | Earth drills | O | O |
| Steel tracks | O | O | Mechanical quickhitch | O | O |
| Servo controls | S | S | Fan guard | O | O |
| Dual pattern controls | O | O | Radio cassette | O | O |
| 2 Speed tracking | S | S | | | |
| Suspension seat | S | S | | | |

