



MANITOU NORTH AMERICA, INC.

6401 IMPERIAL DRIVE

WACO, TX 76712-6803

For Parts Orders contact your Manitou North America Dealer or call:
Manitou North America, Inc. Parts Dept. (800) 425-3727 or (254) 799-0232
Parts Dept. Fax (254) 867-6504 Website: www.manitou-na.com

547973AS (11/10)

MT 728 Série C-E2

MT 732 Série C-E2 (USA)

MT 732 Turbo Série C-E2

MT 928 Série C-E2

MT 932 Série C-E2

MT 932 Turbo Série C-E2

MT 1030 S Série 3-E2

MT 1030 S Turbo Série 3-E2

OPERATOR'S MANUAL

THIS OPERATOR'S MANUAL MUST BE KEPT IN THE LIFT TRUCK AND MUST BE READ AND UNDERSTOOD BY OPERATORS.

- INTRODUCTION TO SAFETY

=

- ROUGH TERRAIN FORKLIFT TRUCK

GENERAL SAFETY STANDARDS -----	I
- SAFETY MESSAGES -----	VII
	VII
- SAFETY DECALS -----	I

- TABLE OF CONTENTS -

- OPERATING AND SAFETY INSTRUCTIONS -----	1 - 3
- DESCRIPTION -----	2 - 3
- MAINTENANCE -----	3 - 3
- PICKING UP THE ATTACHMENTS -----	4 - 3

ROUGH TERRAIN FORKLIFT TRUCK
GENERAL SAFETY STANDARDS

ROUGH TERRAIN FORKLIFT TRUCK GENERAL SAFETY STANDARDS

STUDY THE OPERATOR/SERVICE MANUALS

The information in this manual provides general instructions for the safe operation and maintenance of your forklift truck. This information is vital and must be clearly understood by the operator and serviceman. Study this manual and the Rough Terrain Forklift Safety Manual (part no. 422494) thoroughly and carefully before operating or servicing your forklift. Contact your dealer or Manitou North America, Inc. if you have any questions concerning your forklift, its operation, service or parts. Keep both manuals in the literature box on the forklift available for reference. If either manual becomes illegible or is missing, contact your dealer for replacements immediately. This manual cannot cover every situation that might result in an accident. It is the responsibility of the operator to always remain alert for potential hazards and be prepared to avoid them!

ADDITIONAL RECOMMENDED LITERATURE:

ANSI / ITSDF B56.6 is the national consensus standard for rough terrain forklift trucks. It contains rules about forklift safety, maintenance, safe operation, training, and supervision. Forklift owners should learn this standard and make it available for their operators, service personnel, and supervisors. These standards can be obtained, free of charge, from the Industrial Truck Standards Development Foundation (ITSDF) on their web-site at www.itsdf.org. The following references are examples from the standard, addressing forklift operators:

A.) OPERATOR TRAINING QUALIFICATIONS

- 1.) The user shall ensure that operators understand that safe operation is the operator's responsibility. The user shall ensure that operators are knowledgeable of, and observe, all safety rules and practices.
- 2.) Create an effective operator training program centered around user company's policies, operating conditions, and rough terrain forklift trucks. The program should be presented completely to all new operators and not be condensed for those claiming previous experience.
- 3.) Information on operator training is available from several sources, including rough terrain forklift truck manufacturers, users, government agencies, etc.
- 4.) An operator training program should consist of the following:
 - a.) careful selection of the operator, considering physical qualifications, job attitude, and aptitude;
 - b.) emphasis on safety of stock, equipment, operator, and other personnel;
 - c.) citing of rules and why they were formulated;
 - d.) basic fundamentals of rough terrain forklift truck and component design as related to safety, e.g., in.-lb (N-m) loading, mechanical limitations, center of gravity, stability, etc.;
 - e.) introduction to equipment, control locations, and functions. Explain how they work when used properly and problems when used improperly.
 - f.) supervise practice on operating course remote from normal activity and designed to simulate actual operations, e.g., lumber stacking, elevating shingles to the roof, etc.;
 - g.) oral, written, and operational performance tests and evaluations during and at completion of the course;
 - h.) refresher courses, which may be condensed versions of the primary course, and periodic "on job" operator evaluation;
 - i.) understanding of nameplate data and operator instructions and warning information appearing on the rough terrain forklift truck.

B.) GENERAL SAFETY PRACTICES

- 1.) Rough terrain forklift trucks can cause injury if improperly used or maintained.
- 2.) Only authorized operators trained to adhere strictly to all operating instructions shall be permitted to operate rough terrain forklift trucks. Unusual operating conditions may require additional safety precautions, training, and special operating instructions.
- 3.) Modifications and additions which affect capacity or safe operation shall not be performed without the manufacturer's prior written approval. Where such authorization is granted, capacity, operation, and maintenance instruction plates, tags, or decals shall be changed accordingly.
- 4.) If the rough terrain forklift truck is equipped with front end attachment(s) or optional forks, the user shall see that the truck is marked to identify the forks or attachment(s), show the approximate weight of the truck and fork or attachment combination, and show the capacity of the truck with forks or attachment(s) at maximum elevation with load laterally centered.
- 5.) The user shall see that all nameplates and caution and instruction markings are in place and legible. 6.) The user shall consider that changes in load dimension may affect rough terrain forklift truck capacity.

ROUGH TERRAIN FORKLIFT TRUCK GENERAL SAFETY STANDARDS (cont.)

B.) GENERAL SAFETY PRACTICES (cont.)

7.) Where steering can be accomplished with either hand and the steering mechanism is of a type that prevents road reactions from causing the handwheel to spin (power steering or equivalent), steering knobs may be used. When used, steering knobs shall be of a type that can be engaged by the operator's hand from the top and shall be within the periphery of the steering handwheel.

8.) Experience has shown that rough terrain forklift trucks which comply with stability requirements are stable when properly operated. However, improper operation, faulty maintenance, or poor housekeeping may contribute to a condition of instability and defeat the purpose of the requirements.

9.) Users shall give consideration to special operating conditions. The amount of forward and rearward tilt to be used is governed by the application. Although the use of maximum rearward tilt is allowable under certain conditions, such as traveling with the load lowered, the stability of a rough terrain forklift truck as determined by standardized tests does not encompass consideration for excessive tilt at high elevations or the operation of trucks with excessive off-center loads.

10.) Some of the conditions which may affect stability are ground and floor conditions, grade, speed, loading (rough terrain forklift trucks equipped with attachments behave as partially loaded trucks even when operated without a load on the attachment), dynamic and static forces, improper tire inflation, and the judgement exercised by the operator.

C.) OPERATING SAFETY RULES AND PRACTICES

1.) Safe operation is the responsibility of the operator.

2.) This equipment can be dangerous if not used properly. The operator shall develop safe working habits and also be aware of hazardous conditions in order to protect himself, other personnel, the rough terrain forklift truck, and other material.

3.) The operator shall be familiar with the operation and function of all controls and instruments before undertaking to operate the rough terrain forklift truck.

4.) Before operating any rough terrain forklift truck, truck operators shall have read and be familiar with the operator's manual for the particular truck being operated.

5.) Before starting to operate the rough terrain forklift truck: a.) be in operating position and fasten seat belt; b.) place directional controls in neutral; c.) apply brakes; d.) start engine.

6.) Do not start or operate the rough terrain forklift truck, any of its functions, or attachments from any place other than the designated operator's position.

7.) Keep hands and feet inside the operator's designated area or compartment. Do not put any part of the body outside the operator compartment of the rough terrain forklift truck.

8.) Never put any part of the body into the mast structure or between the mast and the rough terrain forklift truck.

9.) Never put any part of the body within the reach mechanism of the rough terrain forklift truck or other attachments.

10.) Understand rough terrain forklift limitations and operate the truck in a safe manner so as not to cause injury to personnel.

11.) Do not allow anyone to stand or pass under the elevated portion of any rough terrain forklift truck, whether empty or loaded.

12.) Do not permit passengers to ride on rough terrain forklift trucks.

13.) Check clearance carefully before driving under electrical lines, bridges, etc.

14.) A rough terrain forklift truck is attended when the operator is less than 25 ft (7.6m) from the truck, which remains in his view.

15.) A rough terrain forklift truck is unattended when the operator is 25ft (7.6m) or more from the truck, which remains in his view, or whenever the operator leaves the truck and it is not in his view.

16.) Before leaving the operator's position:

- a.) bring rough terrain forklift truck to a complete stop; b.) place directional controls in neutral;
- c.) apply the parking brake;
- d.) lower load-engaging means fully, unless supporting an occupied elevated platform; e.) stop the engine;
- f.) if the rough terrain forklift truck must be left on an incline, block the wheels;
- g.) fully lower the load-engaging means.

17.) Maintain a safe distance from the edge of ramps, platforms, and other similar working surfaces. 18.) Do not move railroad cars or trailer with a rough terrain forklift truck.

ROUGH TERRAIN FORKLIFT TRUCK GENERAL SAFETY STANDARDS (cont.)

C.) OPERATING SAFETY RULES AND PRACTICES (cont.)

- 19.) Do not use a rough terrain forklift truck for opening or closing railroad car doors.
- 20.) In areas classified as hazardous, use only rough terrain forklift trucks approved for use in those areas.
- 21.) Report all accidents involving personnel, building structures, and equipment to the supervisor or as directed.
- 22.) Do not add to, or modify, the rough terrain forklift truck.
- 23.) Do not block access to fire aisles, stairways, and fire equipment.
- 24.) For rough terrain forklift trucks equipped with a differential lock, the lock should not be engaged when driving on the road or at high speeds or when turning. If the lock is engaged when turning, there could be loss of steering control.
- 25.) Observe all traffic regulations including authorized speed limits. Under normal traffic conditions, keep to the right, maintain a safe distance, based on speed of travel, from the truck ahead; and keep the truck under control at all times.
- 26.) Yield the right-of-way to pedestrians and emergency vehicles such as ambulances and fire trucks.
- 27.) Do not pass another truck traveling in the same direction at intersections, blind spots, or at other dangerous locations.
- 28.) Slow down and sound the audible warning device(s) at cross-aisles and other locations where vision is obstructed.
- 29.) Cross railroad tracks at an angle wherever possible. Do not park closer than 6 ft (1.8m) to the nearest rail of a railroad track.
- 30.) Keep a clear view of the path of travel and observe other traffic, personnel, and safe clearances.
- 31.) If the load being carried obstructs forward view, travel with the load trailing.
- 32.) Ascend or descend grades slowly and with caution.
 - a.) When ascending or descending grades in excess of 5%, loaded rough terrain forklift trucks should be driven with the load upgrade.
 - b.) Unloaded rough terrain forklift trucks should be operated on all grades with the load-engaging means downgrade.
 - c.) On all grades, the load and load-engaging means shall be tilted back, if applicable, and raised only as far as necessary to clear the road surface.
 - d.) Avoid turning, if possible, and use extreme caution on grades, ramps, or inclines; normally travel straight up or down.
- 33.) Under all travel conditions, operate the rough terrain forklift truck at a speed that will permit it to be brought to a stop in a safe manner.
- 34.) Travel with load-engaging means or load low and, where possible, tilted back. Do not elevate the load except during stacking.
- 35.) Make starts, stops, turns, or direction reversals in a smooth manner so as not to shift load and/or overturn the rough terrain forklift truck.
- 36.) Do not indulge in stunt driving or horseplay.
- 37.) Slow down for wet and slippery surfaces.
- 38.) Before driving over a dockboard or bridge plate, be sure that it is properly secured. Drive carefully and slowly across the dockboard or bridge plate, and never exceed its rated capacity.
- 39.) Do not drive rough terrain forklift trucks onto any elevator unless specifically authorized to do so. Approach elevators slowly, and then enter squarely after the elevator car is properly leveled. Once on the elevator, neutralize the controls, shut off engine, and set brakes. It is advisable that all other personnel leave the elevator before truck is allowed to enter or leave.
- 40.) Avoid running over loose objects on the roadway surface.
- 41.) When negotiating turns, reduce speed to a safe level, and turn steering handwheel in a smooth sweeping motion. Except when maneuvering at a very low speed, turn the steering handwheel at a moderate, even rate.
- 42.) Use special care when traveling without load, as the risk of lateral overturning is greater.
- 43.) Improper use of stabilizer controls (if so equipped) could cause rough terrain forklift truck upset. Always lower the carriage before operating stabilizer controls.
- 44.) For rough terrain forklift trucks equipped with lateral leveling:
 - a.) Always level the frame before raising the boom or mast, with or without a load.
 - b.) Lateral leveling should not be used to position an elevated load; instead, lower the load and reposition the rough terrain forklift truck.
- 45.) Handle only stable or safely arranged loads.
 - a.) When handling off-center loads which cannot be centered, operate with extra caution.
 - b.) Handle only loads within the capacity of the rough terrain forklift truck.
 - c.) Handle loads exceeding the dimensions used to establish rough terrain forklift truck capacity with extra caution. Stability and maneuverability may be adversely affected.

ROUGH TERRAIN FORKLIFT TRUCK GENERAL SAFETY STANDARDS (cont.)

C.) OPERATING SAFETY RULES AND PRACTICES (cont.)

46.) When attachments are used, extra care shall be taken in securing, manipulating, positioning, and transporting the load. Operate rough terrain forklift trucks equipped with attachments as partially loaded trucks when not handling a load.

47.) Completely engage the load with the load-engaging means. Fork length should be at least two-thirds of load length. Where tilt is provided, carefully tilt the load backward to stabilize the load. Caution should be used in tilting backward with high or segmented loads.

48.) Use extreme care when tilting load forward or backward, particularly when high tiering. Do not tilt forward with load-engaging means elevated except to pick up or deposit a load over a rack or stack. When stacking or tiering, use only enough backward tilt to stabilize the load.

49.) The handling of suspended loads by means of a crane arm (boom) or other device can introduce dynamic forces affecting the stability of a rough terrain forklift truck. Grades and sudden starts, stops, and turns can cause the load to swing and create a hazard if not externally stabilized. When handling suspended loads:

- a.) do not exceed the truck manufacturer's capacity of the rough terrain forklift truck as equipped for handling suspended loads.
- b.) only lift the load vertically and never drag it horizontally;
- c.) transport the load with the bottom of the load and the mast as low as possible;
- d.) with load elevated, maneuver the rough terrain forklift truck slowly and cautiously, and only to the extent necessary to permit lowering to the transport position;
- e.) use tag lines to restrain load swing whenever possible.

50.) At the beginning of each shift and before operating the rough terrain forklift truck, check its condition, giving special attention to:

- a.) tires and their inflation pressure
- b.) warning devices
- c.) lights
- d.) lift and tilt systems, load-engaging means, chains, cables, and limit switches
- e.) brakes
- f.) steering mechanism
- g.) fuel system(s)

51.) If the rough terrain forklift truck is found to be in need of repair or in any way unsafe, or if it contributes to an unsafe condition, the matter shall be reported immediately to the user's designated authority, and the truck shall not be operated until it has been restored to safe operating condition.

52.) If during operation the rough terrain forklift truck becomes unsafe in any way, the matter shall be reported immediately to the user's designated authority, and the truck shall not be operated until it has been restored to safe operating condition.

53.) Do not make repairs or adjustments unless specifically authorized to do so.

54.) When refueling, smoking in the area shall not be permitted, the engine shall be stopped, and the operator shall not be on the rough terrain forklift truck.

55.) Spillage of oil or fuel shall be carefully and completely absorbed or evaporated and fuel tank cap replaced before restarting engine.

56.) Do not use open flames when checking electrolyte level in storage batteries, liquid level in fuel tanks, or the condition of LPG fuel lines and connectors.

57.) Do not lift personnel with the forklift. If the forklift must be used to lift people, precautions for the protection of the personnel must be taken (see ITSDF B56.6, chapter 5.15 Elevating Personnel).

ROUGH TERRAIN FORKLIFT TRUCK GENERAL SAFETY STANDARDS (cont.)

D.) SUSPENDED LOADS

A jib or truss boom should ONLY be used to lift and place loads when the machine is stationary and the frame is level. Transporting suspended loads must ALWAYS be done slowly and cautiously, with the boom and load as low as possible. Use taglines to restrict loads from swinging, to avoid overturn.

The handling of suspended loads by means of a truss boom or other similar device can introduce dynamic forces affecting the stability of the machine that are not considered in the stability criteria of industry test standards. Grades and sudden starts, stops and turns can cause the load to swing and create a hazard.

Guidelines for “Free Rigging / Suspended Loads”

1. DO NOT exceed the rated capacity of the telescopic handler as equipped for handling suspended loads. The weight of the rigging must be included as part of the load.
2. During transport, DO NOT raise the load more than 12 inches (305 mm) above the ground, or raise the boom more than 45 degrees.
3. Only lift the load vertically – NEVER drag it horizontally.
4. Use multiple pickup points on the load when possible. Use taglines to restrain the load from swinging and rotating.
5. Start, travel, turn and stop SLOWLY to prevent the load from swinging. DO NOT exceed walking speed.
6. Inspect rigging before use. Rigging must be in good condition and in the U.S. comply with OSHA regulation §1910.184, “Slings,” or §1926.251, “Rigging equipment for material handling.”
7. Rigging equipment attached to the forks must be secured such that it cannot move either sideways or fore and aft. The load center must not exceed 24 inches (610 mm).
8. DO NOT lift the load with anyone on the load, rigging or lift equipment, and NEVER lift the load over personnel.
9. Beware of the wind, which can cause suspended loads to swing, even with taglines.
10. DO NOT attempt to use frame-leveling to compensate for load swing.



WARNING

U.S. OSHA regulations effective November 8, 2010 (29 CFR Part 1926, Subpart CC - Cranes and Derricks in Construction) include requirements for employers that use powered industrial trucks ("forklifts") configured to hoist (by means of a winch or hook) and move suspended loads horizontally. In particular, this regulation applies to any rough-terrain forklift (e.g., "telescopic handler") equipped with a jib or truss boom with a hook (with or without a winch), or a hook assembly attached to the forks. [Note: This regulation is in addition to the OSHA regulation that requires specific forklift operator training: §1910.178(l).]

When a forklift / telescopic handler is configured and used for hoisting, the employer must ensure that:

1. Forklift, lift equipment and rigging have been inspected (each shift, month and year) and are in good, safe condition and properly installed.
2. An operator's manual and applicable load charts are on the forklift.
3. Work zone ground conditions can support the equipment and load. Any hazardous conditions in the work area have been identified, and the operator notified.
4. Equipment is being used within its rated capacity and in accordance with the manufacturer's instructions.

5. Operator and crew members have been trained in the safe use and operation of the equipment, including how to avoid electrocution.
6. During use, no part of the equipment, load line or load will be within the minimum clearance distance specified by OSHA [10 feet (3.0 m), and more for lines rated over 50 kV] of any energized power line, and any taglines used are non-conductive.
7. In addition, for lift equipment with a rated capacity greater than 2000 lbs. (907 kg), the employer must ensure that:
 - a.) An accessible fire extinguisher is on the forklift;
 - b.) Monthly and annual inspections are performed and documented, and records retained (three months for monthly, one year for annual);
 - c.) Before November 10, 2014, operators must have had the additional training and qualification / certification required by OSHA regulations §1926.1427 and §1926.1430.

Note: Refer to the full text of the OSHA crane regulation (29 CFR Part 1926, Subpart CC) for a detailed description

ROUGH TERRAIN FORKLIFT TRUCK GENERAL SAFETY STANDARDS (cont.)

CONCLUSION:

1.) ATTEND OPERATOR TRAINING CLASSES

The forklift operator must clearly understand all instructions concerning the safe operation of the forklift and all safety rules and regulations of the work site. They must have successfully completed a training course in accordance with the Powered Industrial Truck Standard (29 CFR 1910.178) as described by the Occupational Safety and Health Administration (OSHA). They must be qualified as to their visual, hearing, physical, and mental ability to operate the equipment safely. NEVER use drugs or alcohol while operating a forklift! NEVER operate or allow anyone to operate a forklift when mental alertness or coordination is impaired! An operator on prescription or over-the-counter drugs must consult a medical professional regarding any side effects of the medication that may impair their ability to safely operate the forklift.

2.) CREATE A MAINTENANCE PROGRAM

OSHA recommends a maintenance log, listing repairs requested and completed, for each forklift. Also, "lock out tag procedures" should be utilized. If the forklift malfunctions; park it safely, remove the key, tag "Do Not Use", and report the problem to the proper authority or authorized service personnel immediately.

ROUGH TERRAIN FORKLIFT TRUCK GENERAL SAFETY STANDARDS (cont.)

2.) CREATE A MAINTENANCE PROGRAM (cont.)

For the best forklift performance and operation, a maintenance program is required. Use the hour meter on the instrument panel to keep maintenance properly scheduled (see SECTION TWO - "Servicing Schedule"). For repairs on major components (engine, transmission, etc.), contact your nearest dealer for a Repair Manual. Do not operate a forklift that is damaged or does not function properly. Only authorized personnel may make repairs or adjustments to the lift truck. After repairs, the lift truck must be tested for safe operation before returning to service.

3.) FORKLIFT KNOWLEDGE

Forklift trucks can cause serious injury if improperly used or maintained. Study all of the manuals provided for your forklift model. Learn the locations and meanings of all safety decals. If any decals are illegible or missing, have them replaced immediately. Make sure all safety features provided by the original manufacturer are in place and function properly. Do not operate a forklift with damaged, missing or unsafe components. Have it repaired by authorized service personnel. Learn the functions of all controls, gauges, indicator lights, etc. on the forklift. Know the speed/gear ranges, braking and steering capabilities, load ratings and clearances. When referring to the location of forklift components, the terms "left", "right", "front", and "rear" are related to the operator seated normally, facing forward in the operator's seat. If you have any questions about the forklift, consult your supervisor. Failure to fully understand or obey safety warnings can result in serious injury or death!

4.) WORK SITE KNOWLEDGE

Before operating on a work site, learn the rules for movement of people, forklifts and all other traffic. Check the size, weight, and condition of the loads you will be expected to handle. Verify that they are properly secured and safe to transport. Learn where the loads are to be placed, planning your route for a safe approach, watching for hazardous conditions. Will a signal man be required to help place the load? Remove any debris which may cause tire damage or rupture. Plan your route around problem areas or have them corrected. Inform the supervisor of any unsafe conditions observed at the site. Examples of hazards: power lines, cables, low clearance structures, garage doors, telephone pole guide lines, fencing, loose lumber, building materials, drop-offs, trenches, rough/soft spots, oil spills, deep mud, steep inclines, railroad tracks, curbs, etc.. NEVER approach power lines, gas lines or other utilities with the forklift! Always verify that local, state/provincial and federal regulations have been met. Report any accidents involving personnel, building structures, and equipment to the supervisor immediately. Always remain alert - conditions are constantly changing at the work site!

TECHNICAL SUPPORT

All data provided in this manual is subject to production changes, addition of new models, and improved product designs. If a question arises regarding your forklift, please consult your dealer or K-D Manitou, Inc. for the latest information. When ordering service parts or requesting technical information, be prepared to quote the applicable Model/Serial Numbers.

SAFETY MESSAGES

NOTE THE SAFETY ALERT SYMBOL (SHOWN BELOW). IT IDENTIFIES POTENTIAL HAZARDS WHICH, IF NOT AVOIDED MAY RESULT IN INJURY OR DEATH! Also, observe the safety messages places throughout this manual; providing special instructions, telling you when to take precautions and to identify potential hazards. The safety messages are highlighted and outlined in a box similar to those shown in the examples below.

SAFETY ALERT SYMBOL



NOTE or NOTICE

Provides information, special instructions or references about the lift truck.

IMPORTANT

Precautions which must be taken to avoid damage to the lift truck.

CAUTION

Indicates a potentially hazardous situation which, if not avoided, may result in minor or moderate injury. May also alert unsafe practices.

WARNING

Indicates a potentially hazardous situation which, if not avoided, *may result in death or serious injury!*

DANGER

Indicates an imminently hazardous situation which, if not avoided, *will result in death or serious injury.*

CALIFORNIA PROPOSITION 65 WARNING

Diesel Engine Exhaust and some of its constituents are known to the State of California to cause cancer, birth defects or other reproductive harm.

WARNING: Battery posts, terminals and related accessories and related accessories contain lead and lead compounds. **Wash hands after handling.**

SAFETY DECALS

The purpose of this chapter is to introduce you to the safety messages, decals, and nameplates found on your forklift truck. The decals are identified by name, part number, location, and a brief description. (The forklift model logos, and other misc. decals not shown, can be found in your forklift parts manual.) The decals illustrated may not be exactly the same as those installed on your forklift; installation of the decals varies depending on the forklift model, series, decal updates, etc.. The size and location of some decals limit the amount of information that can be placed upon it. For this reason, additional detailed information not found on the decals is provided through-out this manual.

Every decal placed on the lift truck is important; they are constant reminders of safety and instructions that should never be taken for granted. Even experienced operators can be seriously injured or killed by ignoring, refusing to enforce, or forgetting to follow safe operating procedures! Do not assume you know all safe-ty issues concerning the decals. Before operating the lift truck; learn the meaning(s) of the decals as described in this manual. If any decal becomes illegible or missing, have it replaced immediately! Always replace decals using the same decal part no., unless otherwise specified by the manufacturer. For replacement decals not found in your parts manual, contact your nearest dealer. If you have any questions, contact your supervisor or nearest dealer for advice before operating your forklift!

Before Starting - 801011

(Boom equipped models). Location: on the brake fluid cover panel (to the left and below the dash panel).

Safety Instructions - 420792

(Mast equipped models). Location: on or near the operator manual storage case, and/or on the dash panel.

Instructions for the forklift operator; before operating the forklift.

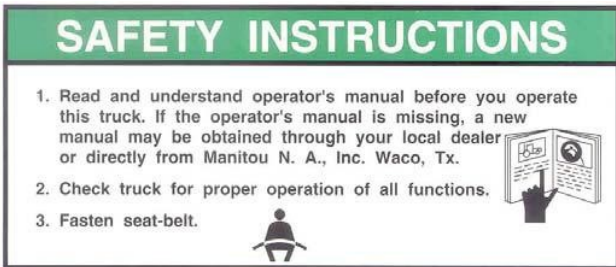

801011

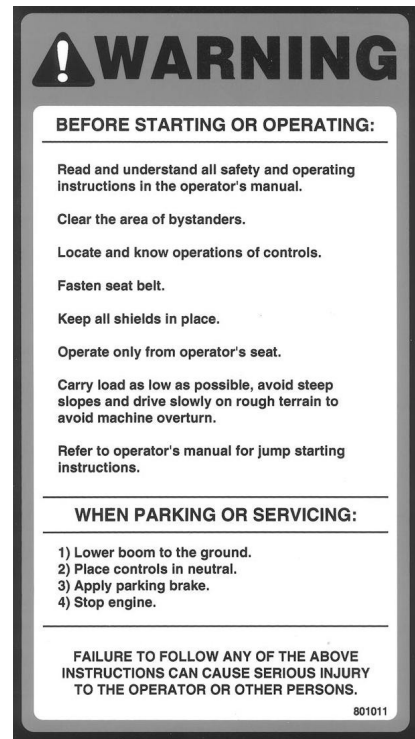

(Boom equipped models). Location: to the right of the operator, near the hydraulic control lever.

Instructs the operator to always wear the seat belt during operations, and never jump from an over-turning forklift.

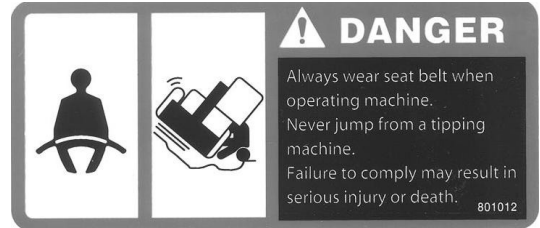

X

SAFETY DECALS

Emergency and Parking Brake - 801010

Location: near the park brake lever.

Identifies the Emergency/Parking Brake Lever.



Alarm Must Sound - 496162

Location: on the dash, in direct view of the operator.

The backup alarm must sound when the forklift is placed in reverse gear.



No Riders - 420732

Location: on the cab entrance(s), and on or near wheel fenders and engine cover.

Informs: riders are not allowed on the forklift.



Clear of Raised Boom - 801006

(Boom equipped models). Location: on both sides of the boom nose.

Keep away from unsupported boom.



Clear of Power Lines - 801007

(Boom equipped models). Location: on both sides of the boom nose.

Keep away from power lines.

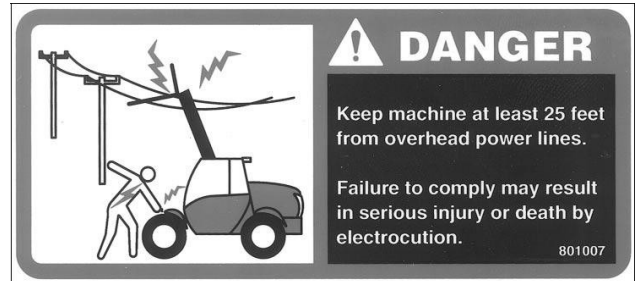

SAFETY DECALS

Use of Frame Leveling - 801013

(Boom equipped models). Location: to the right of the operator near the hydraulic control lever.

Frame leveling notice; load must be lowered.

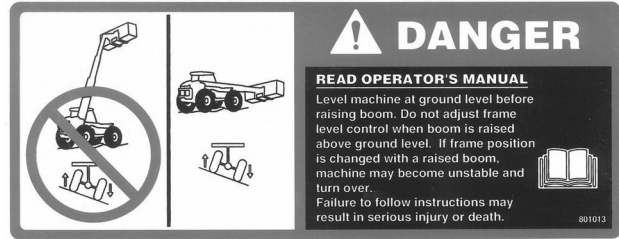

Attachment and Boom Safety - 801009

(Boom equipped models). Location: on both sides of the boom nose.

Important reminders of attachment and boom safety.

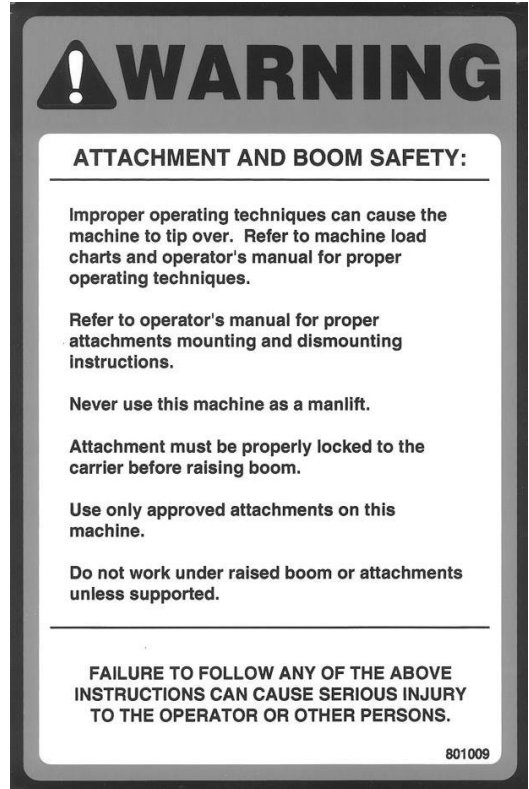

Hydraulic Coupling - 234805

Location: near the quick-disconnect adapters.

Stop the engine and release hydraulic pressure before changing attachments.

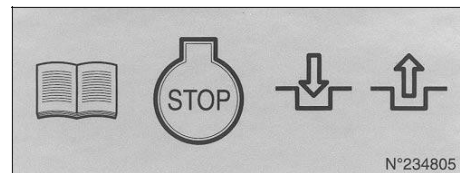

Rotating Fan and Belt(s) - 801008

Location: on the radiator near the fan, and on any fan belt/pulley cover(s).

Keep hands and clothing away from rotating fan and belts.



SAFETY DECALS

Gear Shift Pattern - 33460

(4-speed transmission models). Location: near the gear shift lever.

Identifies the gear shift pattern of the forklift transmission.

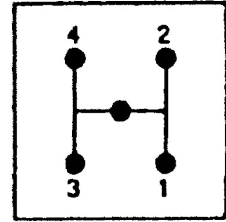

Steering Mode - 184276

(4 wheel steer equipped models). Location: near the steering mode selection lever.

Identifies the steering mode selection.

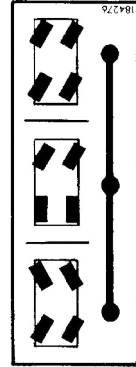

221322

Mineral Oil (Brake Reservoir) - 221322 or 234800 has been replaced by 164091.

Location: near the brake fluid reservoir where applicable.

Refer to the Operator/Service Manual for the correct brake fluid (mineral oil) to be used in the brake system.

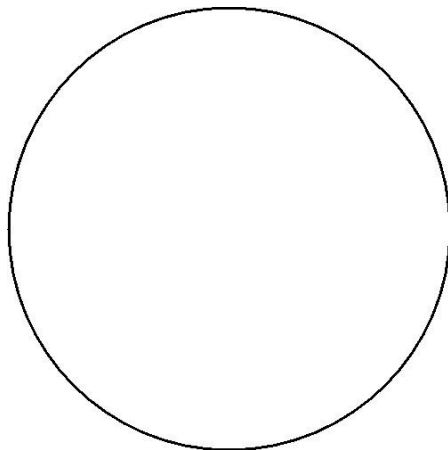

234800

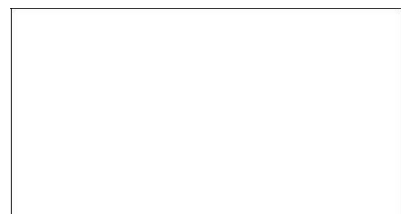

SAFETY DECALS

Hydraulic Oil - 234798 or 76573

Location: on the hydraulic tank or filler cap.

Identifies the hydraulic reservoir (tank) or filler cap.

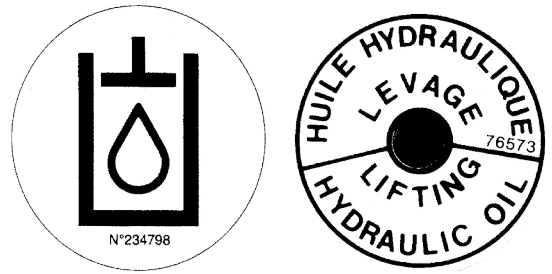

Hydraulic Oil - 61024

Location: on the hydraulic tank.

Identifies the hydraulic reservoir (tank).



Anti-Freeze - 234799

Location: on the radiator, near the radiator filler cap.

Indicates required minimum to maximum anti-freeze protection (-22°F to -40°F).

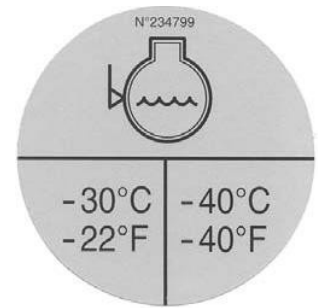

Diesel Fuel - 161101

Location: on the fuel tank, near the filler cap.

Identifies the fuel tank, and use of diesel fuel.



No Step - 496735

Location: varies, depending on the forklift model.

Instructs personnel not to use the designated area as a step.



Do Not Tow - 494918

(Hydrostatic equipped models). Location: on the dash, in view of the operator.

Towing the forklift will damage the transmission; refer to the operator's manual.



SAFETY DECALS

Attachment Warning - 421016

(Boom equipped models). Location: on the boom coupler, near where the retaining shaft is installed.

Reminder to operator; install attachment retaining shaft and safety pin before operations.



Hook Here - 24653

Location: at points provided on the forklift, where straps or chains may be attached to secure the forklift to a trailer during transport.

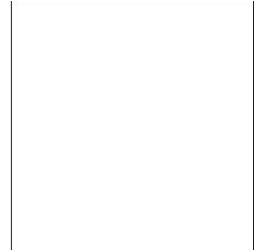

Fork Safety - 426641

(Mast equipped models). Location: on the front and back side of the mast's outer rails, at eye level (4 required).

Instructs personnel not to travel beneath or upon the lift truck forks.

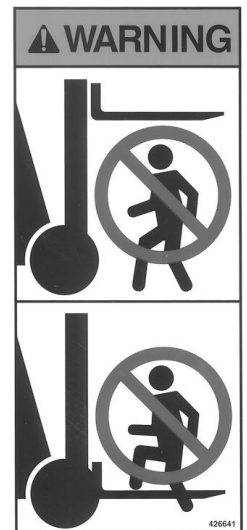

Pinch Point, Large, 2.5 x 4.5 in. - 426643

Pinch Point, Small, 1.5 x 2.75 in. - 426642

(Mast equipped models). Location: on the front and rear sides of the mast cross bracing.

Keep fingers away from the mast crossbracing.

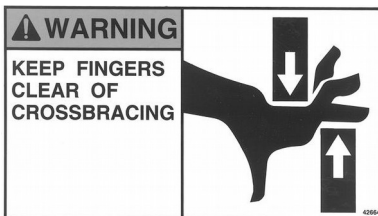

HAND THROTTLE DANGER - 804784

(Boom equipped models, option). Location: Near the hand throttle mechanism.

Reminder to operator; set parking brake before operating hand throttle.

Disengage hand throttle before leaving the forklift.

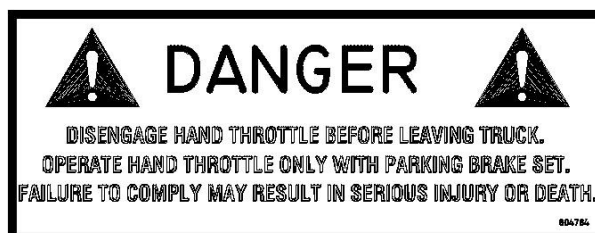

SAFETY DECALS

Acid in Battery - 801014

Location: in or near the battery storage compartment.

Addresses battery hazards.

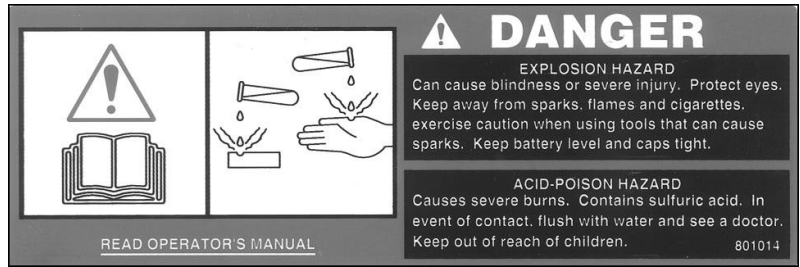

Jump Start Battery - 801015

Location: in or near the battery storage compartment.

Jump start instructions.

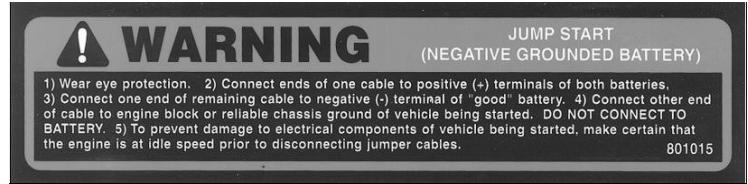

Attachment Plate - 425995

Location: on the optional removeable forklift attachment.

Important manufacturer information about the attachment. Record this information for use when contacting the manufacturer for parts and service.

MANITOU	
MANITOU NORTH AMERICA, INC. 4465 W. FEDERAL DR. WACO, TX 76712 800-425-2994 www.manitou-usa.com	
MODEL NUMBER:	_____
SERIAL NUMBER:	_____
YEAR OF MANUFACTURE:	_____
COUNTRY OF MANUFACTURE:	_____
UNLADEN WEIGHT (LBS.):	_____
CAPACITY (LBS.):	_____
HORIZONTAL CENTER OF GRAVITY (IN):	_____
OPERATING PRESSURE (PSI):	_____
WARNING	
This attachment affects the capacity of the lift truck. Check the operator service manual or load chart for net capacity with this attachment. If the load chart is not available, contact the factory.	
425995	

Overhead Guard Data Plate - B6109

Location: attached to the overhead guard.

Overhead guard conformity.

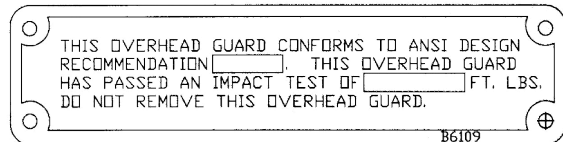

496550

496538

Forklift Data Plate - 496550

(Boom equipped models)

Forklift Data Plate - 496538

(Mast equipped models)

Location: within the operator's compartment.

Important forklift truck identification. Record this information for use when contacting the manufacturer for parts and service.

--	--

1 - OPERATING AND SAFETY INSTRUCTIONS

2 - DESCRIPTION

3 - MAINTENANCE

4 - PICKING UP THE ATTACHMENTS

16/04/2007	1ST DATE OF ISSUE
12/10/2007	UP DATING ADDING : MT 728 Série C-E2 MT 732 Série C-E2 MT 732 Turbo Série C-E2 MT 928 Série C-E2 MT 932 Série C-E2 MT 932 Turbo Série C-E2



1 - OPERATING AND SAFETY INSTRUCTIONS

TABLE OF CONTENTS

INSTRUCTIONS TO THE COMPANY MANAGER 1 - 4

THE OPERATOR	1 - 4
THE LIFT TRUCK	1 - 4
A - THE LIFT TRUCK'S SUITABILITY FOR THE JOB	1 - 4
B - ADAPTATION OF THE LIFT TRUCK TO STANDARD ENVIRONMENTAL CONDITIONS	1 - 4
C - MODIFICATION OF THE LIFT TRUCK	1 - 5
THE INSTRUCTIONS	1 - 5
THE MAINTENANCE	1 - 5

INSTRUCTIONS FOR THE OPERATOR 1 - 6

PREAMBULE	1 - 6
GENERAL INSTRUCTIONS	1 - 6
A - OPERATOR'S MANUAL	1 - 6
B - AUTHORIZATION FOR USE (see current legislation in other countries)	1 - 6
C - MAINTENANCE	1 - 6
D - MODIFICATION OF THE LIFT TRUCK	1 - 6
E - LIFTING PEOPLE	1 - 7
OPERATING INSTRUCTIONS UNLADEN AND LADEN	1 - 8
A - BEFORE STARTING THE LIFT TRUCK	1 - 8
B - DRIVER'S OPERATING INSTRUCTIONS	1 - 8
C - ENVIRONMENT	1 - 9
D - VISIBILITY	1 - 9
E - STARTING THE LIFT TRUCK	1 - 10
F - DRIVING THE LIFT TRUCK	1 - 10
G - STOPPING THE LIFT TRUCK	1 - 11
H - DRIVING THE LIFT TRUCK ON THE PUBLIC HIGHWAY	1 - 12
INSTRUCTIONS FOR HANDLING A LOAD	1 - 14
A - CHOICE OF ATTACHMENTS	1 - 14
B - MASS OF LOAD AND CENTRE OF GRAVITY	1 - 14
C - N/A	1 - 14
D - TRANSVERSE ATTITUDE OF THE LIFT TRUCK	1 - 15
E - TAKING UP A LOAD ON THE GROUND	1 - 15
F - TAKING UP AND LAYING A HIGH LOAD ON TYRES	1 - 16

MAINTENANCE INSTRUCTIONS OF THE LIFT TRUCK 1 - 18

GENERAL INSTRUCTIONS	1 - 18
MAINTENANCE	1 - 18
LUBRICANT AND FUEL LEVELS	1 - 18
HYDRAULIC	1 - 18
ELECTRICITY	1 - 18
WELDING	1 - 19
WASHING THE LIFT TRUCK	1 - 19

IF THE LIFT TRUCK IS NOT TO BE USED FOR A LONG TIME 1 - 20

INTRODUCTION	1 - 20
PREPARING THE LIFT TRUCK	1 - 20
PROTECTING THE I.C. ENGINE	1 - 20
PROTECTING THE LIFT TRUCK	1 - 20
BRINGING THE LIFT TRUCK BACK INTO SERVICE	1 - 21

INSTRUCTIONS TO THE COMPANY MANAGER

THE OPERATOR

-Only qualified, authorized personnel can use the lift truck. This authorization is given in writing by the appropriate person in the establishment with respect to the use of lift trucks and must be carried permanently by the operator.

On the basis of experience, there are a number of possible situations in which operating the lift truck is contra-indicated.



Such foreseeable abnormal uses, the main ones being listed below, are strictly forbidden.

-The foreseeable abnormal behaviour resulting from ordinary neglect, but does not result from any wish to put the machinery to any improper use.

-The reflex reactions of a person in the event of a malfunction, incident, fault, etc. during operation of the lift truck.

-Behaviour resulting from application of the "principle of least action" when performing a task.

-For certain machines, the foreseeable behaviour of such persons as: apprentices, teenagers, handicapped persons, trainees tempted to drive a lift truck, operator tempted to operate a truck to win a bet, in competition or for their own personal experience. The person in charge of the equipment must take these criteria into account when assessing whether or not a person will make a suitable driver.

THE LIFT TRUCK

A - THE TRUCK'S SUITABILITY FOR THE JOB

-MANITOU has ensured that this lift truck is suitable for use under the standard operating conditions defined in this operator's manual, with a STATIC test coefficient of 1.33 and a DYNAMIC test coefficient of 1, as specified in harmonized norm EN 1459 for variable range trucks.

-Before commissioning, the company manager must make sure that the lift truck is appropriate for the work to be done, and perform certain tests (in accordance with current legislation).

B - ADAPTATION OF THE LIFT TRUCK TO STANDARD ENVIRONMENTAL CONDITIONS

-In addition to series equipment mounted on your lift truck, many options are available, such as: road lighting, stop lights, flashing light, reverse lights, reverse buzzer alarm, front light, rear light, light at the jib head, etc.

-The operator must take into account the operating conditions to define the lift truck's signalling and lighting equipment. Contact your dealer.

-Take into account climatic and atmospheric conditions of the site of utilisation.

. Protection against frost (see: 3 - MAINTENANCE: LUBRICANTS AND FUEL).

. Adaptation of lubricants (ask your dealer for information).

. I.C. engine filtration (see: 3 - MAINTENANCE: FILTERS CARTRIDGES AND BELTS).

For operation under average climatic conditions, i.e.: between - 15 °C and + 35 °C, correct levels of lubricants in all the circuits are checked in production. For operation under more severe climatic conditions, before starting up, it is necessary to drain all the circuits,



then ensure correct levels of lubricants using lubricants properly suited to the relevant ambient temperatures. It is the same for the cooling liquid.

-A lift truck operating in an area without fire extinguishing equipment must be equipped with an individual extinguisher. There are solutions, consult your dealer.



Your lift truck is designed for outdoor use under normal atmospheric conditions and indoor use in suitably aerated and ventilated premises. It is prohibited to use the lift truck in areas where there is a risk of fire or which are potentially explosive (e.g. Refineries, fuel or gas depots, stores of inflammable products...). For use in these areas, specific equipment is available (ask your dealer for information).

- Our trucks comply with Directive 89/336/EC concerning electromagnetic compatibility (EMC), and with the corresponding harmonized norm EN 12895. Their proper operation is no longer guaranteed if they are used within areas in which the electromagnetic fields exceed the limit specified by that norm (10 V/m).

-Directive 2002/44/EC requires company managers to not expose their employees to excessive vibration doses. There is no recognized code of measurement for comparing the machines of different manufacturers. The actual doses received can therefore be measured only under actual operating conditions at the user's premises.

-The following are some tips for minimizing these vibration doses:

• Select the most suitable lift truck and attachment for the intended use.

• Adapt the seat adjustment to the operator's weight (according to lift truck model) and maintain it in good condition, as well as the cab suspension. Inflate the tires in accordance with recommendations.

• Ensure that the operators adapt their operating speed to suit the conditions on site.

• As far as possible, arrange the site in such a way as to provide a flat running surface and remove obstacles and harmful potholes.

C - MODIFICATION OF THE LIFT TRUCK

-For your safety and that of others, you must not change the structure and settings of the various components used in your lift truck (hydraulic pressure, calibrating limiters, I.C. engine speed, addition of extra equipment, addition of counterweight, unapproved attachments, alarm systems, etc.) yourself. In this event, the manufacturer cannot be held responsible.

THE INSTRUCTIONS

- The operator's manual must always be in good condition and kept in the place provided on the lift truck and in the language used by the operator.
- The operator's manual and any plates or stickers which are no longer legible or are damaged, must be replaced immediately.

THE MAINTENANCE

-Maintenance or repairs other than those detailed in part: 3 - MAINTENANCE must be carried out by qualified personnel (consult your dealer) and under the necessary safety conditions to maintain the health of the operator and any third party.

 *Your lift truck must be inspected periodically to ensure that it remains in compliance. The frequency of this inspection is defined by current legislation in the country in which the lift truck is used.*

INSTRUCTIONS FOR THE OPERATOR

PREAMBULE

WHENEVER YOU SEE THIS SYMBOL IT MEANS:



WARNING ! BE CAREFUL ! YOUR SAFETY OR THE SAFETY OF THE LIFT TRUCK IS AT RISK.

 *The risk of accident while using, servicing or repairing your lift truck can be restricted if you follow the safety instructions and safety measures detailed in these instruction.*

- Only the operations and manœuvres described in these operator's manual must be performed. The manufacturer cannot predict all possible risky situations. Consequently, the safety instructions given in the operator's manual and on the lift truck itself are not exhaustive.
- At any time, as an operator, you must envisage, within reason, the possible risk to yourself, to others or to the lift truck itself when you use it.

 *Failure to respect the safety and operating instructions, or the instructions for repairing or servicing your lift truck may lead to serious, even fatal accident.*

GENERAL INSTRUCTIONS

A - OPERATOR'S MANUAL

- Read the operator's manual carefully.
- The operator's manual must always be in good condition and in the place provided for it on the lift truck.
- You must report any plates and stickers which are no longer legible or which are damaged.

B - AUTHORIZATION FOR USE

(see current legislation in other countries)

- Only qualified, authorized personnel may use the lift truck. This authorization is given in writing by the appropriate person in the company, in charge of using the lift truck, and must be permanently carried by the operator.
- The operator is not competent to authorise the driving of the lift truck by another person.

C - MAINTENANCE

- The operator must immediately advise his superior if his lift truck is not in good working order or does not comply with the safety notice.
- The operator is prohibited from carrying out any repairs or adjustments himself, unless he has been trained for this purpose. He must keep the lift truck properly cleaned if this is among his responsibilities.
- The operator must carry out daily maintenance (see: 3 - MAINTENANCE: A - DAILY OR EVERY 10 HOURS SERVICE).
- The operator must ensure tyres are adapted to the nature of the ground (see area of the contact surface of the tyres in the chapter: 2 - DESCRIPTION: CHARACTERISTICS). There are optional solutions, consult your dealer.
 - . SAND tyres.
 - . LAND tyres.
 - . Snow chains.

 *Do not use the lift truck if the tyres are incorrectly inflated, damaged or excessively worn, because this could put your own safety or that of others at risk, or cause damage to the lift truck itself. The fitting of foam inflated tyres is prohibited and is not guaranteed by the manufacturer, excepting prior authorisation.*

D - MODIFICATION OF THE LIFT TRUCK

- For your safety and that of others, you must not change the structure and settings of the various components used in your lift truck (hydraulic pressure, calibrating limiters, I.C. engine speed, addition of extra equipment, addition of counterweight, unapproved attachments, alarm systems, etc.) yourself. In this event, the manufacturer cannot be held responsible.

E - LIFTING PEOPLE

- The use of working equipment and/or load lifting attachments to lift people is:strictly forbidden.

OPERATING INSTRUCTIONS UNLADEN AND LADEN

A - BEFORE STARTING THE LIFT TRUCK

- Carry out daily maintenance (see: 3 - MAINTENANCE: A - DAILY OR EVERY 10 HOURS SERVICE).
- Make sure the lights, indicators and windscreen wipers are working properly.
- Make sure the rear view mirrors are in good condition, clean and properly adjusted.
- Make sure the horn works.

B - DRIVER'S OPERATING INSTRUCTIONS

- Whatever his experience, the operator is advised to familiarize himself with the position and operation of all the controls and instruments before operating the lift truck.
- Wear clothes suited for driving the lift truck, avoid loose clothes.
- Make sure you have the appropriate protective equipment for the job to be done.
- Prolonged exposure to high noise levels may cause hearing problems. It is recommended to wear ear muffs to protect against excessive noise.
- Always face the lift truck when getting into and leaving the driving seat and use the handle(s) provided for this purpose. Do not jump out of the seat to get down.
- Always pay attention when using the lift truck. Do not listen to the radio or music using headphones or earphones.
- Never operate the lift truck when hands or feet are wet or soiled with greasy substances.
- For increased comfort, adjust the seat to your requirements and adopt the correct position in the driver's cab.



Under no circumstances must the seat be adjusted while the lift truck is moving.

- The operator must always be in his normal position in the driver's cab. It is prohibited to have arms or legs, or generally any part of the body, protruding from the driver's cab of the lift truck.
- The safety belt must be worn and adjusted to the operator's size.
- The control units must never in any event be used for any other than their intended purposes (e.g. climbing onto or down from the lift truck, portmanteau, etc.).
- If the control components are fitted with a forced operation (lever lock) device, it is forbidden to leave the cab without first putting these controls in neutral.
- It is prohibited to carry passengers either on the lift truck or in the cab.

C - ENVIRONMENT

- Comply with site safety regulations.
- If you have to use the lift truck in a dark area or at night, make sure it is equipped with working lights.
- During handling operations, make sure that no one is in the way of the lift truck and its load.
- Do not allow anybody to come near the working area of the lift truck or pass beneath an elevated load.
- When using the lift truck on a transverse slope, before lifting the jib, follow the instructions given in the paragraph: INSTRUCTIONS FOR HANDLING A LOAD: D - TRANSVERSE ATTITUDE OF THE LIFT TRUCK.
- Travelling on a longitudinal slope:
 - Drive and brake gently.

- Moving without load: Forks or attachment facing downhill.



- Moving with load: Forks or attachment facing uphill.



- Take into account the lift truck's dimensions and its load before trying to negotiate a narrow or low passageway.
- Never move onto a loading platform without having first checked:
 - That it is suitably positioned and made fast.
 - That the unit to which it is connected (wagon, lorry, etc.) will not shift.
 - That this platform is prescribed for the total weight of the lift truck to be loaded.
 - That this platform is prescribed for the size of the lift truck.
- Never move onto a foot bridge, floor or freight lift, without being certain that they are prescribed for the weight and size of the lift truck to be loaded and without having checked that they are in sound working order.
- Be careful in the area of loading bays, trenches, scaffolding, soft land and manholes.
- Make sure the ground is stable and firm under the wheels and/or stabilizers before lifting or removing the load. If necessary, add sufficient wedging under the stabilizers.
- Make sure that the scaffolding, loading platform, pilings or ground is capable of bearing the load.
- Never stack loads on uneven ground, they may tip over.

! *If the load or the attachment must remain above a structure for a long time, there is the risk that it will rest on the structure because of the jib descending owing to the oil in the cylinders cooling down.*

To eliminate this risk:

- Regularly check the distance between the load or the attachment and the structure and readjust this if necessary.
- If possible use the lift truck at an oil temperature as close as possible to ambient temperature.

- In the case of work near aerial lines, ensure that the safety distance is sufficient between the working area of the lift truck and the aerial line.

! *You must consult your local electrical agency. You could be electrocuted or seriously injured if you operate or park the lift truck too close to power cables.*

! *In the event of high winds, do not carry out handling work that jeopardizes the stability of the lift truck and its load, particularly if the load catches the wind badly.*

D - VISIBILITY

- The safety of people within the lift truck's working area, as well as that of the lift truck itself and the operator are depend on good operator visibility of the lift truck's immediate vicinity in all situations and at all times.
- This lift truck has been designed to allow good operator visibility (direct or indirect by means of rear-view mirrors) of the immediate vicinity of the lift truck while traveling with no load and with the jib in the transport position.
- Special precautions must be taken if the size of the load restricts visibility towards the front:
 - moving in reverse,
 - site layout,
 - assisted by a person directing the maneuver (while standing outside the truck's area of travel), making sure to keep this person clearly in view at all times.
 - in any case, avoid reversing over long distances.
- Certain special accessories may require the truck to travel with the jib in the raised position. In such cases, visibility on the right hand side is restricted, and special precautions must be taken:
 - site layout,
 - assisted by a person directing the maneuver (while standing outside the truck's area of travel).
- If visibility of your road is inadequate, ask someone to assist by directing the maneuver (while standing outside the truck's area of travel), making sure to keep this person clearly in view at all times.
- Keep all components affecting visibility in a clean, properly adjusted state and in good working order (e.g. windscreens, windows, windscreen wipers, windscreen washers, driving and work lights, rear-view mirrors).

E - STARTING THE LIFT TRUCK SAFETY NOTICE

 *The lift truck must only be started up or manoeuvred when the operator is sitting in the driver's cab, with his seat belt adjusted and fastened.*

- Never try to start the lift truck by pushing or towing it. Such operation may cause severe damage to the transmission. If necessary, to tow the lift truck in an emergency, the transmission must be placed in the neutral position (see: 3 - MAINTENANCE:

G - OCCASIONAL MAINTENANCE).

- If using an emergency battery for start-up, use a battery with the same characteristics and respect battery polarity when connecting it. Connect at first the positive terminals before the negative terminals.

 *Failure to respect polarity between batteries can cause serious damage to the electrical circuit. The electrolyte in the battery may produce an explosive gas. Avoid flames and generation of sparks close to the batteries. Never disconnect a battery while it is charging.*

INSTRUCTIONS

- Check the closing and locking of the hood(s).

- Make sure that the forward/reverse lever is in neutral.

- Turn the ignition key to the position I to activate the electrical system.

- Make sure the signal lights on the instrument control panel and fuel level indicators are working properly (see: 2 - DESCRIPTION:

INSTRUMENTS AND CONTROLS).

- Turn the ignition key to position II to preheat for 5 seconds and turn the ignition key fully: the I.C. engine should then start. Release the ignition key and let the I.C. engine run at idle.

- Do not engage the starter motor for more than 15 seconds and carry out the preheating for 5 seconds between unsuccessful attempts.

- Make sure all the signal lights on the control instrument panel are off.

- Check all control instruments when the I.C. engine is warm and at regular intervals during use, so as to quickly detect any faults and to be able to correct them without any delay.

- If an instrument does not show the correct display, stop the I.C. engine and immediately carry out the necessary operations.

F - DRIVING THE LIFT TRUCK SAFETY NOTICE

 *Operators' attention is drawn to the risks involved in using the lift truck, in particular:*

- Risk of losing control.

- Risk of losing lateral and frontal stability of the lift truck. The operator must remain in control of the lift truck.

In the event of the lift truck overturning, do not try to leave the cabin during the incident. YOUR BEST PROTECTION IS TO STAY FASTENED IN THE CABIN.

- Observe the company's traffic regulations or, by default, the public highway code.

- Do not carry out operations which exceed the capacities of your lift truck or attachments.

- Always drive the lift truck with the forks or attachment to the transport position, i.e. at 12 in. from the ground, the jib retracted and the carriage sloping backwards.

- Only carry loads which are balanced and properly anchored to avoid any risk of a load falling off.

- Ensure that pallets, cases, etc. are in good order and suitable for the load to be lifted.

- Familiarise yourself with the lift truck on the terrain where it will be used.

- Ensure that the service brakes are working properly.

- The loaded lift truck must not travel at speeds in excess of 8 mph.

- Drive smoothly at an appropriate speed for the operating conditions (land configuration, load on the lift truck).

- Do not use the hydraulic jib controls when the lift truck is moving.

- Do not manoeuvre the lift truck with the jib in the raised position unless under exceptional circumstances and then with extreme caution, at very low speed and using gentle braking. Ensure that visibility is adequate.

- Take bends slowly.

- In all circumstances make sure you are in control of your speed.

- On damp, slippery or uneven terrain, drive slowly.

- Brake gently, never abruptly.

- Only use the lift truck's forward/reverse lever from a stationary position and never do so abruptly.

- Do not drive with your foot on the brake pedal.

- Always remember that hydrostatic type steering is extremely sensitive to movement of the steering wheel, so turn it gently and not jerkily.

- Never leave the I.C. engine on when the lift truck is unattended.

- Do not leave the cab when the lift truck has a raised load.

- Look where you are going and always make sure you have good visibility along the route.

- Use the rear-view mirrors frequently.
- Drive around obstacles.
- Never drive on the edge of a ditch or steep slope.
- It is dangerous to use two lift trucks simultaneously to handle heavy or voluminous loads, since this operation requires particular precautions to be taken. It must only be used exceptionally and after risk analysis.
- The ignition switch has an emergency stop mechanism in case of an operating anomaly occurring in the case of lift trucks not fitted with a punch-operated cut-out.

INSTRUCTIONS

- Always drive the lift truck with the forks or attachment to the transport position, i.e. at 12 in. from the ground, the jib retracted and the carriage sloping backwards.
- For lift trucks with gearboxes, use the recommended gear (see: 2 - DESCRIPTION: INSTRUMENTS AND CONTROLS).
- Select the steering mode appropriate for its use and/or working conditions (see: 2 - DESCRIPTION: INSTRUMENTS AND CONTROLS) (as model of lift truck).
- Release the parking brake.
- Shift the forward/reverse lever to the selected direction of travel and accelerate gradually until the lift truck moves off.

G - STOPPING (PARKING) THE LIFT TRUCK

SAFETY NOTICE

- Never leave the ignition key in the lift truck during the operator's absence.
- When the lift truck is stationary, or if the operator has to leave his cab (even for a moment), place the forks or attachment on the ground, apply the parking brake and put the forward/reverse lever in neutral.
- Make sure that the lift truck is not stopped in any position that will interfere with the traffic flow and at least than 6 feet from the track of a railway.
- In the event of prolonged parking on a site, protect the lift truck from bad weather, particularly from frost (check the level of antifreeze), close and lock all the lift truck accesses (doors, windows, cowls...).

INSTRUCTIONS

- Park the lift truck on flat ground or on an incline of less than 15 %.
- Place the forward/reverse lever in neutral.
- Apply the parking brake.
- For lift trucks with gearboxes, place the gear lever in neutral.
- Retract entirely the jib.
- Lower the forks or attachment to rest on the ground.
- When using an attachment with a grab or jaws, or a bucket with hydraulic opening, close the attachment fully.
- Before stopping the lift truck after a long working period, leave the I.C. engine idling for a few moments, to allow the coolant liquid and oil to lower the temperature of the I.C. engine and transmission. Do not forget this precaution, in the event of frequent stops or warm stalling of the I.C. engine, or else the temperature of certain parts will rise significantly due to the stopping of the cooling system, with the risk of badly damaging such parts.
- Stop the I.C. engine with the ignition switch.
- Remove the ignition key.
- Lock all the accesses to the lift truck (doors, windows, cowls...).

H - DRIVING THE LIFT TRUCK ON THE PUBLIC HIGHWAY

SAFETY INSTRUCTIONS

- Operators driving on the public highway must comply with current highway code legislation.
- The lift truck must comply with current road legislation. If necessary, there are optional solutions. Contact your dealer.

INSTRUCTIONS

- Make sure the revolving light is in place, switch it on and verify its operation.
- Check the good working order and cleanness of lights, indicators and windscreen wiper.
- Switch off the working headlights if the lift truck is fitted with them.
- Select the steering mode "HIGHWAY TRAFFIC" (as model of lift truck) (see: 2 - DESCRIPTION: INSTRUMENTS AND CONTROLS).
- Retract entirely the jib and put the attachment at 12 in. from the ground.
- Place the slope correctors in the central position, i.e. the transverse shaft of the axles parallel to the chassis (as model of lift truck).
- Lift up the stabilizers to the maximum and turn the blocks inwards (as model of lift truck).
- For lift trucks with gearboxes:

On the road, set off in 3rd gear and go into 4th (as model of lift truck) when the conditions and state of the road allow. In hilly areas, set off in 2nd gear and go into 3rd when the conditions and state of the road allow.

 *Never move in neutral (gear reverser or gear lever in neutral or transmission cut-off button pressed) to preserve the lift truck engine brake. Failure to respect this instruction on a slope will lead to excessive speed which may make the lift truck uncontrollable (steering, brakes) and may cause severe mechanical damage.*

DRIVING THE LIFT TRUCK WITH A FRONT-MOUNTED ATTACHMENT

- You must comply with current regulations in your country, covering the possibility of driving on the public highway with a front-mounted attachment on your lift truck.
- If road legislation in your country authorizes circulation with a front-mounted attachment, you must at least:
 - Protect and report any sharp and/or dangerous edges on the attachment (see: 4 - ADAPTABLE ATTACHMENTS IN OPTION ON THE RANGE: ATTACHMENT SHIELDS).
 - The attachment must not be loaded.
 - Make sure that the attachment does not mask the lighting range of the forward lights.
 - Make sure that current legislation in your country does not require other obligations.

OPERATING THE LIFT TRUCK WITH A TRAILER

- For using a trailer, observe the regulations in force in your country (maximum travel speed, braking, maximum weight of trailer, etc.).
- Do not forget to connect the trailer's electrical equipment to that of the lift truck.
- The trailer's braking system must comply with current legislation.
- If pulling a trailer with assisted braking, the tractor lift truck must be equipped with a trailer braking mechanism. In this case, do not forget to connect the trailer braking equipment to the lift truck.
- The maximum vertical pull on the trailer hook must not exceed 3300 ft/lb.
- The authorised maximum train weight must not exceed the maximum weight authorised by the manufacturer (consult the manufacturer's plate on your lift truck).
- For lift trucks with gearboxes:
When driving with a trailer, set off in 2nd gear and go into 3rd when the conditions and state of the road allow. Do not exceed 4th gear to avoid overheating the internal combustion engine and the transmission.

IF NECESSARY, CONSULT YOUR DEALER.

INSTRUCTIONS FOR HANDLING A LOAD

A - CHOICE OF ATTACHMENTS

- Only attachments approved by MANITOU can be used on its lift trucks.
- Make sure the attachment is appropriate for the work to be done (see: 4 - ADAPTABLE ATTACHMENTS IN OPTION ON THE RANGE).
- Make sure the attachment is correctly installed and locked onto the lift truck carriage.
- Make sure that your lift truck attachments work properly.
- Comply with the load chart limits for the lift truck for the attachment used.
- Do not exceed the rated capacity of the attachment.
- Never lift a load in a sling without the attachment provided for the purpose. There are optional solutions ; contact your dealer.



B - MASS OF LOAD AND CENTRE OF GRAVITY

- Before taking up a load, you must know its mass and its centre of gravity.
- The load chart for your lift truck is valid for a load in which the longitudinal position of the centre of gravity is 24 in. from the base of the forks (fig. B1). For a higher centre of gravity, contact your dealer.
- For irregular loads, determine the transverse centre of gravity before any movement (fig. B2) and set it in the longitudinal axis of the lift truck.

 *It is forbidden to move a load heavier than the effective capacity defined on the lift truck load chart.*

For loads with a moving centre of gravity (e.g. liquids), take account of the variations in the centre of gravity in order to determine the load to be handled and be vigilant and take extra care to limit these variations as far as possible.

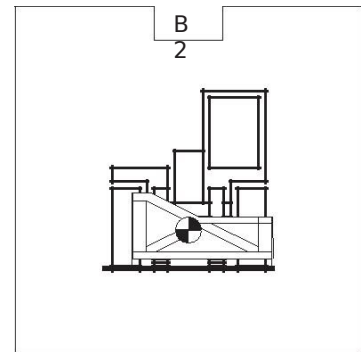
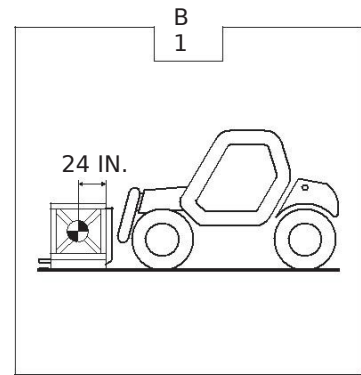

C - N/A

D - TRANSVERSE (HORIZONTAL) ATTITUDE OF THE LIFT TRUCK (depending on the model of lift truck)

The transverse attitude is the transverse slope of the chassis with respect to the horizontal.

Raising the jib reduces the lift truck's lateral stability. The transverse attitude must be set with the jib in down position as follows:

1 - LIFT TRUCK WITHOUT SLOPE CORRECTOR USED ON TYRES

- Position the lift truck so that the bubble in the level is between the two lines (see: 2 - DESCRIPTION: INSTRUMENTS AND CONTROLS).

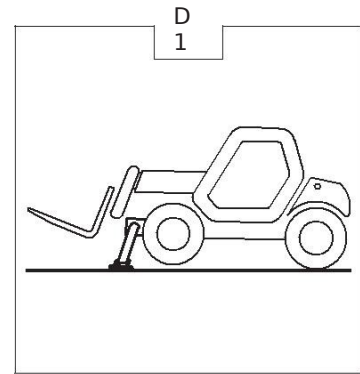

2 - LIFT TRUCK WITH SLOPE CORRECTOR USED ON TYRES

- Correct the slope using the hydraulic control and verify the horizontality via the level. The bubble in the level must be between the two lines (see: 2 - DESCRIPTION: INSTRUMENTS AND CONTROLS).

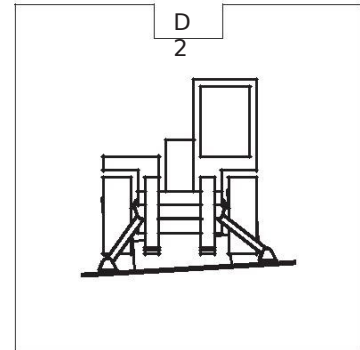

3 - LIFT TRUCK USED ON STABILIZERS

- Set the two stabilizers on the ground and raise the two front wheels of the lift truck (fig. D1).
- Correct the slope using the stabilizers (fig. D2) and make sure the truck is horizontal by checking the level. The bubble of the level must be between the two lines (see: 2 - DESCRIPTION: INSTRUMENTS AND CONTROLS). In this position, the two front wheels must be off the ground.

E - TAKING UP A LOAD ON THE GROUND

- Approach the lift truck perpendicular to the load, with the jib retracted and the forks in a horizontal position (fig. E1).
- Adjust the fork spread and centering in connection with the load (fig. E2) (optional solutions exist, consult your dealer).
- Never lift a load with a single fork.

 Beware of the risks of trapping or squashing limbs when manually adjusting the forks.

- Move the lift truck forward slowly (1) and bring the forks to stop in front of the load (fig. E3), if necessary, slightly lift the jib (2) while taking up the load.
- Bring the load into the transport position.
- Tilt the load far enough backwards to ensure stability (loss of load on braking or going downhill).

FOR A NON-PALLETIZED LOAD

- Tilt the carriage (1) forwards and move the lift truck slowly forwards (2), to insert the fork under the load (fig. E4) (block the load if necessary).
- Continue to move the lift truck forwards (2) tilting the carriage (3) (fig. E4) backwards to position the load on the forks and check the load's longitudinal and lateral stability.

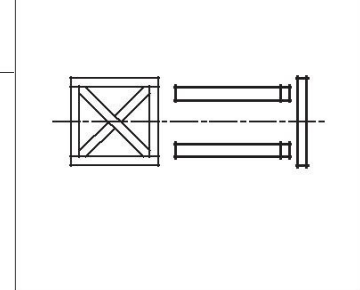
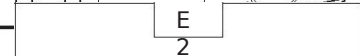
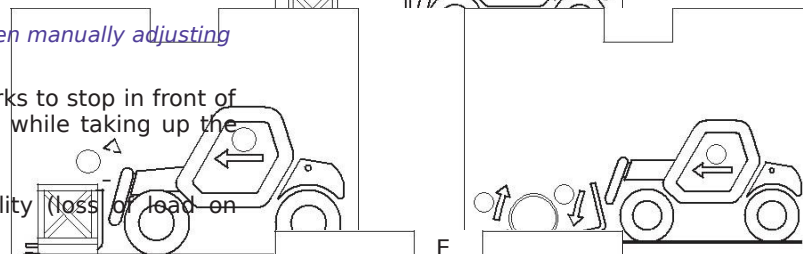
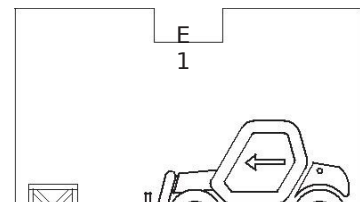

F -
TAKING
UP AND
LAYING
A HIGH
LOAD
ON
TYRES

T
A

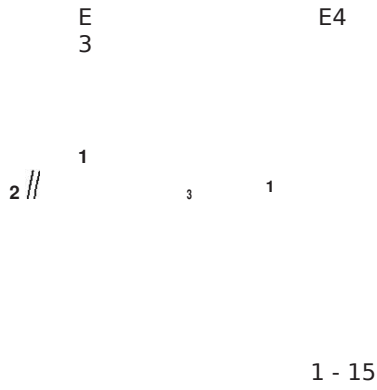

You must not raise the jib if you have not checked the transverse attitude of the lift truck (see :



INSTRUCTION FOR HANDLING A LOAD: D - TRANSVERSE ATTITUDE OF THE LIFT TRUCK).

REMINDER: Make sure that the following operations can be performed with good visibility (see: OPERATIONS INSTRUCTIONS UNLOADING AND LADING: D - VISIBILITY).

HIGH LOAD ON TYRES

- Ensure that the forks will easily pass under the load.
- Lift and extend the jib (1) (2) until the forks are level with the load, moving the lift truck (3) forward if necessary (fig. F1), moving very slowly and carefully.
- Always think about keeping the distance necessary to fit the forks under the load, between the pile and the lift truck (fig. F1) and use the shortest possible length of jib.
- Stop the forks in front of the load by alternately extending and retracting the jib (1) or, if necessary, moving the lift truck forward (2) (fig. F2). Put the handbrake on and set the reverse gear to neutral.
- Slightly lift the load (1) and incline the carriage (2) backwards to stabilize the load (fig. F3).
- Tilt the load sufficiently backwards to ensure its stability.
- Watch the load closely. (If the load is unstable or the lift truck is overloaded, replace the load in the place from which it was taken.)
- If possible lower the load without shifting the lift truck. Lift the jib (1) to release the load, retract (2) and lower the jib (3) to bring the load into the transport position (fig. F4).
- If this is not possible, back up the lift truck (1), manoeuvring very gently and carefully to release the load. Retract (2) and lower the jib (3) to bring the load into the transport position (fig. F5).

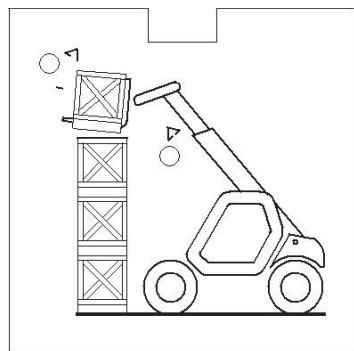
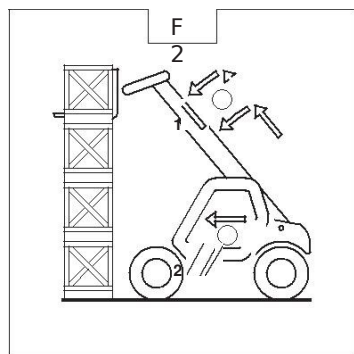
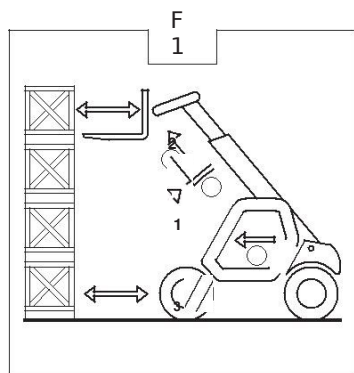

F3

2 //

1 //

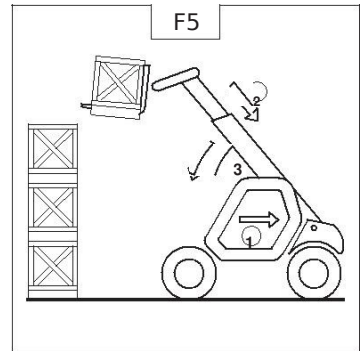
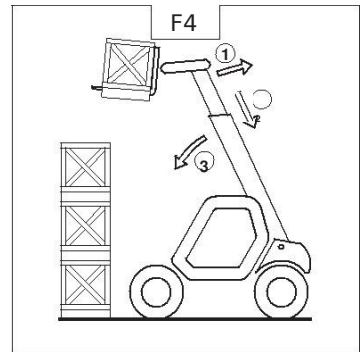

LAYING A HIGH LOAD ON TYRES

- Approach the load in the transport position in front of the pile (fig. F6).

- Put the handbrake on and set the reversing lever to neutral.

- Use the Load Charts to confirm the load and lift height capacities. Lift and extend the jib (1) (2) until the load is above the pile. If necessary, move the lift truck (3) forward (fig. F7), driving very slowly and carefully.

- Place the load in a horizontal position and lay it down on the pile by lowering and retracting the jib (1) (2) in order to position the load correctly (fig. F8).

- If possible, release the fork by alternately retracting and raising the jib (1) (2) (fig. F9). Then set the forks into transport position.

- If this is not possible, reverse the lift truck (1) very slowly and carefully to release the forks (fig. F10). Then set them into transport position.

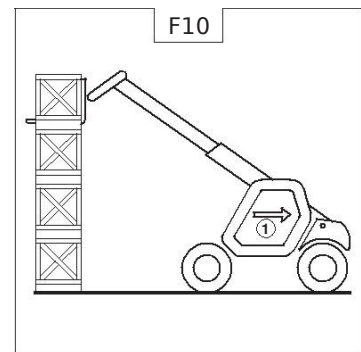
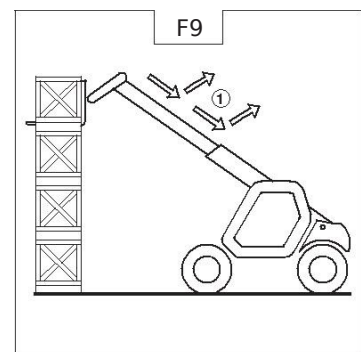
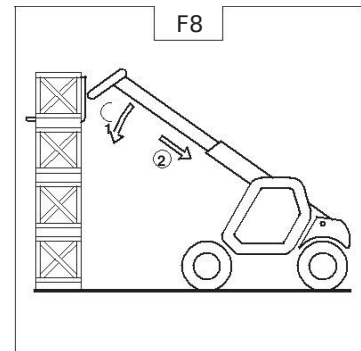
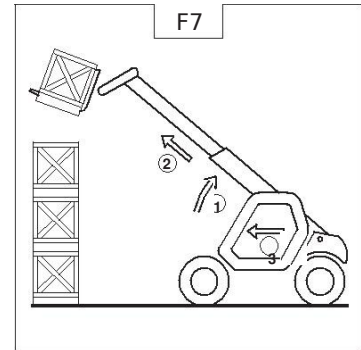
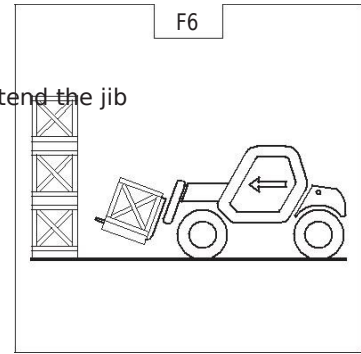

MAINTENANCE INSTRUCTIONS OF THE LIFT TRUCK

GENERAL INSTRUCTIONS

- Ensure the area is sufficiently ventilated before starting the lift truck.
- Wear clothes suitable for the maintenance of the lift truck, avoid wearing jewellery and loose clothes. Tie and protect your hair, if necessary.
- Stop the I.C. engine and remove the ignition key, when an intervention is necessary.
- Read the operator's manual carefully.
- Carry out all repairs immediately, even if the repairs concerned are minor.
- Repair all leaks immediately, even if the leak concerned is minor.
- Make sure that the disposal of process materials and of spare parts is carried out in total safety and in an ecological way.
- Be careful of the risk of burning and splashing (exhaust, radiator, I.C. engine, etc.).

MAINTENANCE

- Perform the periodic service (see: 3 - MAINTENANCE) to keep your lift truck in good working conditions. Failure to perform the periodic service may cancel the contractual guarantee.

LUBRICANT AND FUEL LEVELS

- Use the recommended lubricants (never use contaminated lubricants).
- Do not fill the fuel tank when the I.C. engine is running.
- Only fill up the fuel tank in areas specified for this purpose.
- Do not fill the fuel tank to the maximum level.
- Do not smoke or approach the lift truck with a flame, when the fuel tank is open or is being filled.

HYDRAULIC

- Any work on the load handling hydraulic circuit is forbidden except for the operations described in part: 3 - MAINTENANCE.
- Do not attempt to loosen unions, hoses or any hydraulic component with the circuit under pressure.

 *BALANCING VALVE: For inspection, see: 3 - MAINTENANCE: D - EVERY 500 HOURS SERVICE. It is dangerous to change the setting and remove the balancing valves or safety valves which may be fitted to your lift truck cylinders. These operations must only be performed by approved personnel (consult your dealer).*

 *The HYDRAULIC ACCUMULATORS that may be fitted on your lift truck are pressurised units. Removing these accumulators and their pipework is a dangerous operation and must only be performed by approved personnel (consult your dealer).*

ELECTRICITY

- Do not short-circuit the starter relay to start the IC engine. If the gear reverser is not in neutral and the parking brake is not engaged, the lift truck may suddenly start to move.
- Do not drop metallic items on the battery.
- Disconnect the battery before working on the electrical circuit.

WELDING

- Disconnect the battery before any welding operations on the lift truck.
- When carrying out electric welding work on the lift truck, connect the negative cable from the equipment directly to the part being welded, so as to avoid high tension current passing through the alternator.
- Never carry out welding or work which gives off heat on an assembled tyre. The heat would increase the pressure which could cause the tyre to explode.
- If the lift truck is equipped with an electronic control unit, disconnect this before starting to weld, to avoid the risk of causing irreparable damage to electronic components.

WASHING THE LIFT TRUCK

- Clean the lift truck or at least the area concerned before any intervention.
- Remember to close and lock all accesses to the lift truck (doors, windows, cowls...).
- During washing, avoid the articulations and electrical components and connections.
- If necessary, protect against penetration of water, steam or cleaning agents, components susceptible of being damaged, particularly electrical components and connections and the injection pump.
- Clean the lift truck of any fuel, oil or grease trace.

FOR ANY INTERVENTION OTHER THAN REGULAR MAINTENANCE, CONSULT YOUR DEALER.

IF THE LIFT TRUCK IS NOT TO BE USED FOR A LONG TIME

INTRODUCTION

The following recommendations are intended to prevent the lift truck from being damaged when it is withdrawn from service for an extended period.

For these operations, we recommend the use of approved protective products. Instructions for using the products are given on the packaging.

 *Procedures to follow if the lift truck is not to be used for a long time and for starting it up again afterwards must be performed by your dealership.*

PREPARING THE LIFT TRUCK

- Clean the lift truck thoroughly.
- Check and repair any leakage of fuel, oil, water or air.
- Replace or repair any worn or damaged parts.
- Wash the painted surfaces of the lift truck in clear and cold water and wipe them.
- Touch up the paintwork if necessary.
- Shut down the lift truck (see: OPERATING INSTRUCTIONS UNLADEN AND LADEN).
- Make sure the jib cylinder rods are all in retracted position.
- Release the pressure in the hydraulic circuits.

PROTECTING THE I.C. ENGINE

- Fill the tank with fuel (see: 3 - MAINTENANCE: A - DAILY OR EVERY 10 HOURS SERVICE).
 - Empty and replace the cooling liquid (see: 3 - MAINTENANCE: F - EVERY 2000 HOURS SERVICE).
 - Leave the I.C. engine running at idling speed for a few minutes, then switch off.
 - Replace the I.C. engine oil and oil filter (see: 3 - MAINTENANCE: D - EVERY 500 HOURS SERVICE).
 - Add an approved protective product to the engine oil.
 - Run the I.C. engine for a short time so that the oil and cooling liquid circulate inside.
 - Disconnect the battery and store it in a safe place away from the cold, after charging it to a maximum.
 - Remove the injectors and spray a protective product into each cylinder for two seconds with the piston in low neutral position.
 - Turn the crankshaft once slowly and refit the injectors (see I.C. engine REPAIR MANUAL).
 - Remove the intake hose from the manifold or turbocharger and spray a protective product into the manifold or turbocharger.
 - Cap the intake manifold or turbocharger hole with waterproof adhesive tape.
 - Remove the exhaust pipe and spray a protective product into the exhaust manifold or turbocharger.
 - Refit the exhaust pipe and block the outlet with waterproof adhesive tape.
- NOTE: The spray time is noted on the product packaging and must be increased by 50% for turbo engines.
- Open the filler plug, spray a protective product around the rocker arm shaft and refit the filler plug.
 - Cap the fuel tank using waterproof adhesive tape.
 - Remove the drive belts and store them in a safe place.
 - Disconnect the engine cut-off solenoid on the injection pump and carefully insulate the connection.

PROTECTING THE LIFT TRUCK

- Set the lift truck on axle stands so that the tyres are not in contact with the ground and release the handbrake.
 - Protect cylinder rods which will not be retracted, from corrosion.
 - Wrap the tyres.
- NOTE: If the lift truck is to be stored outdoors, cover it with a waterproof tarpaulin.

BRINGING THE LIFT TRUCK BACK INTO SERVICE

- Remove the waterproof adhesive tape from all the holes.
- Refit the intake hose.
- Refit and reconnect the battery.
- Remove the protection from the cylinder rods.
- Perform the daily service (see: 3 - MAINTENANCE: A - DAILY OR EVERY 10 HOURS SERVICE).
- Put the handbrake on and remove the axle stands.
- Empty and replace the fuel and replace the fuel filter (see: 3 - MAINTENANCE: D - EVERY 500 HOURS SERVICE).
- Refit and set the tension in the drive belts (see: 3 - MAINTENANCE: C - EVERY 250 HOURS SERVICE).
- Turn the I.C. engine using the starter, to allow the oil pressure to rise.
- Reconnect the engine cut-off solenoid.
- Lubricate the lift truck completely (see: 3 - MAINTENANCE: SERVICING SCHEDULE).



Make sure the area is adequately ventilated before starting up the lift truck.

- Start up the lift truck, following the safety instructions and regulations (see: OPERATING INSTRUCTIONS UNLADEN AND LADEN).
- Run all the jib's hydraulic movements, concentrating on the ends of travel for each cylinder.

2 - DESCRIPTION

TABLE OF CONTENTS

<i>IDENTIFICATION OF THE LIFT TRUCK</i>	2 - 4
<i>CHARACTERISTICS</i>	2 - 6
<i>DIMENSIONS AND LOAD CHART</i>	2 - 10
<i>INSTRUMENTS AND CONTROLS</i>	2 - 12
<i>TOWING PIN AND HOOK</i>	2 - 34
<i>DESCRIPTION AND USE OF OPTIONS</i>	2 - 36

IDENTIFICATION OF THE LIFT TRUCK

2 - 4

As our policy is to promote a constant improvement of our products, our range of telescopic lift trucks may undergo certain modifications, without obligation for us to advise our customers.

When you order parts, or when you require any technical information, always specify:

NOTE: For the owner's convenience, it is recommended that a note of these numbers is made in the spaces provided, at the time of the delivery of the lift truck.

PLATE MANUFACTURER OF THE LIFT TRUCK (FIG. A)

- Model _____
- Series _____
- Serial Nr _____
- Chassis Nr _____
- Year of manufacture _____

For any further technical information regarding your lift truck refer to chapter:
2 -
DESCRIPTION: CHARACTERISTICS.

I.C. ENGINE (FIG. B)

- I.C. engine Nr _____

TRANSMISSION (FIG. C)

- Type _____
- MANITOU reference _____
- Serial Nr _____

ANGLE GEAR-BOX (FIG. D)

- Type _____
- MANITOU reference _____
- Serial Nr _____

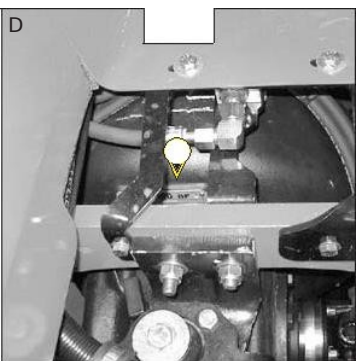
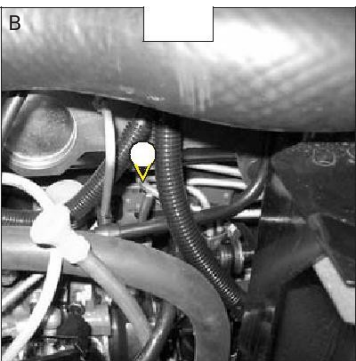
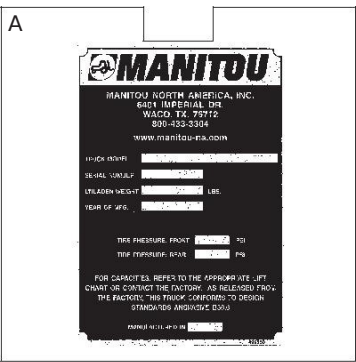

F

E

-T
 y
 -S
 e
 -M
 A

R

-T
 y
 -S
 e
 -M
 A

C

-T
 y
 -S
 e

I

-M
 A
 -D
 a

P

-M
 o
 -S
 e
 -Y
 e

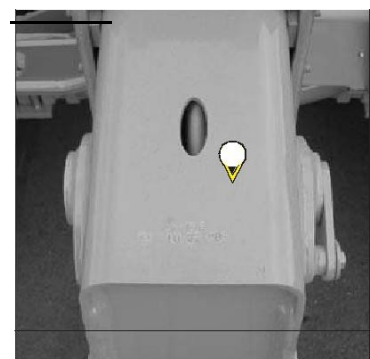

CHARACTERISTICS

ENGINE

- Type	PERKINS	1104C-44T
	1104C-44 RE81372	RG81374
- Number of cylinders	4 in line	4 in line
- Number of strokes	4	4
- Suction	Natural	Turbocharged
- Injection system	Direct	Direct
- Ignition sequence	1.3.4.2.	1.3.4.2
- Clearance of rocker valve (cold)		
. Inlet	0,20 mm	0,20 mm
. Exhaust	0,45 mm	0,45 mm
- Capacity	4400 cm ³	4400 cm ³
- Bore	105 mm	105 mm
- Stroke	127 mm	127 mm
- Compression ratio	19,3/1	17,5/1
- Nominal rating loaded	2200 rpm	2200 rpm
- Rating slow unladen	930 + ²⁰ rpm	930 + ²⁰ rpm
- Max. rating unladen	2400 rpm	2350 rpm
- Power ISO/TR 14396	84 cv/61,5 kw	101 cv/74,5 kw
		412 Nm à 1400
- Maximum torque ISO/TR 14396	302 Nm à 1400 rpm	rpm
- Air cleaner	Sec 3 µm	Sec 3 µm

COOLING CIRCUIT

- Type	By water
- Fan	Puller
. Number of blades	10
. Diameter	508 mm
- Thermostat	
. Start opening	79 °C/84 °C
. Full opening	93 °C

TRANSMISSION

- Type	TURNER POWERTRAIN SYSTEMS
- Torque converter	SACHS
- Gear box	
. Number of forward gears	4
. Number of reverse gears	4
- Reversing gear	Electro-hydraulic

ANGLE GEAR-BOX

- Type	TURNER POWERTRAIN SYSTEMS
--------	------------------------------

FRONT AXLE

- Type	DANA
- Limited slip differential	45 %
- Hub reducers	Epicyclic

REAR AXLE

- Type	DANA
- Hub reducers	Epicyclic

BRAKE

MT 728 Série C-E2 MT 928 Série C-E2	
- Service brake	Foot pedal. Hydraulic brake, applied on the front wheels.
. Type	Multidisc brake immersed in oil.
- Parking brake	Mechanical hand lever applied on the output shaft of transmission.
. Type	Disc brake.
MT 732 Série C-E2 MT 732 Turbo Série C-E2 MT 932 Série C-E2 MT 932 Turbo Série C-E2 MT 1030 S Série 3-E2 MT 1030 S Turbo Série 3-E2	
- Service brake wheels.	Foot pedal. Hydraulic brake, applied on the front and rear
. Type	Multidisc brake immersed in oil.
- Parking brake	Mechanical hand lever applied on the output shaft of transmission.
. Type	Disc brake.

ELECTRIC CIRCUIT

- Earth	Negative
- Battery	12 V - 110 Ah - 750 A EN
- Alternator	12 V - 75 A
. Type	Denso A115i
. Tension regulator	Incorporated into the alternator
- Starter	12 V - 3,0 kW
. Type	Denso E95RL

FRONT AND REAR TYRES

DIMENSIONS	PRESSURE	TYRE LOAD	PRESSURE ON THE CONTACT SURFACE		AREA OF THE CONTACT SURFACE	
			HARD GROUND	LIGHT GROUND	HARD GROUND	LIGHT GROUND
18-19,5 16PR I224 TUBELESS ALLIANCE	73 PSI	FRONT UNLADEN 1550KG	3,24 KG/CM2	1,37 KG/CM2	479 CM2	1132 CM2
		FRONT LADEN 4400KG	5,87 KG/CM2	2,50 KG/CM2	750 CM2	1762 CM2
		REAR UNLADEN 2100KG	3,85 KG/CM2	1,63 KG/CM2	546 CM2	1288 CM2
400/80-24 156A8 PIA TUBELESS BF GOODRICH	40 PSI	REAR LADEN 850KG	2,29 KG/CM2	0,97 KG/CM2	371 CM2	877 CM2
		FRONT UNLADEN 1550KG	KG/CM2	KG/CM2	CM2	CM2
		FRONT LADEN 4400KG	KG/CM2	KG/CM2	CM2	CM2
14,9X24 T35 STABILARGE 18PR DUNLOP	50 PSI	REAR UNLADEN 2100KG	2,10 KG/CM2	0,87 KG/CM2	315 CM2	771 CM2
		REAR LADEN 850KG	1,42 KG/CM2	0,58 KG/CM2	180 CM2	444 CM2
		FRONT UNLADEN 1550KG	5,64 KG/CM2	1,94 KG/CM2	275 CM2	800 CM2
400/70-20 T37 150B 14PR TUBELESS DUNLOP	47 PSI	FRONT LADEN 4400KG	9,26 KG/CM2	3,08 KG/CM2	475 CM2	1430 CM2
		REAR UNLADEN 2100KG	6,27 KG/CM2	2,16 KG/CM2	335 CM2	970 CM2
		REAR LADEN 850KG	4,72 KG/CM2	1,63 KG/CM2	180 CM2	520 CM2
405/70-24 EM SPT9 158A2 TUBELESS DUNLOP	73 PSI	FRONT UNLADEN 1550KG	7,21 KG/CM2	2,35 KG/CM2	215 CM2	660 CM2
		FRONT LADEN 4400KG	10,48 KG/CM2	3,28 KG/CM2	420 CM2	1340 CM2
		REAR UNLADEN 2100KG	7,78 KG/CM2	2,50 KG/CM2	270 CM2	840 CM2
440/70-24 T37 147B TUBELESS DUNLOP	40 PSI	REAR LADEN 850KG	6,20 KG/CM2	2,00 KG/CM2	137 CM2	425 CM2
		FRONT UNLADEN 1550KG	7,21 KG/CM2	3,16 KG/CM2	215 CM2	490 CM2
		FRONT LADEN 4400KG	8,00 KG/CM2	3,52 KG/CM2	550 CM2	1250 CM2
400/80-24 T37 153B TUBELESS DUNLOP	46 PSI	REAR UNLADEN 2100KG	7,12 KG/CM2	3,13 KG/CM2	295 CM2	670 CM2
		REAR LADEN 850KG	7,73 KG/CM2	3,40 KG/CM2	110 CM2	250 CM2
		FRONT UNLADEN 1550KG	6,20 KG/CM2	1,78 KG/CM2	250 CM2	870 CM2
15,5/80-24 SGI 12PR TUBELESS GOODYEAR	58 PSI	FRONT LADEN 4400KG	9,36 KG/CM2	2,70 KG/CM2	470 CM2	1630 CM2
		REAR UNLADEN 2100KG	6,77 KG/CM2	1,94 KG/CM2	310 CM2	1080 CM2
		REAR LADEN 850KG	5,12 KG/CM2	1,47 KG/CM2	166 CM2	580 CM2
460/70R24 IT520 150A8 TUBELESS GOODYEAR	48 PSI	FRONT UNLADEN 1550KG	7,05 KG/CM2	1,96 KG/CM2	220 CM2	790 CM2
		FRONT LADEN 4400KG	10,11 KG/CM2	2,88 KG/CM2	435 CM2	1530 CM2
		REAR UNLADEN 2100KG	7,78 KG/CM2	2,12 KG/CM2	270 CM2	990 CM2
445/70R24 MPT IT510 151G TUBELESS GOODYEAR	60 PSI	REAR LADEN 850KG	5,90 KG/CM2	1,63 KG/CM2	144 CM2	520 CM2
		FRONT UNLADEN 1550KG	7,56 KG/CM2	2,04 KG/CM2	205 CM2	760 CM2
		FRONT LADEN 4400KG	11,73 KG/CM2	3,19 KG/CM2	375 CM2	1380 CM2
15,5-25 12PR SGL DL 2A GOODYEAR	44 PSI	REAR UNLADEN 2100KG	8,57 KG/CM2	2,31 KG/CM2	245 CM2	910 CM2
		REAR LADEN 850KG	7,08 KG/CM2	1,85 KG/CM2	120 CM2	460 CM2
		FRONT UNLADEN 1550KG	8,61 KG/CM2	2,25 KG/CM2	180 CM2	690 CM2
17,5LR24 XM27 145A8 TUBELESS MICHELIN	51 PSI	FRONT LADEN 4400KG	11,92 KG/CM2	3,10 KG/CM2	369 CM2	1420 CM2
		REAR UNLADEN 2100KG	9,25 KG/CM2	2,42 KG/CM2	227 CM2	866 CM2
		REAR LADEN 850KG	8,50 KG/CM2	2,24 KG/CM2	100 CM2	380 CM2
15,5R25 XHA TUBELESS MICHELIN	51 PSI	FRONT UNLADEN 1550KG	8,34 KG/CM2	2,78 KG/CM2	185 CM2	555 CM2
		FRONT LADEN 4400KG	9,84 KG/CM2	3,26 KG/CM2	443 CM2	1336 CM2
		REAR UNLADEN 2100KG	8,88 KG/CM2	2,92 KG/CM2	237 CM2	718 CM2
15,5R25 XHA TUBELESS MICHELIN	51 PSI	REAR LADEN 850KG	7,24 KG/CM2	2,38 KG/CM2	115 CM2	349 CM2
		FRONT UNLADEN 1550KG	8,47 KG/CM2	2,81 KG/CM2	183 CM2	551 CM2
		FRONT LADEN 4400KG	9,98 KG/CM2	3,32 KG/CM2	441 CM2	1327 CM2
15,5R25 XHA TUBELESS MICHELIN	51 PSI	REAR UNLADEN 2100KG	8,79 KG/CM2	2,92 KG/CM2	239 CM2	720 CM2
		REAR LADEN 850KG	7,39 KG/CM2	2,43 KG/CM2	115 CM2	350 CM2
		FRONT UNLADEN 1550KG	1,53 KG/CM2	1,44 KG/CM2	1010 CM2	1080 CM2
15,5R25 XHA TUBELESS MICHELIN	51 PSI	FRONT LADEN 4400KG	3,26 KG/CM2	2,15 KG/CM2	1350 CM2	2050 CM2
		REAR UNLADEN 2100KG	1,94 KG/CM2	1,56 KG/CM2	1080 CM2	1350 CM2
		REAR LADEN 850KG	0,91 KG/CM2	0,89 KG/CM2	930 CM2	955 CM2
15,5R25 XHA TUBELESS MICHELIN	51 PSI	FRONT UNLADEN 1550KG	KG/CM2	KG/CM2	CM2	CM2
		FRONT LADEN 4400KG	KG/CM2	KG/CM2	CM2	CM2
		REAR UNLADEN 2100KG	KG/CM2	KG/CM2	CM2	CM2
15,5R25 XHA TUBELESS MICHELIN	51 PSI	REAR LADEN 850KG	KG/CM2	KG/CM2	CM2	CM2

HYDRAULIC CIRCUIT

- Type of pump	Gear pump with flow divider	
. Capacity	43,8 cm ³	10
. Max. rating capacity unladen	5 L/mn	10
. Flow rate at 2300 rpm	1 L/mn	
. Flow rate at 1600 rpm	70 L/mn	
- Pressure	24	
. Lifting, tilting, telescoping, attachment circuit	0 Bar	14
. Steering circuit	0 Bar	
- Filtration		
. Return	15 μm	12
. Suction	5 μm	

SPECIFICATIONS

- Level of sound pressure in the driver's cab LpA (according to standard prEN 12053: 1995)	81 dB	
- Level of sound power in the LwA environment (according to directive 2000/14/EC modified by directive 2005/88/EC)	105 dB	
- Average weighted acceleration on driver's body (according to standard NF EN 13059)	m/s ²	
- The average weighted acceleration transmitted to the driver's hand/arm system (in accordance with ISO 5349-2) is less than 2.5 m/s ²		
- Speed of movement of lift truck in standard configuration on horizontal ground (except particular conditions)		
. Forward unladen	27,3 km/h	
. Reverse unladen	27,3 km/h	
- Standard lift height	6900 mm	
- Rated capacity with standard attachment	3200 kg	
- Load center	24 in.	
- Weight of forks (each)	68 kg	
- Lifting motions (jib retracted)		
. Unladen lifting	6,7 s	40,4 m/mn
. Laden lifting	7,3 s	37,0 m/mn
. Unladen lowering	5,0 s	54,1 m/mn
. Laden lowering	4,7 s	57,5 m/mn
- Telescoping motions (lifting jib)		
. Unladen extending	6,3 s	25,7 m/mn
. Laden extending	6,8 s	23,8 m/mn
. Unladen retracting	3,3 s	49,1 m/mn
. Laden retracting	3,0 s	54,0 m/mn
- Reverse tilt time unladen	2,8 s	44,9 °/s
- Forward tilt time unladen	2,3 s	54,6 °/s
- Lift truck weight with standard attachment		
. Unladen	7250 kg	
. Rated load	10450 kg	
- Axle weight with attached equipment (transport position)		
. Front unladen	3060 kg	

	rated load	8785 kg
. Rear	unladen	4190 kg
	rated load	1665 kg
- Tensile strain at coupling hook		
	. Unladen	5700 daN
	. Rated load	8400 daN
- Break out force with bucket		
	(according to standard ISO 8313)	7400 daN

DIMENSIONS AND LOAD CHART
E2

MT 732 Série C-

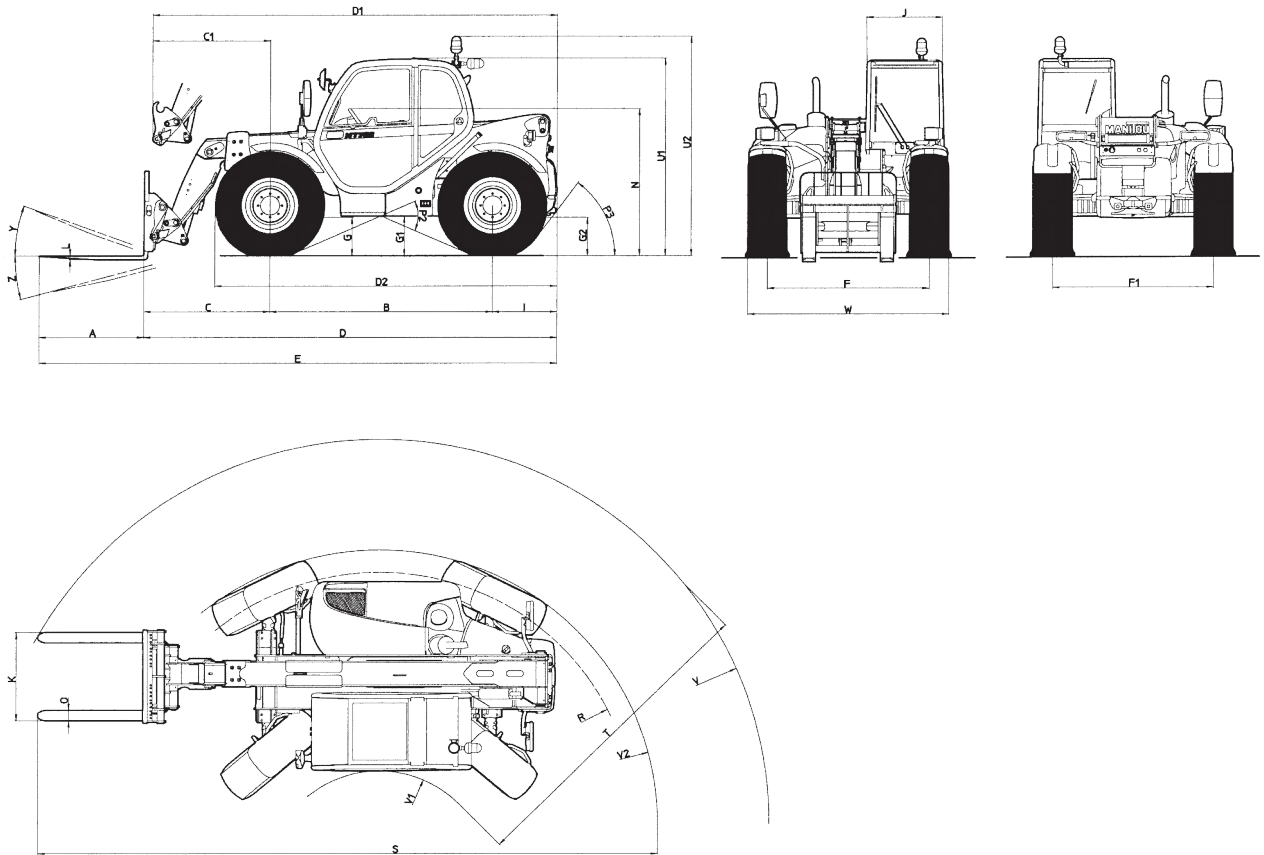

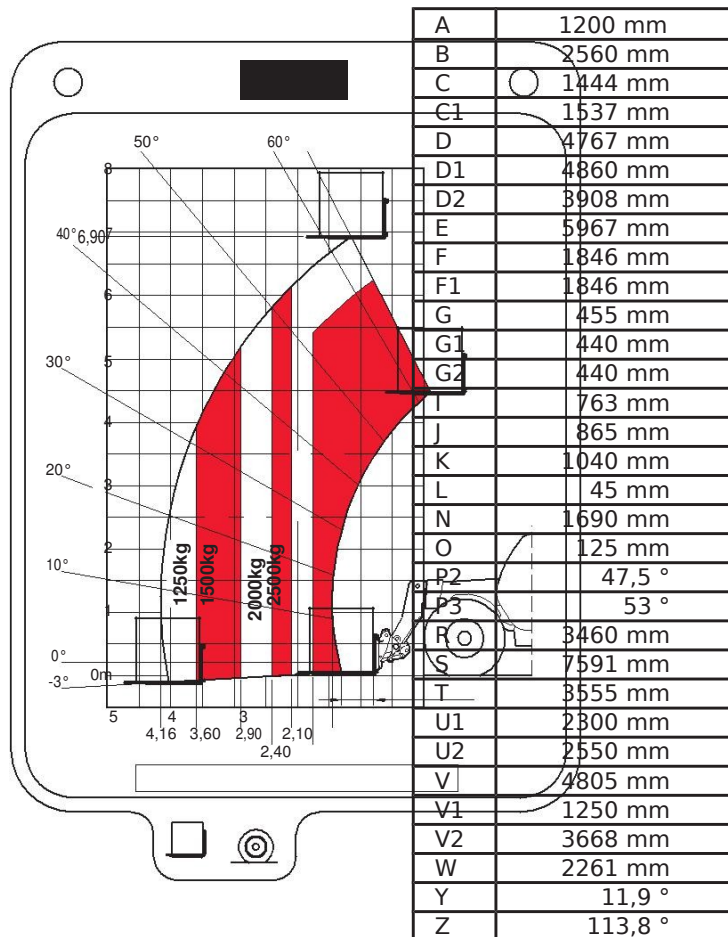

INSTRUMENTS AND CONTROLS

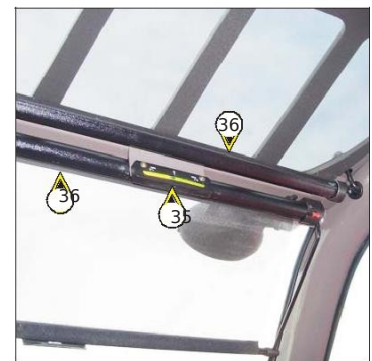
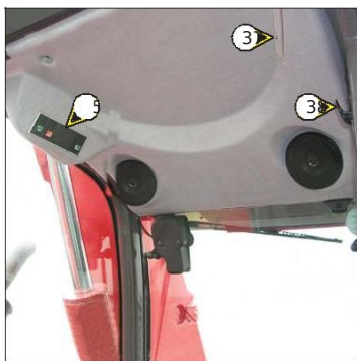
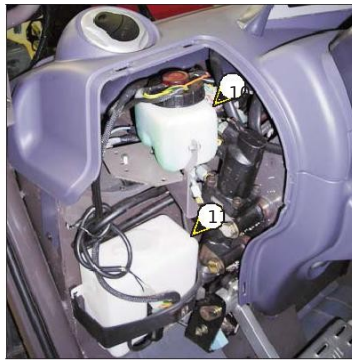
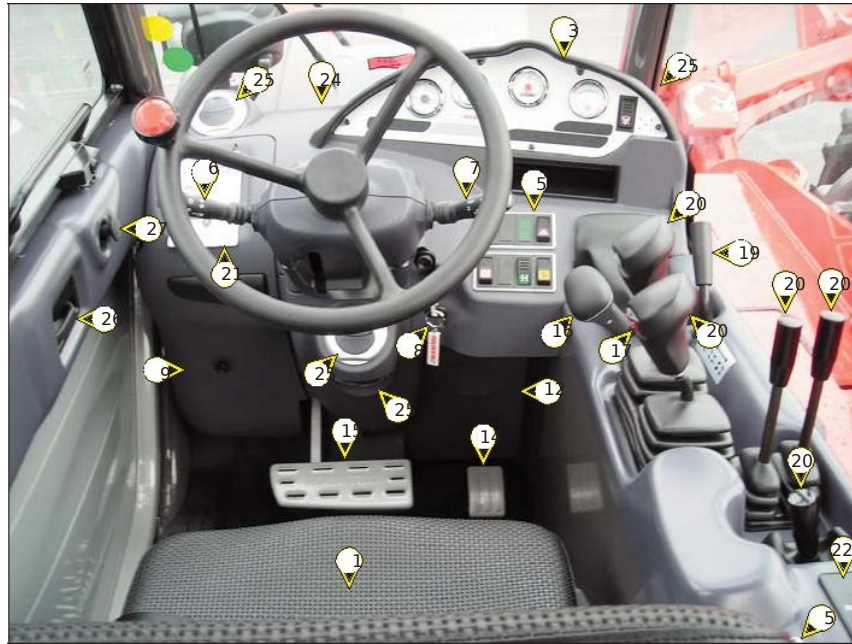

DESCRIPTION

- 1 - DRIVER'S SEAT
- 2 - SAFETY BELT
- 3 - CONTROL AND SIGNAL LIGHTS PANEL
- 4 - N/A
- 5 - SWITCH PANELS
- 6 - LIGHT SWITCH, HORN AND INDICATOR SWITCH
- 7 - FRONT AND REAR WINDSCREEN WIPER SWITCH
- 8 - IGNITION SWITCH
- 9 - BRAKING OIL TANK AND WINDSCREEN WASHER ACCESS PANEL
- 10 - BRAKING OIL TANK
- 11 - WINDSCREEN WASHER TANK
- 12 - FUSE AND RELAY ACCESS PANEL
- 13 - FUSE AND RELAY
- 14 - ACCELERATOR PEDAL
- 15 - SERVICE BRAKE AND TRANSMISSION CUT-OFF PEDAL
- 16 - GEAR LEVER AND TRANSMISSION CUT-OFF
- 17 - REVERSING GEAR
- 18 - PARKING BRAKE LEVER
- 19 - STEERING SELECTION
- 20 - HYDRAULIC CONTROLS AND TRANSMISSION CUT-OFF
- 21 - LOAD CHARTS FILE
- 22 - HEATER CONTROL
- 22 - AIR CONDITIONING CONTROLS (OPTION AIR CONDITIONING)
- 23 - CAB FILTER VENTILATORS
- 24 - WINDSCREEN DEMIST VENTS
- 25 - HEATING VENTS
- 26 - DOOR LOCK
- 27 - LOCKING HANDLE FOR UPPER HALF DOOR
- 28 - RELEASING BUTTON FOR UPPER HALF DOOR
- 29 - HANDLE FOR REAR WINDOW OPENING
- 30 - TOOL BOX AND DOCUMENT HOLDER
- 31 - FRONT LIGHTS (NOT ILLUSTRATED)
- 32 - REAR LIGHTS (NOT ILLUSTRATED)
- 33 - FLASHING LIGHT (NOT ILLUSTRATED)
- 34 - DOCUMENT HOLDER NET
- 35 - SPIRIT LEVEL
- 36 - SUN VISOR
- 37 - ROOF LIGHT
- 38 - HOOK

NOTE: All the terms such as: RIGHT, LEFT, FRONT, REAR are meant for an observer seated on driver's seat and looking in front of him.

1 - DRIVER'S SEAT

DESIGNED FOR MAXIMUM COMFORT, THIS SEAT CAN BE ADJUSTED AS FOLLOWS.

LONGITUDINAL ADJUSTMENT

- Pull locking lever 1 towards the right.
- Slide the seat to the required position.
- Release the lever and be sure it returns to the lock position.

SEAT SUSPENSION ADJUSTMENT

- Refer to the seat's graduation.
- Turn handle 2 depending on the driver's weight.

ADJUSTMENT OF THE ANGLE OF THE BACK-REST

- Pull locking lever 3 upwards.
- Slide the back-rest to the required position.
- Release the lever and be sure it returns to the lock position.

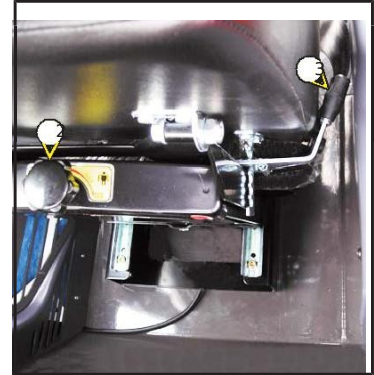

1 - DRIVER'S SEAT (OPTION)

DESIGNED FOR MAXIMUM COMFORT, THIS SEAT CAN BE ADJUSTED AS FOLLOWS.

WEIGHT ADJUSTMENT (FIG. A)

It is advised that the weight be adjusted when the driver is not sitting in the cab. - Refer to graduation 1 of the seat.

- Turn handle 2 according to the driver's weight. ² ₁ NOTE: To avoid any health problems, it is recommended that the weight should be checked and adjusted before starting up the lift truck.

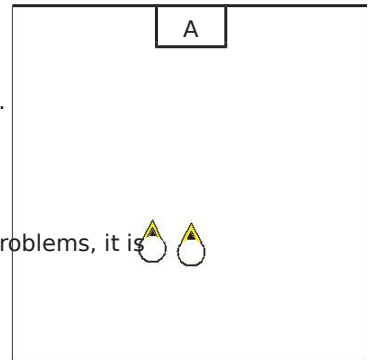

SEAT HEIGHT ADJUSTMENT (FIG. B)

Raise the seat to the desired position, until you hear the ratchet click. If you raise the seat above the last notch (stop), the seat drops down to the lowest position.

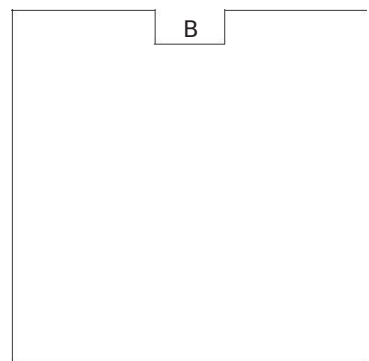

SEAT BACK-REST ANGLE ADJUSTMENT (FIG. C)

The back-rest angle of the seat may be adjusted to suit the individual.

- Press the left-hand button while pushing on the seat or relaxing pressure on the seat to find a comfortable position.

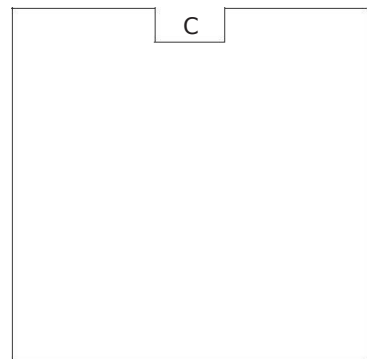

SEAT DEPTH ADJUSTMENT (FIG. D)

The depth of the seat may be adjusted to suit the individual.

- Press the right-hand button while raising or lowering the seat to find the desired position.

EXTENDING THE HEAD-REST (FIG. E)

- The height of the back-rest can be adjusted by pulling it upwards (the notches will click) up to the stop.
- The head-rest can be removed by applying sufficient pressure to pull it off the stop.

LUMBAR ADJUSTMENT (FIG. F)

This increases the comfort of the seat and the driver's freedom of movement.

- Turn the handle either left or right to adjust the height or depth of the lumbar support.

ADJUSTMENT OF THE ANGLE OF THE BACK-REST (FIG. G)

- Support the back-rest, pull the lever and position the back-rest to find the desired position.



If you do not support the back-rest when making adjustments, it swings completely forwards.

LONGITUDINAL ADJUSTMENT (FIG. H)

- Adjust the locking lever until you reach the position required. This then locks and the seat will not shift into another position.

MAINTENANCE (FIG. I)

Dirt may adversely affect the correct functioning of the seat. For this reason, make sure your seat is always clean.

- To clean or change the cushions, simply remove them from the seat frame.



A rocking head-rest increases the risk of an accident!

Avoid wetting the cushion fabric when cleaning. Check the resistance of the fabric on a small hidden area before using any fabric or plastic cleaner.

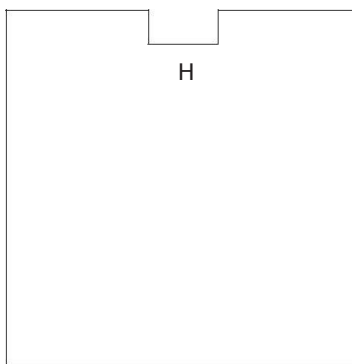

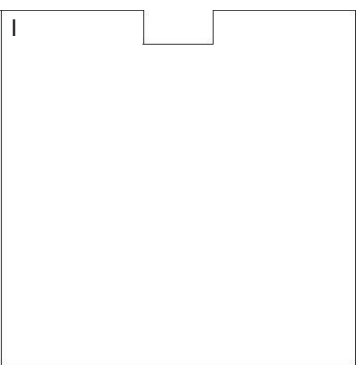
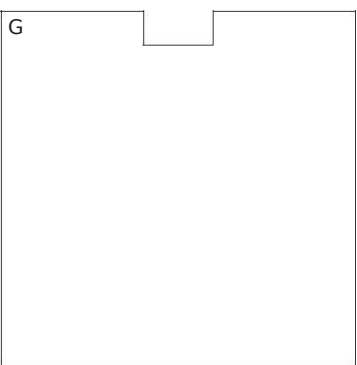
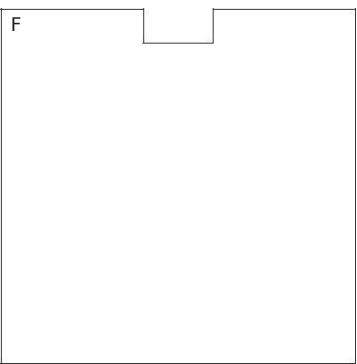
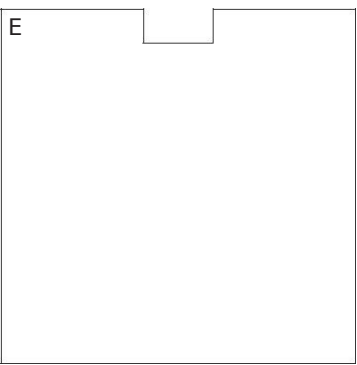
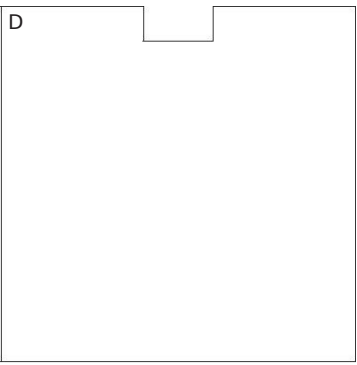

1 - PNEUMATIC DRIVER'S SEAT (OPTION)

DESIGNED FOR MAXIMUM COMFORT, THIS SEAT CAN BE ADJUSTED AS FOLLOWS.

2 - 16

WEIGHT ADJUSTMENT (FIG. A)

It is advised that you adjust the seat according to your weight when sitting.

- Switch on lift truck ignition.
- Push or pull lever 1 until green appears in display 2 indicating correct adjustment according to your weight.

NOTE: To avoid any health problems, it is recommended that the weight should be checked and adjusted before starting up the lift truck.

SEAT HEIGHT ADJUSTMENT (FIG. B)

When weight adjustment has been carried out, you can then modify seat height.

- Keep the ignition switched on.
- Push or pull lever 1 until green appears and adjust the height of the seat while checking that the green in display 2 remains visible.

 *To avoid causing any damage, do not activate the compressor for over 1 minute.*

SEAT BACK-REST ANGLE ADJUSTMENT (FIG. C)

The back-rest angle of the seat may be adjusted to suit the individual.

- Press the left-hand button while pushing on the seat or relaxing pressure on the seat to find a comfortable position.

SEAT DEPTH ADJUSTMENT (FIG. D)

The depth of the seat may be adjusted to suit the individual.

- Press the right-hand button while raising or lowering the seat to find the desired position.

EXTENDING THE HEAD-REST (FIG. E)

- The height of the back-rest can be adjusted by pulling it upwards (the notches will click) up to the stop.
- The head-rest can be removed by applying sufficient pressure to pull it off the stop.

LUMBAR ADJUSTMENT (FIG. F)

This increases the comfort of the seat and the driver's freedom of movement.

- Turn the handle either left or right to adjust the height or depth of the lumbar support.

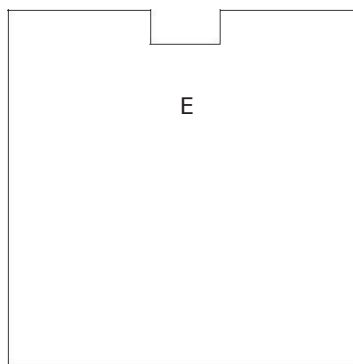

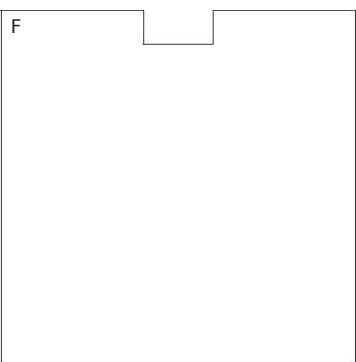
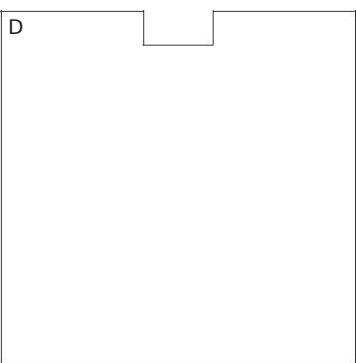
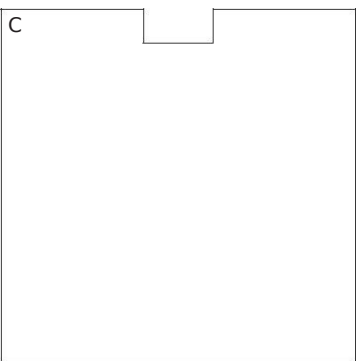
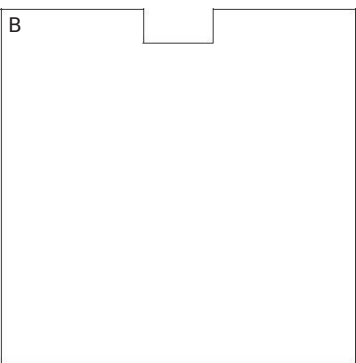
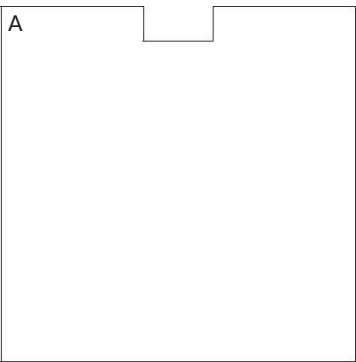

ADJUSTMENT OF THE ANGLE OF THE BACK-REST (FIG. G)

- Support the back-rest, pull the lever and position the back-rest to find the desired position.

2 - 17



If you do not support the back-rest when making adjustments, it swings completely forwards.

HORIZONTAL SHOCK ABSORBER (FIG. H)

In certain conditions (e.g. driving with a trailer) it is advised that a horizontal shock absorber be used. The driver's seat is thus better able to absorb jerks in the direction of travel.

- Position 1: Horizontal shock absorber fitted.
- Position 2: Horizontal shock absorber removed.

LONGITUDINAL ADJUSTMENT (FIG. I)

- Adjust the locking lever until you reach the position required. This then locks and the seat will not shift into another position.

MAINTENANCE (FIG. J)

Dirt may adversely affect the correct functioning of the seat. For this reason, make sure your seat is always clean.

- To clean or change the cushions, simply remove them from the seat frame.



A rocking head-rest increases the risk of an accident!

Avoid wetting the cushion fabric when cleaning. Check the resistance of the fabric on a small hidden area before using any fabric or plastic cleaner.

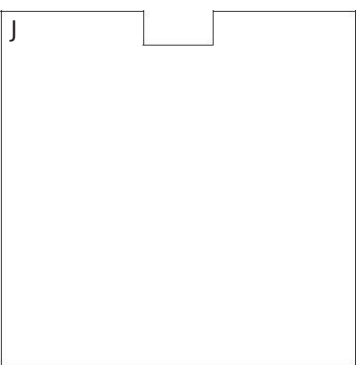
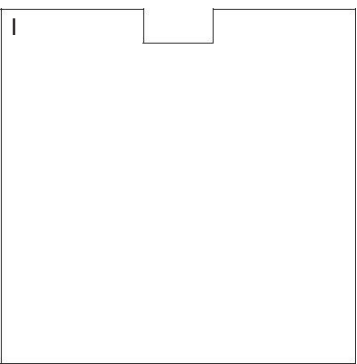
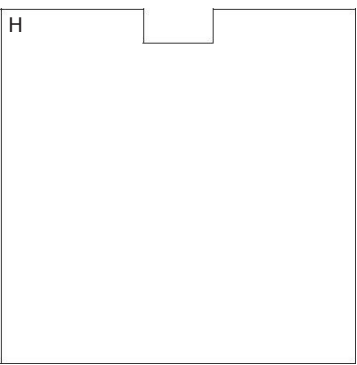
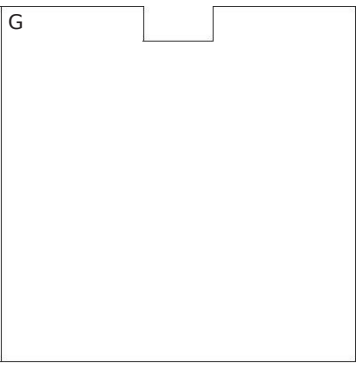

1 - PNEUMATIC DRIVER'S SEAT (OPTION)

2 - 18

FOR MAXIMUM COMFORT, THIS SEAT CAN BE ADJUSTED AS FOLLOWS.

WEIGHT ADJUSTMENT (FIG. A)

It is advisable to adjust the seat according to your weight while sitting.

- Switch on the lift truck ignition.
- Pull or push lever 1 briefly. Adjustment is automatic.

NOTE: To avoid any health problems, it is recommended that the weight should be checked and adjusted before starting the lift truck.

SEAT HEIGHT ADJUSTMENT (FIG. B)

When weight adjustment has been carried out, you can then alter the seat height.

- Keep the ignition switched on.
- Push or pull lever 1 to adjust the height of the seat.

 *To avoid causing any damage, do not operate the compressor for over 1 minute.*

SEAT BACK-REST ANGLE ADJUSTMENT (FIG. C)

The back-rest angle of the seat may be adjusted to suit the individual.

- Press the left-hand button while pushing on the seat or relaxing pressure on the seat to find a comfortable position.

SEAT DEPTH ADJUSTMENT (FIG. D)

The depth of the seat may be adjusted to suit the individual.

- Press the right-hand button while raising or lowering the seat to find the desired position.

EXTENDING THE HEAD-REST (FIG. E)

- The height of the back-rest can be adjusted by pulling it upwards (the notches will be heard clicking) up to the stop.
- The head-rest can be removed by applying sufficient pressure to pull it off the stop.

LUMBAR ADJUSTMENT (FIG. F)

This increases the comfort of the seat and the driver's freedom of movement.

- Press the raise and lower switches to adjust the curvature of the seat back to your requirements.

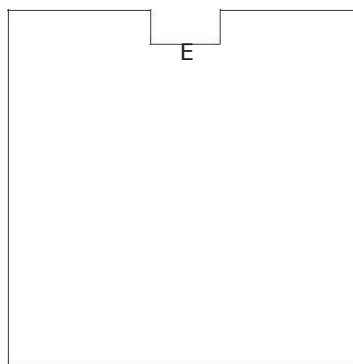

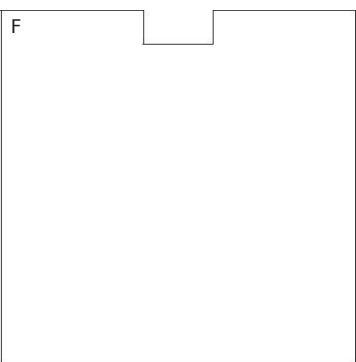
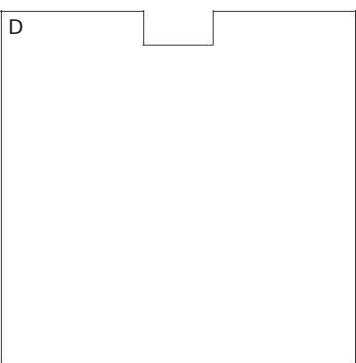
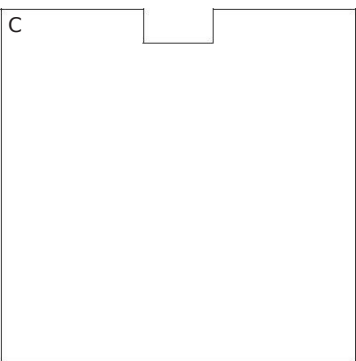
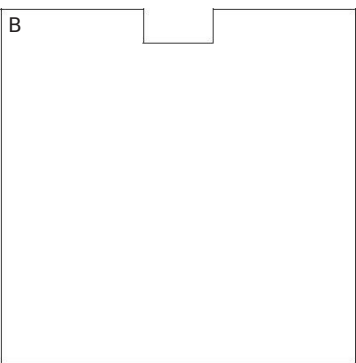
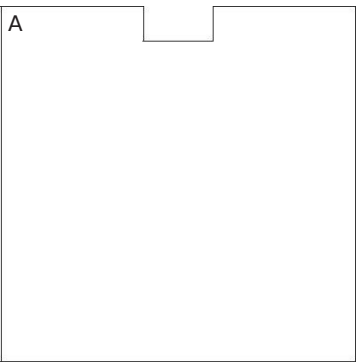

ADJUSTMENT OF THE ANGLE OF THE BACK-REST (FIG. G)

- Support the back-rest, pull the lever and tilt the back-rest to the desired position.

2 - 19

 *If you do not support the back-rest when making adjustments, it will swing fully forward.*

HORIZONTAL SHOCK ABSORBER (FIG. H)

In certain conditions (e.g. Driving with a trailer) it is advisable to use a horizontal shock absorber. The driver's seat is thus better able to absorb shocks in the direction of travel.

- Position 1: Horizontal shock absorber fitted.
- Position 2: Horizontal shock absorber removed.

DAMPING (FIG. I)

The damping of the seat can be adjusted to suit the nature of the terrain. The comfort of the seat is thus adjustable to suit your requirements.

- Position 1: Soft damping.
- Position 2: Hard damping.

LONGITUDINAL ADJUSTMENT (FIG. J)

- Engage the locking lever in the position shift into another position required. This then locks and the seat can not be moved to another position.

MAINTENANCE (FIG. K)

Dirt may adversely affect the correct functioning of the seat. For this reason, make sure your seat is always clean.

- To clean or replace the cushions, simply remove them from the seat frame.

 *A rocking back-rest increases the risk of an accident!*

Avoid wetting the cushion fabric when cleaning. Check the resistance of the fabric on a small hidden area before using any fabric or plastic cleaner.

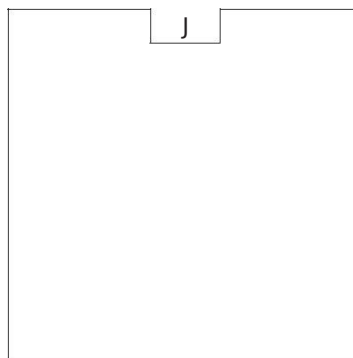

2 - SAFETY BELT

- Sit correctly on the seat.
- Check that seat belt is not twisted.
- Place the seat belt at hip level.
- Attach the seat belt and check that it locks.
- Adjust the seat belt to your body shape without squeezing your hip and without excessive play.

 *Under no circumstances should the lift truck be used if the seat belt is defective (fixing, locking, cuts, tears, etc.). Repair or replace the seat belt immediately.*

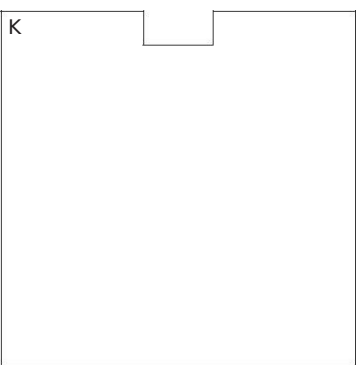
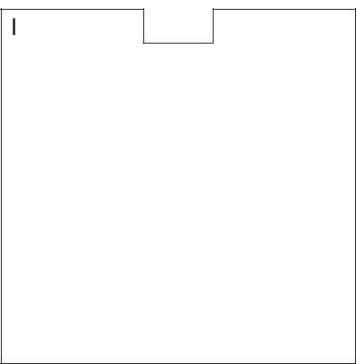
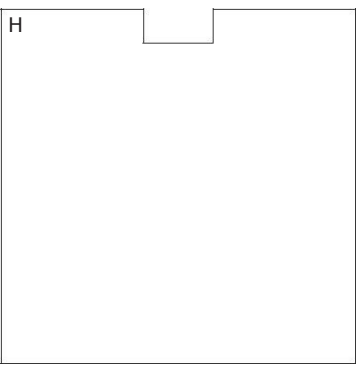
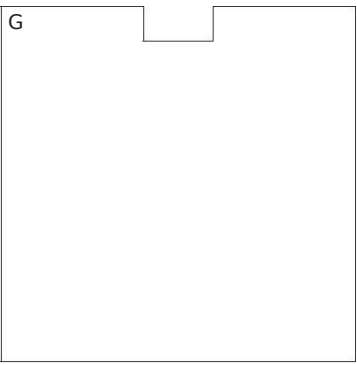

3 - CONTROL AND SIGNAL LIGHTS PANEL



A - HOURMETER

B - I.C. ENGINE WATER TEMPERATURE

Temperature zone B1 - Blue zone (0° - 50°)

B2 - Green zone (50° - 100°)

B3 - Black/red zone (100° - 105°)

B4 - Red zone (105° - 120°)

NOTE: Red indicator light "J" comes on between zone B3 and B4.

C - FUEL LEVEL

Red zone C1 indicates that you are using the reserve supply and that time of use is limited.

D - TIME DIAL

SIGNAL LIGHTS

When activating the electrical system of the lift truck, all the red lamps and the panel's buzzer must light to indicate their good working order. If one of the red lamps or the buzzer does not function, carry out the necessary repairs.



RED TRANSMISSION OIL PRESSURE LAMP

The lamp and the buzzer come on when the pressure in the transmission, when driving forward, is abnormally low. Stop the lift truck and look for the cause (insufficient transmission oil level, internal leak in the transmission, etc.).

NOTE: The signal light operates in forward travel conditions only, the signal should be ignored when the lift truck has stopped or is idling.



RED TRANSMISSION OIL TEMPERATURE LAMP

The lamp and the buzzer come on when the converter oil temperature is abnormally high. Stop the lift truck and look for the cause of this overheating.



RED BRAKING OIL LEVEL LAMP

If the lamp and the buzzer come on, when the lift truck is running, stop the I.C. engine immediately and check the braking oil level. In the event of an abnormal dropping of the level, consult your dealer.



RED PARKING BRAKE LAMP

This lamp comes on when the parking brake is applied.



RED ALTERNATOR CHARGE LAMP

If the lamps E - F - H - I - J - K and the buzzer come on, when the lift truck is running, stop the I.C. engine immediately and check the electrical circuit as well as the alternator belt.



RED I.C. ENGINE OIL PRESSURE LAMP

If the lamp and the buzzer come on when the lift truck is running, stop the I.C. engine immediately and look for the cause (see oil level in I.C. engine crankcase).



RED I.C. ENGINE WATER TEMPERATURE LAMP

If the lamp and the buzzer come on when the lift truck is running, stop the I.C. engine immediately and investigate the cooling circuit for the cause of the malfunction.



RED LAMP - AIR FILTER OR HYDRAULIC RETURN FILTER CLOGGED

The lamp and buzzer come on when the air filter cartridge or the hydraulic return oil filter cartridge is clogged up. Stop the lift truck and carry out the necessary repairs (see cleaning and replacement requirements in chapter: 3 - MAINTENANCE: FILTERS CARTRIDGES AND BELTS).



GREEN DIRECTION INDICATOR LAMP



GREEN SIDELIGHTS LAMP



GREEN LOW BEAM LAMP



BLUE MAIN BEAM LAMP



OPTION



OPTION



OPTION



OPTION

This device warns the operator that the lift truck is approaching the limit of longitudinal stability. However, lateral stability can reduce the load chart in the upper part, and this reduction is not detected by the longitudinal stability alarm.



The operator must always respect the lift truck load chart.

OPERATION

When the lift truck is switched on a control test is automatically carried out.

- Correct operation: All leds and the sound alarm function continuously for 2 seconds.
- Faulty operation: All leds and sound alarm function intermittently (stop the lift truck and consult your dealer, never attempt a repair yourself).

A - LEDS (VISUAL ALARM) (FIG. A)

- A1 - 4 green leds: There is a large reserve of longitudinal stability.
- A2 - 2 yellow leds: The lift truck is approaching the limit of longitudinal stability, move carefully.
- A3 - 1 red led: The lift truck is very near at the limit of longitudinal stability. The alarm sounds simultaneously with a slow intermittent sound. Move very carefully.
- A4 - 1 red led: The lift truck is at the authorized limit of longitudinal stability. The alarm sounds simultaneously with a speed intermittent sound. Only make de-aggravating hydraulic movements in the following order ; retract and raise the jib.

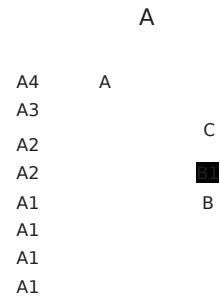

B - SOUND ALARM SWITCH (FIG. A)

Used to switch off the sound alarm when using the lift truck with loading and earth moving buckets. When it is switched off, the red led B1 indicates that the sound alarm has been cut off and only the visual alarm is working. Under other operating conditions, the sound alarm must be switched on.

B

C - TEST SWITCH (FIG. A)

Press the switch to verify at any time that the longitudinal stability alarm is working. NOTE: This test does not verify that the alarm is correctly set ; this must be checked at every periodic service.

- Correct operation: All leds and the sound alarm function continuously.
- Faulty operation: All leds and the sound alarm function intermittently (stop the lift truck

and consult your dealer, never attempt a repair yourself).

D

D - STRAIN GAUGE (FIG. B)

Disassembly or adjustment of the strain gauge is prohibited, this must only be done by specially trained personnel, consult your dealer.

MT 728 Série C-E2

MT 928 Série C-E2

NOTE: The cutting-off of "SIMPLE" hydraulic movements is installed in series (See: 2 - DESCRIPTION: DESCRIPTION AND USE OPTIONS).

5 - SWITCH PANEL

NOTE: The location of the switches may vary depending on the options.

A - OPTION

MT 732 Série C-E2

MT 732 Turbo Série

C-E2 MT 932 Série

C-E2

MT 932 Turbo Série C-E2

MT 1030 S Série 3-E2

MT 1030 S Turbo Série 3-E2

- OPTION Electrical jib provision (See: 2 - DESCRIPTION: DESCRIPTION AND USE OPTIONS).

B - OPTION



C - WHEEL ALIGNMENT LAMPS

D - WARNING LIGHTS

E - REAR FOG LIGHT

F - OPTION

MT 732 Série C-E2

MT 732 Turbo Série

C-E2 MT 932 Série

C-E2

MT 932 Turbo Série C-E2

MT 1030 S Série 3-E2

MT 1030 S Turbo Série 3-E2

- OPTION Self-cleaning fan (See: 2 - DESCRIPTION: DESCRIPTION AND USE OPTIONS).

G - STEERING SELECTION

H - TRANSMISSION CUT-OFF

The switch selects transmission cut-off to the service brake pedal or the hydraulic controls lever.

Position 1: Indicator light on, transmission cut-off to service brake pedal effected.

Position 2: Indicator light off, transmission cut-off to hydraulic control lever effected.

NOTE: In all cases transmission cut-off can be effected using the gear lever.

USE OF TRANSMISSION CUT-OFF

Transmission cut-off to brake pedal (position 1).

- When loading.

Transmission cut-off to hydraulic controls lever (position 2).

- When driving.
- For inching and continuous stopping and starting (delicate handling). In order to optimise hydraulic movements, cut off transmission to the hydraulic controls lever.
- Starting up on a slope.

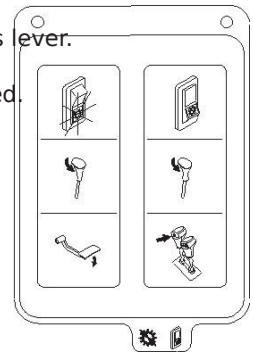

I - REVOLVING LIGHT

J - OPTION FRONT AND REAR WORKING LIGHTS

K - OPTION

MT 732 Série C-E2

MT 732 Turbo Série

C-E2 MT 932 Série

C-E2

MT 932 Turbo Série C-E2

MT 1030 S Série 3-E2

MT 1030 S Turbo Série 3-E2

- OPTION Jib head light

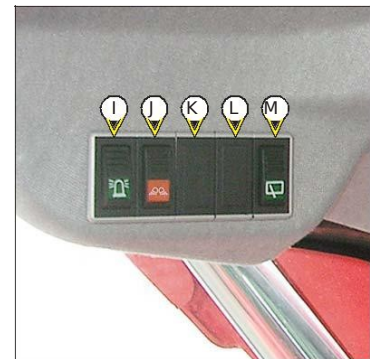

L - REAR WINDOW DEFROSTING OPTION

M - SIDE WINDSCREEN WIPER + ROOF WINDSCREEN WIPER OPTION

N - OPTION

O - OPTION

P - OPTION

MT 732 Série C-E2 N O P Q MT 732 Turbo Série C-E2

MT 932 Série C-E2

MT 932 Turbo Série C-E2

MT 1030 S Série 3-E2

MT 1030 S Turbo Série 3-E2

- OPTION Attachment hydraulic locking device (See: 2 - DESCRIPTION:

DESCRIPTION AND USE OPTIONS).

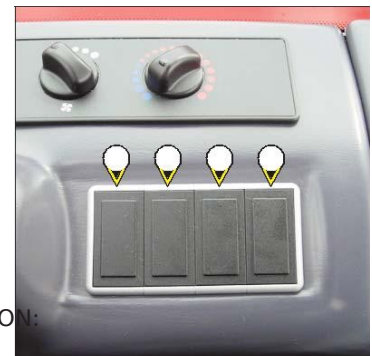

Q - OPTION

g
h
t
h
a
n
d
d
i
r
e
c
t
i
o
n
i
n
d
i
c
a
t
o
r
s
f
l
a
s
h
.
C
-
T
h
e
l
e
f
t
h
a
n
d
d
i
r
e
c
t
i
o
n
i
n
d
i
c
a

2021/12

tors flash. D - The sidelights and the rear lights are on.
 E - The dipped headlights and the rear lights are on.
 F - The main beam headlights and the rear lights are on. G - Headlight signal.

Pressing the switch sounds the horn.

NOTE: The positions D - E - F - G can be carried out without the ignition being on.

7 - FRONT AND REAR WINDSCREEN WIPER SWITCH

This switch controls the operation of the front and rear windscreen wipers.

- A - Front windscreen wiper off.
- B - Front windscreen wiper low speed setting. C - Front windscreen wiper high speed setting. D - Front windscreen wiper intermittent setting. E - Rear windscreen wiper off.
- F - Rear windscreen wiper on.

NOTE: These functions will only work when the ignition is switched on.

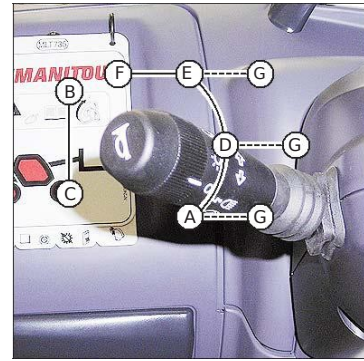

8 - IGNITION SWITCH

The key switch has five positions:

P - Ignition off, parking position.

O - Ignition switched off and I.C. engine stopped.

I - Ignition on.

II - Heating.

III - The I.C. engine starts, return to position i as soon as the key is released.

9 - BRAKING OIL TANK AND WINDSCREEN WASHER ACCESS PANEL

- Loosen screw 1 and lift up the brake fluid and windscreen washer access panel.



10 - BRAKING OIL TANK

See: 3 - MAINTENANCE: B - EVERY 50 HOURS SERVICE.

11 - WINDSCREEN WASHER TANK

See: 3 - MAINTENANCE: B - EVERY 50 HOURS SERVICE.



12 - FUSE AND RELAY ACCESS PANEL

- Lift up the fuse and relay access panel 12.



13 - FUSE AND RELAY

A sticker on the inside of the access panel gives a clear display of the use of

the components described below.

K0 - OPTION Air conditioning.

K1 - OPTION.

~~K2 - Transmission cut-off relay.~~

K3 - Reverse gear relay.

K4 - Forward gear relay..

K5 - Buzzer.

K6 - OPTION Electrovalve on jib head. (B C E F G H)

- OPTION Electrical jib provision. (B C E F G H)

- OPTION Electrovalve on jib head + Attachment hydraulic locking device. (B C E F G H)

- OPTION. (A

D)

K7 - Cutting off "simple" hydraulic movements. (A D)

- OPTION Cutting off "simple" hydraulic movements. (B C E F G H)

- OPTION Cutting off "aggravating" hydraulic movements.

K8 - Safety system starting switch relay

K9 - Flashing unit.

K14 - OPTION Diesel decongealant. (B C E F G H)

K16 - Preheating I.C. engine relay.

NOTE: Replace a used fuse with a new fuse of the same quality and capacity.

Never reuse a repaired fuse.

- (10A
F1 MAXI)

- Safety stabilisers (7,5A). (G H)

- OPTION. (A B C D E F)

- (15A
F2 MAXI)

- OPTION Working tail light (10A).

- (10A
F3 MAXI)

- Rear windscreen wiper (7,5A).
- OPTION Roof windscreen wiper (7,5A).
- OPTION Side windshield wiper (7,5A).

- (10A
F4 MAXI)

- Stop I.C. engine electrovalve (7,5A).
- OPTION.

- (10A
F5 MAXI)
- (7,5A
F6 MAXI)

- Flashing light (7,5A).

- (15A
F7 MAXI)

- Alignment of the wheels (5A).

- OPTION (10A).
- Cutting off "simple" hydraulic movements (10A). (A D)
- OPTION Cutting off "simple" hydraulic movements (10A). (B C E F G H)
- OPTION Cutting off "aggravating" hydraulic movements (10A).

A: MT 728 Série C-
E2
B: MT 732 Série C-
E2
C: MT 732 Turbo Série
C-E2
D: MT 928 Série C-
E2
E: MT 932 Série C-
E2
F: MT 932 Turbo Série C-
E2
G: MT 1030 S Série
3-E2
H: MT 1030 S Turbo Série
3-E2

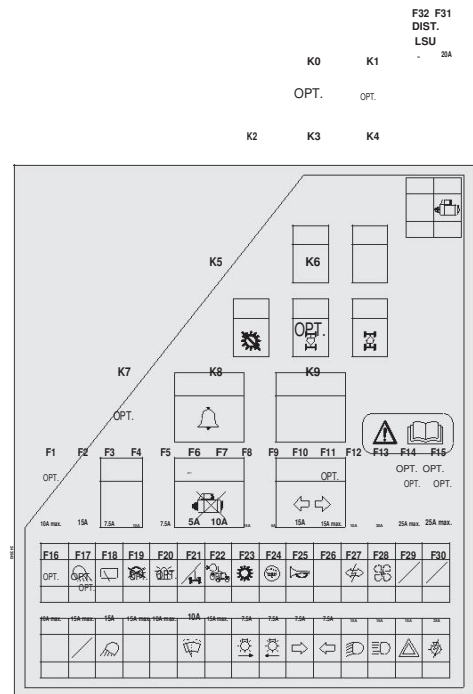

- (15A F8 MAXI)
 - Reversing gear (15A).
 - Transmission cut-off (15A).
 - Reverse buzzer alarm (15A).
 - Reverse lights (15A).
- (10A F9 MAXI)
 - Control instruments panel (5A).
- (15A F10 MAXI)
 - Sound alarm (15A).
 - Stop switch (15A).
- (15A F11 MAXI)
 - OPTION Jib head light (10A). (B C E F G H)
 - OPTION Blue front and rear working lights (10A). (B C E F)
 - OPTION. (A D)
- (10A F12 MAXI)
 - Indicator power supply (10A).
- (35A F13 MAXI)
 - Heating (30A).
- (25A F14 MAXI)
 - OPTION.
- (25A F15 MAXI)
 - OPTION.
- (10A F16 MAXI)
 - OPTION Air conditioning (7,5A).

- F17 - (15A MAXI) - OPTION Electrovalve on jib head (10A). (B C E F G H)
- OPTION Electrovalve on jib head + attachment hydraulic locking device (10A). (B C E F G H)
- OPTION Electrical jib provision (10A). (B C E F G H)
- OPTION Anti-theft device provision (10A).
- OPTION Anti-theft system (10A).
- OPTION Starter fuse (10A).
- OPTION Anti-start system (10A). (B C E F G H)
- OPTION Self-cleaning fan (10A). (B C E F G H)
- OPTION Electrovalve on jib head + self-cleaning fan(15A). (B C E F G H)
- F18 - (15A MAXI) - OPTION Front working head light (15A).
- F19 - (15A MAXI) - OPTION Rear window defrosting (15A).
- F20 - (10A MAXI) - OPTION Pneumatic seat (10A).
- F21 - (10A MAXI) - Windshield wiper (10A).
- F22 - (15A MAXI) - OPTION.
- F23 - (10A MAXI) - Right sidelight (7,5A).



- Sidelight indicator light (7,5A).
- Control panel lighting (7,5A).
- OPTION Number plate lighting (7,5A). (B C E F G H)

K14
F44

K
1
6

F24 - MAXI - Left sidelights
(10A) (7,5A).
F25 - MAXI - Right indicators
(10A) (7,5A).
F26 MAXI - Left indicators
- (10A) (7,5A).
F27 - (15A MAXI) - Low beam (15A).



- Low beam indicator light (15A).
- Rear fog light (15A).
- F28 - (15A MAXI) - Main beam (15A).
- Main beam lamp (15A).
- F29 - (25A MAXI) - Hazard warning lights power supply (15A).
- Roof light (15A).
- OPTION (+)permanent (15A).
- F30 - (25A MAXI) - Light switch power supply, horn and indicators (25A).
- F31 - (20A MAXI) - Starter (20A).

Remove casing 1 and cover 2 for access to fuses F40 to F44 and to relay K16.

- F40 - (40A
MAXI) - Lift truck electrical equipment (40A).
- F41 -
(40AMAXI) - Lift truck electrical equipment (40A).
- F42 -
(80AMAXI) - Preheating I.C. engine (80A).
- F43
- (80AMAXI) - Alternator (80A).
- F44 - OPTION Diesel decongealant (15A). (B C
- (15AMAXI) E F G H)

14 - ACCELERATOR PEDAL

MT 732 Série C-E2
MT 732 Turbo Série C-E2
MT 932 Série C-E2
MT 932 Turbo Série C-E2
MT 1030 S Série 3-E2
MT 1030 S Turbo Série 3-E2

NOTE: There is an OPTIONAL hand-operated accelerator in the cabin.

15 - SERVICE BRAKE PEDAL AND TRANSMISSION CUT-OFF

MT 728 Série C-E2
MT 928 Série C-E2

The pedal applies on the front wheels by an hydraulic brake system, and allows the lift truck to be slowed down and stopped. Depending on the position of the transmission cut-off switch, it enables the free travel to cut off transmission (see: 2 - DESCRIPTION: 5 - SWITCHES PANEL).

MT 732 Série C-E2
MT 732 Turbo Série
C-E2 MT 932 Série
C-E2
MT 932 Turbo Série C-E2
MT 1030 S Série 3-E2
MT 1030 S Turbo Série 3-E2

The pedal applies on the front and rear wheels by an hydraulic brake system, and allows the lift truck to be slowed down and stopped. Depending on the position of the transmission cut-off switch, it enables the free travel to cut off transmission (see: 2 - DESCRIPTION: 5 - SWITCHES PANEL).

16 - GEAR LEVER AND TRANSMISSION CUT-OFF

In order to change speeds, it is necessary to cut the transmission by pressing the button 1 on the lever.

- 1st gear: To the right, backwards.
- 2nd gear: To the right, forwards.
- 3rd gear: To the left, backwards.
- 4th gear: To the left, forwards.

USING THE GEARS ON THE GEAR BOX

- On these lift trucks with a torque converter, it is not necessary to automatically start up in 1st speed and progress up the gears.

The choice of gear ratio should be made carefully according to the nature of the work being carried out. A poor choice may result in the extremely rapid elevation of the transmission oil temperature through excessive slipping of the converter, which could lead to serious damage to the transmission (it is essential to stop and change the working conditions if the transmission oil temperature indicator light comes on). This poor choice may also result in a reduction in the lift truck's performance in forward speed. When the forward force increases, the forward speed in the g gear (for example 3rd gear) may be lower than the forward speed that could be obtained with the g-1 gear (in 2nd instead of the 3rd).



In general, we would advise you to use the following gears according to the nature of the work being carried out.

- On the road: Set off in 3rd gear and go up to 4th if the conditions and state of the road permit it. In hilly areas, set off in 2nd gear and go up to 3rd if the conditions and state of the road permit it.
- With a trailer on the road: Set off in 2nd gear and go up to 3rd if the conditions and state of the road permit it.
- Handling: 3rd gear.
2nd gear in restricted spaces.
- Loading (reclaiming with bucket, manure fork, etc.): 2nd gear.
- Earth moving: 1st gear.

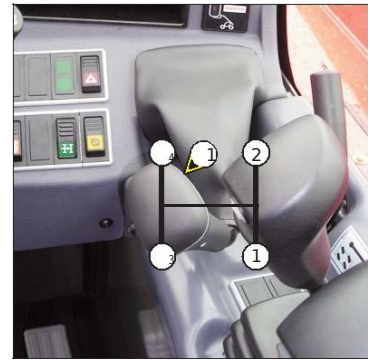

17 - REVERSING GEAR

FORWARD: Push the knob forward (position A). REVERSE: Pull the knob backwards (position B).

NEUTRAL: The knob must be in the intermediate position to start the lift truck (position C).

When operating this control, the lift truck should be travelling at slow speed and not accelerating.

NOTE: The reverse lights indicate that the lift truck is running in reverse motion. An OPTIONAL audible reversing alarm can also be fitted.

SAFETY FOR MOVING THE LIFT TRUCK

Authorization to move the lift truck is controlled by an electronic unit. The operator must observe the following sequence to move the truck forwards or backwards:

- 1 - sit down correctly in the driver's seat,
- 2 - release the parking brake,
- 3 - engage forward or reverse movement.

To stop the lift truck, he must observe the following sequence: 1 - set the reversing gear in neutral,

- 2 - engage the parking brake,
- 3 - get out of the lift truck.



NOTE: If the operator leaves the driver's cab with forward or reverse movement, an acoustic alarm sounds continuous, the operator can sit down again and to continue forward or reverse displacement. If the acoustic alarm sounds discontinuous, the operator must sit down, set the reversing gear in neutral and engage forward or reverse movement if he wants to continue the displacement.

18 - PARKING BRAKE LEVER

To prevent accidental loosening or release, the lever is fitted with safety locking.

- To apply the parking brake, pull the lever backwards (position A).
- To loosen the parking brake, release and push the lever forwards (position B).



19 - STEERING SELECTOR

Before selecting one of the three possible steering positions, bring the 4 wheels into alignment, i.e., in the straight ahead position.

A - STEERING SELECTION LEVER

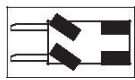

A1 - Front wheel steer (highway traffic).



A2 - Front and rear wheels steer in opposite direction (4 wheel steer).

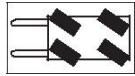

A3 - Front and rear wheels steer in the same direction (crab steer).

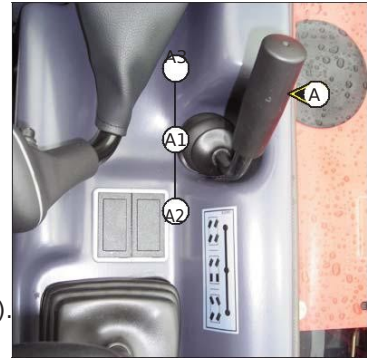

B - GREEN LAMPS FOR ALIGNMENT OF THE WHEELS

These lamps come on to indicate the alignment of the wheels, in relation to the axle of the lift truck. The lamp B1 for the front wheels and the lamp B2 for the rear wheels.

C - SWITCH FOR ALIGNMENT OF THE WHEELS

This switch enables the use or not of the device for alignment of the wheels. The indicator light indicates its use.

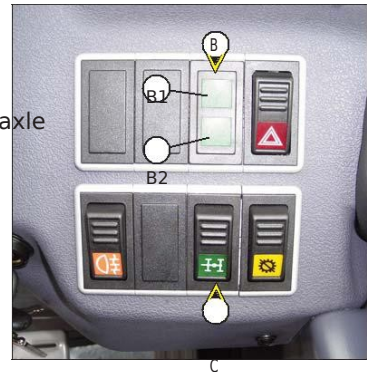

WHEEL ALIGNMENT PROCEDURE

- Connect the switch (signal light ON).
- Shift the distributor control lever for steering selection A in position A2 (4 wheel steering).
- Turn the steering wheel and bring the rear wheels into alignment until the lamp B2 is on.
- Shift the distributor control lever for steering selection A in position A1 (highway traffic).
- Turn the steering wheel and bring the front wheels into alignment until the lamp B1 is on.

⚠ Before driving on roads, it is necessary to check the alignment of the rear wheels and to drive in front wheel steer. The control of the alignment of the rear wheels must be regularly done with the help of the green lamps, while driving the lift truck. In case of anomalies, consult your dealer.

20 - HYDRAULIC CONTROLS AND TRANSMISSION CUT-OFF

Do not attempt to alter the hydraulic system pressure. In the event of suspected malfunction, contact your dealer. ANY ALTERATION MAY

 *RENDER THE WARRANTY NULL AND VOID.*

 *Use the hydraulic controls carefully without jerking, to avoid accidents caused by shaking the lift truck.*

MT 728 Série C-E2

MT 928 Série C-E2

LIFTING OF THE LOAD

- The lever A or B backwards when lifting. - The lever A or B forwards when lowering.

TILT OF THE CARRIAGE

- The lever B to the left for reverse tilt. - The lever B to the right for forward tilt.

TELESCOPING

- The lever A to the right for the extension. - The lever A to the left for the retraction.

NOTE : Only for MT 928 Série C-E2

When completely retracting the telescopes, insistently operate the control so as to allow all the telescopes to retract fully.

TRANSMISSION CUT-OFF

- Button C (see: 2 - DESCRIPTION: 5 - SWITCHES PANEL).

REVERSING GEAR

- Switch D (see: 2 - DESCRIPTION: 17 - REVERSING GEAR).

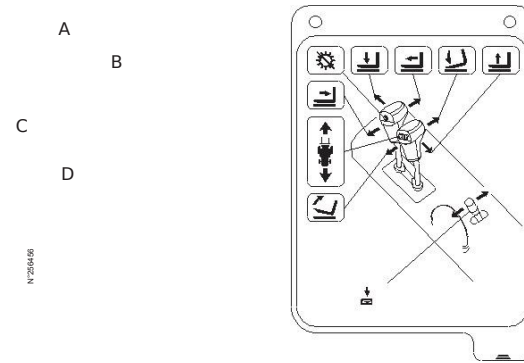

MT
 732 Série C-E2
 MT
 732 Turbo Série C-E2
 MT
 932 Série C-E2
 MT
 932 Turbo Série C-E2

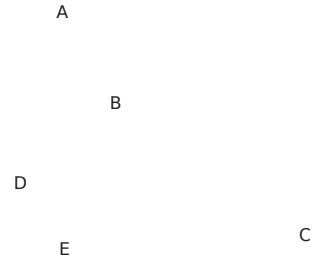

LIFTING THE LOAD

- Move lever A or B backwards to lift.

- Move lever A or B forwards to lower.

TILT OF CARRIAGE

- Move lever B to the left to excavate.

- Move lever B to the right to tip.

TELESCOPING

- Move lever A to the right to extend.

- Move lever A to the left to retract.  **NOTE: Only for MT 932 Série**

C-E2

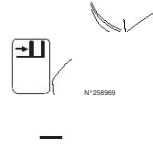

When completely retracting the telescopes, insistently operate the control so as to allow all the telescopes to retract fully.

ATTACHMENT

- Raise lever C and turn to the left or right.

TRANSMISSION CUT-OFF

- Switch D (see: 2 - DESCRIPTION: 5 - SWITCH PANEL).

REVERSING GEAR

- Switch E (see: 2 - DESCRIPTION: 17 - REVERSING GEAR).

MT 1030 S Série 3-E2
MT 1030 S Turbo Série 3-E2

LIFTING THE LOAD

- Move lever A or B backwards to lift. - Move lever A or B forwards to lower.

TILTING THE CARRIAGE

- Move the lever B to the left to excavate. - Move the lever B to the right to tip.

TELESCOPING

- Move lever A to the right to extend. - Move lever A to the left to retract.

NOTE: When completely retracting the telescopes, keep operating the control until the telescopes are fully retracted.

LEFT STABILIZER

- Move lever C forwards to lowering.
- Move lever C backwards for lifting.

RIGHT STABILIZER

- Move lever D forwards for lowering.
- Move lever D backwards for lifting.

NOTE: The stabilizers can only be raised after the jib has been retracted.

ATTACHMENT

- Raise lever E and turn to the left or right.

TRANSMISSION CUT-OFF

- Button F (see: 2 - DESCRIPTION: 5 - SWITCH PANEL).

REVERSING GEAR

- Button G (see: 2 - DESCRIPTION: 17 - REVERSING GEAR).

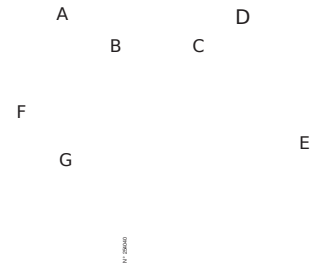

21 - LOAD CHART FILE

This file includes the description of the hydraulic controls and the load charts of the attachments used on the lift truck.

22 - HEATER CONTROL

A - HEATING FAN CONTROL

This 3-speed control regulates warm or cold air through the heating ventilators.

B - HEATING TEMPERATURE CONTROL

Allows the temperature inside the cab to be adjusted.

B1 - With the valve closed, the fan delivers fresh air.

B2 - With the valve opened completely, the fan delivers warm air. The intermediate positions allow the temperature to be adjusted.

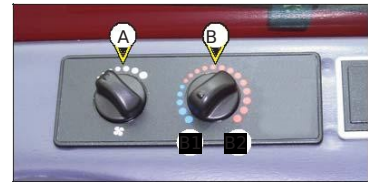

22 - AIR CONDITIONING CONTROLS (AIR CONDITIONING OPTION)

! The air conditioning only comes on when the forklift truck has been started up. When using your air conditioning, you must work with the doors and windows closed.

In winter: So as to ensure correct operation and complete efficiency of the air conditioning unit, start up the compressor once a week, if only for a short spell, so as to lubricate the internal seals.

In cold weather: Warm the I.C. engine before switching on the compressor, so as to allow the coolant that has collected in the liquid state at the lowest point of the compressor circuit to turn into gas under the effect of the heat given off by the I.C. engine, as the compressor is liable to be damaged by coolant in the liquid state.

! If your air conditioning does not seem to be working properly, have it examined by your dealer (see: 3 - MAINTENANCE: H - EVERY 2 YEARS "AIR CONDITIONING OPTION"). Never try to repair any possible problems by yourself.

DESCRIPTION OF THE AIR CONDITIONING CONTROLS

A - Air conditioning system ON/OFF control switch with indicator lamp. Only works when control switch "C" set to 1, 2 or 3. B - Air temperature control.

C - Air flow and fan speed control. When this control is set to "0" the air conditioning system will not work.

NOTE: Possible losses of water under the lift truck are due to condensate discharges caused by the drying effect of the installation, especially with high outside temperatures and high relative humidity.

For the air conditioning to perform properly, the air intakes must not be blocked by frost, snow or leaves. When the facility is running, at least one of the cab air grilles must be open so as to avoid any risk of freezing to the evaporator.

HEATING MODE

The controls must be adjusted in the following way:

- A - Control with signal light off.
- B - At the required temperature.
- C - To the desired position 1, 2 or 3.



CONDITIONED AIR MODE

The controls must be adjusted in the following way:

- A - Control with signal light on.
- B - At the required temperature.
- C - To the desired position 1, 2 or 3.

DEMISTING MODE

The controls must be adjusted in the following way:

- A - Control with signal light on.
- B - At the required temperature.
- C - To the desired position 1, 2 or 3.

NOTE: Direct the ventilators onto the cab's windows for increased efficiency.

23 - CAB FILTER VENTILATORS

See: 3 - MAINTENANCE: D - EVERY 500 HOURS SERVICE.

24 - WINDSCREEN DEMIST VENTS

For optimum effectiveness, close the heating ventilators.

25 - HEATING VENTS

These heating vents enable the air to be directed to the interior of the cabin and onto the side windows.

26 - DOOR LOCK

Two keys are provided with the lift truck to enable the cabin to be locked.

27 - LOCKING HANDLE FOR UPPER HALF DOOR

28 - RELEASING BUTTON FOR UPPER HALF DOOR

29 - HANDLE FOR REAR WINDOW OPENING

EMERGENCY EXIT

Use the rear window as an emergency exit, if it is impossible to leave the cab by the door.

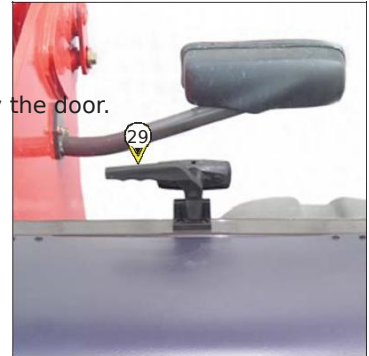

30 - TOOL BOX AND DOCUMENT HOLDER

Ensure that the operator's manual is in its place in the document holder.

NOTE: There is an OPTIONAL waterproof document holder.

31 - FRONT LIGHTS

- A - Left front indicator.
- B - Left front dipped headlight.
- C - Left front main beam.
- D - Left front sidelight.
- E - Right front indicator.
- F - Right front dipped headlight.
- G - Right front main beam.
- H - Right front sidelight.

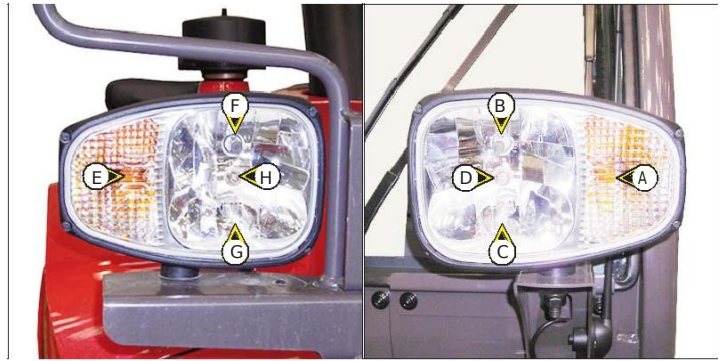

32 - REAR LIGHTS

- A - Left rear indicator.
- B - Left rear stoplight.
- C - Left tail light.
- D - Left rear reverse light.
- E - Left rear fog light.
- F - Right rear fog light.
- G - Right rear reverse light.
- H - Right tail light.
- I - Right rear stoplight.
- J - Right rear indicator.

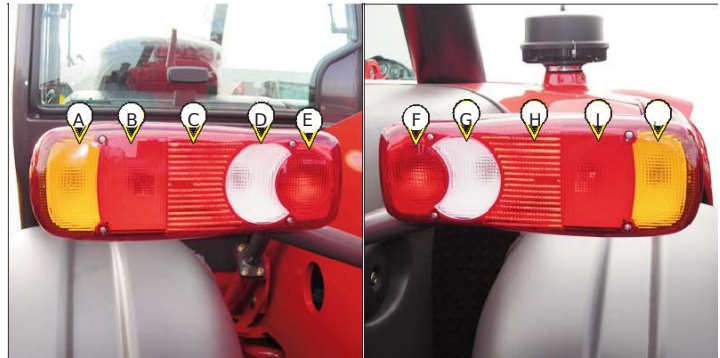

33 - REVOLVING LIGHT

The magnetic revolving light must be clearly visible on the roof of the cab and plugged-in to socket 1.



34 - DOCUMENT HOLDER NET

35 - SPIRIT LEVEL

Enables the operator to check that the lift truck is in the horizontal position.



37 - ROOF LIGHT

38 - HOOK



TOWING PIN AND HOOK

Located at the rear of the lift truck, this device is used to attach a trailer. Its capacity is limited for each lift truck by the authorised gross vehicle weight, tractive effort and maximum vertical force on the coupling point. This information is given on the manufacturer's plate fixed to each lift truck (see: 2 - DESCRIPTION: IDENTIFICATION OF THE LIFT TRUCK).

- To use a trailer, see current regulations in your country (maximum running speed, braking, maximum weight of trailer, etc.).
- Verify the trailer's condition before using it (tyre condition and pressures, electrical connection, hydraulic hose, brake system...).

⚠ *Do not tow a trailer or attachment which is not in perfect working order. Using a trailer in poor condition may affect the lift truck's steering and braking, and hence safety.*

⚠ *If a third party helps in coupling or uncoupling the trailer, this person must be permanently visible to the driver until the lift truck is parked and the I.C. engine is turned off.*

MT 732 Série C-E2
MT 732 Turbo Série
C-E2 MT 932 Série
C-E2
MT 932 Turbo Série C-E2
MT 1030 S Série 3-E2
MT 1030 S Turbo Série 3-E2

NOTE: There is an OPTIONAL rear-view mirror which allows the lift truck to be approached more closely to the trailer ring.

A - PROJECTING HOOK

STANDARD MT 1030 S Série 3-E2
MT 1030 S Turbo Série 3-E2

OPTION MT 728 Série C-E2
MT 732 Série C-E2
MT 732 Turbo Série C-E2
MT
928 Série C-E2
MT
932 Série C-E2
MT Turbo Série C-
932 E2

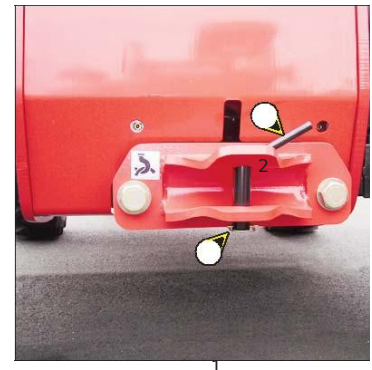

COUPLING AND UNCOUPLING THE TRAILER

- To couple the trailer, position the lift truck as close as possible to the trailer ring.
- Put the handbrake on and switch off the I.C. engine.
- Remove the clip 1, lift the trailer pin 2 and place or remove the trailer ring.

⚠ *Be careful not to get your fingers caught or crushed during this operation.
Do not forget to put clip 1 back in place.
When uncoupling, make sure that the trailer is supported independently.*

B - COUPLING LADDER (OPTIONAL)

OPTION	MT
	MT 732 Série C-E2
	MT 732 Turbo Série C-E2
	MT 932 Série C-E2
	MT 932 Turbo Série C-E2
	MT 1030 S Série 3-E2
	MT 1030 S Turbo Série 3-E2

COUPLING AND UNCOUPLING THE TRAILER

- To couple the trailer, position the lift truck as close as possible to the trailer ring.

- Put the handbrake on and switch off the I.C. engine.

ON THE FIXED PIN

- Remove pin 1, remove rod 2 and raise latch 3.

- Insert or remove the trailer ring, lower latch 3 and refit rod 2.

- ⚠ *Be careful not to get your fingers caught or crushed during this operation.*
- ⚠ *Do not forget to put clip 1 back in place.*
- When uncoupling, make sure that the trailer is supported independently.*

ON THE COUPLING LADDER

- Set the coupling fitting 4 according to the height of the trailer ring.

- ⚠ *Do not forget to put rods and clip back in place.*

- Remove pin 5, lift the towing pin 6 and insert or remove the trailer ring.

- ⚠ *Be careful not to get your fingers caught or crushed during this operation.*
- ⚠ *Do not forget to put clip 5 back in place.*
- When uncoupling, make sure that the trailer is supported independently.*



C - ELECTRICAL CONNECTION

OPTION	MT
732	MT Série C-E2
	MT 732 Turbo Série C-E2
	MT 932 Série C-E2
	MT 932 Turbo Série C-E2
	MT 1030 S Série 3-E2
	MT 1030 S Turbo Série 3-E2

- Connect the male plug to the female socket 1 on the lift truck and make sure the trailer lights work properly.



D - CONNECTING THE BRAKE SYSTEM

OPTION	MT
732	MT Série C-E2
	MT 732 Turbo Série C-E2
	MT 932 Série C-E2
	MT 932 Turbo Série C-E2
	MT 1030 S Série 3-E2
	MT 1030 S Turbo Série 3-E2

- Connect the brake hose to the provided brake unit 2 on the lift truck.

- Make sure the trailer brakes are working properly and test the effects of braking before taking the trailer onto the public highway.

DESCRIPTION AND USE OF OPTIONS

1 - REAR ELECTRIC SOCKET

MT 732 Série C-E2
MT 732 Turbo Série C-E2

MT 932 Série C-E2

MT 932 Turbo Série C-E2
MT 1030 S Série 3-E2
MT 1030 S Turbo Série 3-E2

Enables power supply connection for a trailer (see: 2 - DESCRIPTION: TOWING PIN AND

HOOK) or signalling bar.

A - Left rear indicator.

C - Earth.

D - Right rear indicator.

E - Right tail light.

F - Rear stoplight.

G - Left tail light.

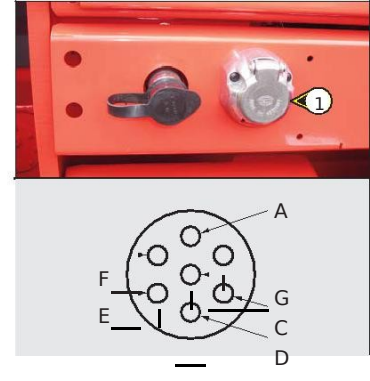

2 - BATTERY CUT-OFF

MT 732 Série C-E2
MT 732 Turbo Série C-E2
MT 932 Série C-E2
MT 932 Turbo Série C-E2
MT 1030 S Série 3-E2
MT 1030 S Turbo Série 3-E2

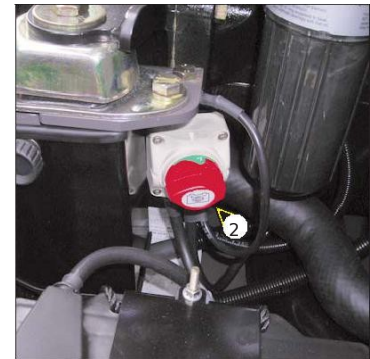

3 - NUMBER PLATE

MT
732 Série C-E2
MT
732 Turbo Série C-E2
MT
932 Série C-E2

MT
932 Turbo Série C-E2
MT

1030 S Série 3-E2
MT

1030 S Turbo Série 3-E2



4 - NUMBER PLATE LIGHTING

MT 732 Série C-E2
MT 732 Turbo Série C-E2
MT 932 Série C-E2
MT 932 Turbo Série C-E2
MT 1030 S Série 3-E2
MT 1030 S Turbo Série 3-E2

5 - PREHEATING ROD

MT 732 Série C-E2
MT 732 Turbo Série C-E2
MT 932 Série C-E2
MT 932 Turbo Série C-E2
MT 1030 S Série 3-E2
MT 1030 S Turbo Série 3-E2

Enables the motor unit to be kept warm during prolonged periods of stoppage and thus, ensures the improved start-up of the I.C. engine.

SUPPLY CHARACTERISTICS OF PREHEATING SYSTEM:

- Rated range of power: 220-240V ; 50-60Hz
- Current consumed: 4,5A
- Equipment in class 1
- Equipment connectable only on feeder circuit TT or TN
- Category of insulation 2

ENVIRONMENTAL CONDITIONS IN USE:

- Maximum ambient temperature for using preheating: + 25° C
- Pollution level 2

CONDITIONS FOR CONNECTION AND USE OF PREHEATING:

- The preheating system should not be used for an external ambient temperature higher than + 25° C.
- It is essential that the power supply to the preheating system is:
 - Effected with a cable that conforms to the installation standards in force and contains a protective earth conductor.
 - Contains an appropriate sectioning system.
 - Incorporates an appropriate safety system against short circuits (fuses or circuit breaker) and a differential circuit breaker with 30mA sensitivity.
- Only connect to and disconnect from the power supply while the unit is off and the I.C. engine is stopped.

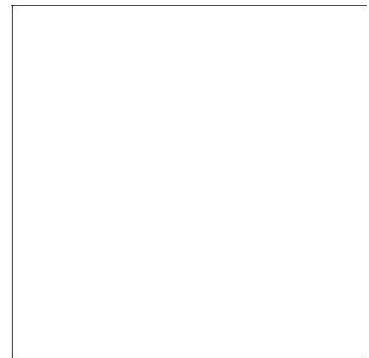
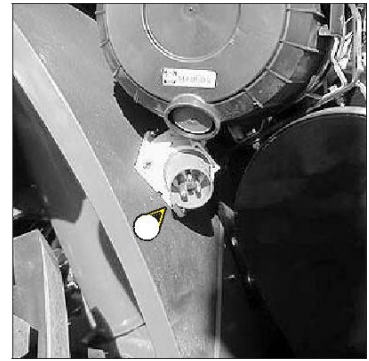

6 - DIGICODE ANTI-THEFT SYSTEM

FUNCTIONING

- Switch on the lift truck: LED A flashes red.
- Enter your user code followed by "VAL": LED A goes out.
- The entry of each figure in your code is confirmed by LED A lighting up green. If you make an error, press the "ANN" key and re-enter your code completely.
- Start the lift truck within the next 30 seconds ; otherwise the anti-theft system will react and LED A flashes red.

NOTE: You can restart the lift truck within 12 seconds of stopping it: after this time, the anti-theft system reacts and LED A flashes red.

NO
PHOTO

7 - FINTRONIC ANTI-START SYSTEM

FUNCTIONING

- Switch on the lift truck and set the black key A next to the antenna B (maximum 80 mm).
- Wait a few seconds for red LED C to go out before starting the lift truck.

NOTE: You can restart the lift truck within 20 seconds of stopping it: after this time, the anti-start system reacts and LED C flashes red.

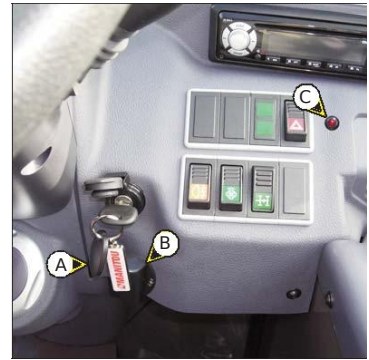

8 - PROVISION FOR ELECTRICAL JIB

Enables an electrical function to be used at the head of the jib.

MT 732 Série C-E2

MT 732 Turbo Série

C-E2 MT 932 Série

C-E2

MT 932 Turbo Série C-E2

FUNCTIONING

- Hold down button 1 and move the lever to the left or right.



MT
1030 S Série 3-E2
MT
1030 S Turbo Série 3-E2

FUNCTIONING

- Hold down button 1 and move the lever to the left or right.

1

9 - QUICK-RELEASE COUPLER ON ATTACHMENT CIRCUIT

MT 732 Série C-E2
MT 732 Turbo Série C-E2
MT 932 Série C-E2
MT 932 Turbo Série C-E2
MT 1030 S Série 3-E2
MT 1030 S Turbo Série 3-E2



10 - RETURN OF EXTERNAL LEAK

MT 732 Série C-E2
MT 732 Turbo Série C-E2
MT 932 Série C-E2
MT 932 Turbo Série C-E2
MT 1030 S Série 3-E2
MT 1030 S Turbo Série 3-E2

Enables connection of an attachment for which leak return is required.

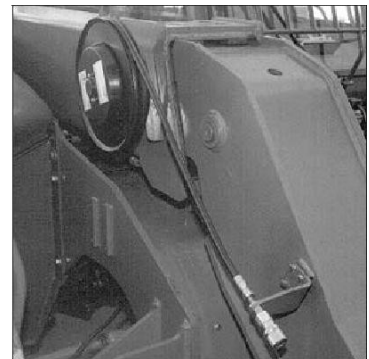

11 - HYDRAULIC ATTACHMENT LOCKING

MT 732 Série C-E2
MT 732 Turbo Série C-E2
MT 932 Série C-E2
MT 932 Turbo Série C-E2
MT 1030 S Série 3-E2
MT 1030 S Turbo Série 3-E2

Enables attachment locking to be controlled on the carriage and the use of a hydraulic attachment on the same hydraulic system (see: 4 - OPTION ATTACHMENTS ON THE RANGE: PICKING UP THE ATTACHMENTS).



12 - JIB HEAD ELECTROVALVE

Enables use of two hydraulic functions on the attachment circuit.

⚠ *To facilitate connection of the rapid connectors, release the pressure in the hydraulic system by pressing button A on the electrovalve.*

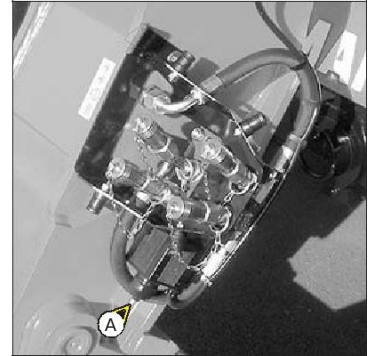

MT 732 Série C-E2
MT 732 Turbo Série C-E2
MT 932 Série C-E2
MT 932 Turbo Série C-E2

FUNCTIONING

- Without pressing Button 1, the lever controls a hydraulic function.
- Hold down button 1, the lever controls another hydraulic function.



MT 1030 S Série 3-E2
MT 1030 S Turbo Série 3-E2

FUNCTIONING

- Without pressing Button 1, the lever controls a hydraulic function.
- Hold down button 1, the lever controls another hydraulic function.



13 - JIB HEAD ELECTROVALVE + HYDRAULIC ATTACHMENT LOCKING

MT 732 Série C-E2
MT 732 Turbo Série C-E2
MT 932 Série C-E2
MT 932 Turbo Série C-E2
MT 1030 S Série 3-E2
MT 1030 S Turbo Série 3-E2

The addition of these two options enables of several hydraulic functions to be combined.



14 - N/A

15 - N/A

16 - PREARRANGED TRAILER LOCKING

MT 732 Série C-E2
MT 732 Turbo Série C-E2
MT 932 Série C-E2
MT 932 Turbo Série C-E2
MT 1030 S Série 3-E2
MT 1030 S Turbo Série 3-E2

Enables the hydraulic connection of a braked trailer (see: 2 - DESCRIPTION: TOWING PIN AND HOOK).

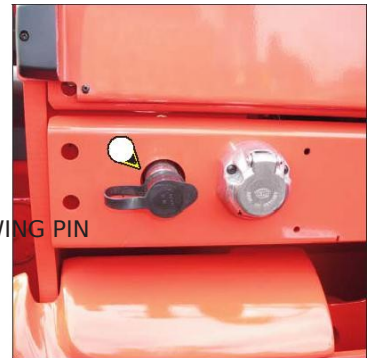

17 - CLEANFIX SELF-CLEANING FAN

MT 732 Série C-E2
MT 732 Turbo Série C-E2
MT 932 Série C-E2
MT 932 Turbo Série C-E2
MT 1030 S Série 3-E2
MT 1030 S Turbo Série 3-E2

This system, operated by switch 1, cleans the radiator core and the grille of the engine cover by reversing the air flow.

 *When in use, beware of the risk of projection into the eyes.*

Position A: The indicator light is on, the fan operates in self-cleaning mode for a few seconds once every 3 minutes.

Position B: The indicator light is off, the fan is in normal operating mode.



18 - ATTACHMENT CIRCUIT WITH QUICK-RELEASE COUPLER

MT 728 Série C-E2
MT 928 Série C-E2

Enables the use of a hydraulic attachment.

FUNCTIONING

- Raise lever 1 and turn to the left or right.

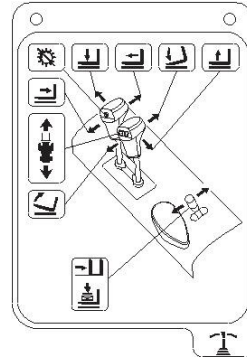

19 - N/A

MT 1030 S Série 3-E2
MT 1030 S Turbo Série 3-E2

○ TSDL

The single side-shift carriage (TSDL) is only compatible with the following attachments:

- *floating fork carriage (TFF)*
- *tilting fork carriage (PFB)*
- *loading bucket (CBR)*
- *concrete bucket (BB, BBG)*
- *spout bucket (GL)*
- *crane jib and crane jib with winch (P, PT, PO, PC)*
- *winch (H)*

It is prohibited to use any other attachments on the TSDL.

If it is being used with a loading bucket (CBR), the single side-shift carriage MUST be centred and no side-shift operations performed.

WHIT COUPLER ON JIB HEAD

A

SINGLE SIDE-SHIFT CARRIAGE

- Put the valve in position A, and used hydraulic control of the attachment of the lift truck.

ATTACHMENTS

- Put the valve in position B, and used hydraulic control of the attachment of the lift truck.

B

3 MAINTENANCE

TABLE OF CONTENTS

<i>MANITOU ORIGINAL SPARE PARTS AND EQUIPMENT</i>	<i>3 - 4</i>
<i>FILTERS CARTRIDGES AND BELTS</i>	<i>3 - 5</i>
<i>LUBRICANTS AND FUEL</i>	<i>3 - 6</i>
<i>SERVICING SCHEDULE</i>	<i>3 - 8</i>
<i>A - DAILY OR EVERY 10 HOURS SERVICE</i>	<i>3 - 10</i>
<i>B - EVERY 50 HOURS SERVICE</i>	<i>3 - 14</i>
<i>C - EVERY 250 HOURS SERVICE</i>	<i>3 - 20</i>
<i>D - EVERY 500 HOURS SERVICE</i>	<i>3 - 24</i>
<i>E - EVERY 1000 HOURS SERVICE</i>	<i>3 - 30</i>
<i>F - EVERY 2000 HOURS SERVICE</i>	<i>3 - 36</i>
<i>G - OCCASIONAL MAINTENANCE</i>	<i>3 - 38</i>
<i>H - EVERY TWO YEARS (OPTION AIR CONDITIONING)</i>	<i>3 - 42</i>

MANITOU ORIGINAL SPARE PARTS AND EQUIPMENT

OUR LIFT TRUCKS MUST BE SERVICED USING ORIGINAL MANITOU PARTS.

IF YOU USE PARTS WHICH ARE NOT ORIGINAL MANITOU PARTS,

- YOU RISK**
- Legally - to be held responsible in the event of an accident.
 - Technically - to generate operating failure or shorten the life of the lift truck.

THE USE OF COUNTERFEIT PARTS OR COMPONENTS NOT APPROVED BY THE MANUFACTURER,
MEANS YOU LOSE THE BENEFIT OF THE CONTRACTUAL GUARANTEE.

BY USING ORIGINAL MANITOU PARTS FOR MAINTENANCE OPERATIONS,

- YOU BENEFIT
EXPERTISE**
- THROUGH ITS NETWORK, MANITOU PROVIDES THE USER WITH
- Know-how and competence.
 - The guarantee of high-quality work.
 - Original replacement components.
 - Help with preventive maintenance.
 - Efficient help with diagnosis.
 - Improvements due to experience feedback.
 - Operator training.
 - Only the MANITOU network has detailed knowledge of the design of the lift truck and therefore the best technical ability to provide maintenance.

FILTERS CARTRIDGES AND BELTS

MT 728 Série C-E2
MT 732 Série C-E2
MT 928 Série C-E2
MT 932 Série C-E2
MT 1030 S Série 3-E2

I.C. ENGINE



I.C. ENGINE OIL FILTER

Part number: 476954

Change: 500 H

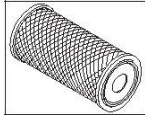

ALTERNATOR BELT

Part number: 605041



DRY AIR FILTER
CARTRIDGE
Part number: 563416

Clean: 50 H*
Change: 500 H*

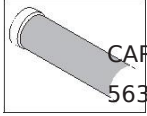

DRY AIR FILTER SAFETY
CARTRIDGE Part number:
563415 Change: 1000 H*

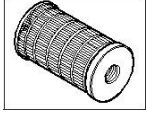

FUEL FILTER CARTRIDGE
Part number: 605013
Change: 500 H



FUEL PRE-FILTER
CARTRIDGE Part number:
706497 Change: 500 H

FAN BELT
Part number: 257525



COMPRESSOR BELT
(OPTION AIR
CONDITIONING) Part
number: 244237

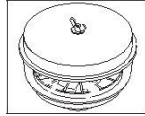

CYCLONIC PREFILTER
Part number: 224713
Clean: 10 H



AUTOMATIC VACUUM-CLEANING PRE-
FILTER (OPTION) Part number: 226611



AUTOMATIC VACUUM-CLEANING PRE-
FILTER (OPTION) Part number: 223510

*: This periodicity is given for information only (see: 3 - MAINTENANCE: SERVICING SCHEDULE) for cleaning and changing.

TRANSMISSION



TRANSMISSION OIL FILTER
Part number: 561749
Change: 500 H

HYDRAULIC

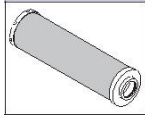

HYDRAULIC RETURN OIL FILTER CARTRIDGE
(15 μ)
Part number: 236095
Change: 500 H

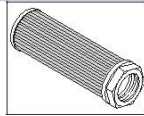

SUCTION STRAINER FOR HYDRAULIC
OIL TANK
Part number: 224726
Clean: 1000 H



FILTER CAP FOR HYDRAULIC OIL TANK
Part number: 62415
Change: 1000 H

CAB

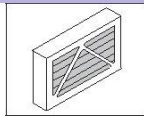
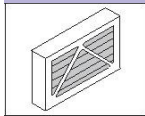

CAB VENTILATION FILTER (WITHOUT AIR
CONDITIONING) Part number: 225052
Clean: 500 H

CAB VENTILATION FILTER (WITH AIR
CONDITIONING) Part number: 225052
Clean: 50 H
Change: 250
H

LUBRICANTS AND FUEL



USE THE RECOMMENDED LUBRICANTS AND FUEL: - For topping up, oils may not be mixed.
- For oil changes, MANITOU oils are perfectly appropriate.

DIAGNOSTIC ANALYSIS OF OILS

If a service or maintenance contract has been organized with the dealer, a diagnostic analysis of engine, transmission and axle oils may be requested depending on the rate of use.

(*) FUEL CHARACTERISTICS

Use a high-quality fuel to obtain optimal performance of the I.C. engine.

RECOMMENDED FUEL SPECIFICATION:

- DERV to EN590
- BS2869 Class A2
- ASTM D975 - 91 Class 2D
- JIS K2204 (1992) Grades 1, 2, 3 and Special Grade 3.

I.C. ENGINE				
COMPONENTS	CAPACITY	RECOMMENDATION	PACKAGING	PART NUMBER
I.C. ENGINE	11.6 qt	Shell: Rotella 15w40 Citgo: C-600 15w40	5 L.	661706
			20 L.	582357
			55 L.	582358
			209 L.	582359
COOLING CIRCUIT	4.9 gal	Tulco 50/50 Premix Anti-freeze	2 L.	473076
			5 L.	470077
			20 L.	470078
			2 L.	554002
			5 L.	554003
			20 L.	554004
FUEL TANK	31.7 gal	Diesel fuel (*)		

TRANSMISSION				
COMPONENTS	CAPACITY	RECOMMENDATION	PACKAGING	PART NUMBER
TRANSMISSION	17.5 qt	Shell: Donax TG Dexron III Citgo: Transgard ATF Dexron III	1 L.	62148
			20 L.	546332
			55 L.	546217
			209 L.	546195
ANGLE GEAR BOX	2.3 qt	Shell: Spirax DH80w90 Citgo: Premim Gear MP 80w90	2 L.	499237
			20 L.	546330
			55 L.	546221
			209 L.	546220
TRANSMISSION UNIVERSAL JOINT		Shell: Rentinax Am Citgo: Lithoplex CM-2	400 g.	161589
			1 Kg.	554973
			5 Kg.	554974
			20 Kg.	499233
			50 Kg.	489670

JIB				
COMPONENTS		RECOMMENDATION	PACKAGING	PART NUMBER
JIB PADS		Shell: Rentinax Am Citgo: Lithoplex CM-2	400 g.	545996
			1 Kg.	161590
			50 Kg.	499235
GREASING OF THE JIB		Shell: Rentinax Am Citgo: Lithoplex CM-2	400 g.	161589
			1 Kg.	554973
			5 Kg.	554974
			20 Kg.	499233
			50 Kg.	489670

HYDRAULICS				
COMPONENTS	CAPACITY	RECOMMENDATION	PACKAGING	PART NUMBER
HYDRAULIC OIL TANK	33.8 gal	Shell: Tellus T46 Citgo: Transgard THF Lo-Temp	5 L.	545500
			20 L.	582297
			55 L.	546108
			209 L.	546109

BRAKE				
COMPONENTS	CAPACITY	RECOMMENDATION	PACKAGING	PART NUMBER
BRAKE CIRCUIT		Shell: Donax TG Dexron III Citgo: Transgard ATF Dexron III	1 L.	490408

CAB				
COMPONENTS	CAPACITY	RECOMMENDATION	PACKAGING	PART NUMBER
CAB DOOR		Shell: Rentinax Am Citgo: Lithoplex CM-2	400 g.	161589
			1 Kg.	554973
			5 Kg.	554974
			20 Kg.	499233
			50 Kg.	489670
WINDSCREEN WASHER TANK		Windscreen washer fluid	1 L.	490402
			5 L.	486424

FRONT AXLE				
COMPONENTS	CAPACITY	RECOMMENDATION	PACKAGING	PART NUMBER
FRONT AXLE DIFFERENTIAL*	7.7 qt	Shell: Donax TD Citgo: Transgard Tractor Hyd Fluid	5 L.	545976
			20 L.	582391
			209 L.	546222
			2 L.	499237
FRONT WHEELS REDUCERS	0.8 qt	Shell: Spirax DH80w90 Citgo: Premium Gear MP 80w9 0	20 L.	546330
			55 L.	546221
			209 L.	546220
			400 g.	545996
FRONT WHEELS REDUCERS PIVOTS		Shell: Rentinax Am Citgo: Lithoplex CM-2	1 Kg.	161590
			50 Kg.	499235

REAR AXLE				
COMPONENTS	CAPACITY	RECOMMENDATION	PACKAGING	PART NUMBER
REAR AXLE DIFFERENTIAL*	7.7 qt	Shell: Donax TD Citgo: Transgard Tractor Hyd Fluid	5 L.	545976
			20 L.	582391
			209 L.	546222
			2 L.	499237
REAR WHEELS REDUCERS	0.8 qt	Shell: Spirax DH80w90 Citgo: Premium Gear MP 80w9 0	20 L.	546330
			55 L.	546221
			209 L.	546220
			400 g.	545996
REAR WHEELS REDUCERS PIVOTS		Shell: Rentinax Am Citgo: Lithoplex CM-2	1 Kg.	161590
			50 Kg.	499235
			400 g.	161589
REAR AXLE OSCILLATION		Shell: Rentinax Am Citgo: Lithoplex CM-2	1 Kg.	554973
			5 Kg.	554974
			20 Kg.	499233
			50 Kg.	489670

* First 200 hrs: Use Manitou Special Immersed Brakes 549
Lubricant. (5 gal. drum p/n: 545608)

SERVICING SCHEDULE

A = AJUST	N = CLEAN
C = CHECK	P = BLEED
D = DESCALE	R = CHANGE
G = GREASE	V = DRAIN/CHANGE

After the first	Day or	50	250	1 year or	1 year or	2000	4000
50 hours	10 hours	hours	hours	500 hours	1000 hours	hours	hours

I.C. ENGINE									PAGE
.I.C.engineoillevel		C							3-12
.Coolingliquidlevel		C							3-12
.Fuellevel		C							3-12
.Fuelpre-filter		C							3-13
.Cyclonicprefilter		N							3-13
.Dryairfiltercartridge		C/N		R			3-16/3-27		
.Radiatorcore		N							3-16
.Condensercore(OPTIONAirconditioning)		N							3-16
.Fanbelttension		A	C/A			3-22			
.Alternator/crankshaftbelttension		A	C/A			3-22			
.Compressorbelttension(OPTIONAirconditioning)		C/A			3-23				
.I.C.engineoil		V		V			3-26		
.I.C.engineoilfilter		R		R			3-26		
.Pre-fuelfiltercartridge		R		R			3-27		
.Fuelfiltercartridge		R		R			3-28		
.Fueltank							N		3-32
.Safetydryairfiltercartridge							R		3-32
.I.C.enginesilentblocks							C**		
.I.C.enginerates							C**		
.Valvesclearances		C**			C**				
.Coolingliquid							V		3-38
.Radiator							N/D**		
.Waterpumpanthethermostat							C**		
.Alternatorandthestartermotor							C**		
.Turbocompressor							C**		
.Bleedthefuelsystem									3-40
TRANSMISSION									
.Transmissionoillevel		C							3-13
.Transmissionuniversaljoint		G		C			G/C**		3-20
.Anglegearboxoillevel		C							3-23
.Transmissionoilfilter		R		R			3-28		
.Transmissionoil		V		V			3-33		
.Transmissionhousingstrainer							N		3-33
.Anglegearboxoil		V		V			3-34		
.Transmissionsilentblocks							C**		
.Transmissioncontrols							C**		
.Transmissionpressures							C**		
.Converterpressure							C**		
TYRES									
.Tyrespressure		C							3-13
.Wheelnuttorque		C							3-13
.Conditionofwheelsandtyres							C**		
.Changeawheel									3-40
JIB									
									3-14

		<<	<<	<<	<<	<<	<<	<<
	.Jibpads	G*						
	.Jib	G						3-17
	.Jibpadswear							
	.Conditionofjibunit					C**	C**	
	.Bearingsandarticulationrings						C**	
HYDRAULIC								
	.Hydrauliccoillevel	C						3-18
	.Hydraulicreturnoilfiltercartridge	R			R			3-29
	.Balancingvalve	C			C			3-29
	.Hydrauliccoil					V		3-34
	.Suctionstrainerforhydrauliccoiltank					N		3-34
	.Filtercapforhydrauliccoiltank					R		3-34
	.Distributorcontrolheadfilter					C**		
	.Speedsofhydraulicmovements					N**		
	.Conditionofhosesandflexiblespipes		<<	<<	<<	C**		
	.Conditionofcylinders(leakage,shafts)			<<	<<	C**		
	.Hydrauliccircuitpressures						C**	
	.Hydrauliccircuitoutputs						C**	
	.Hydrauliccoiltank						N**	

3 - 8

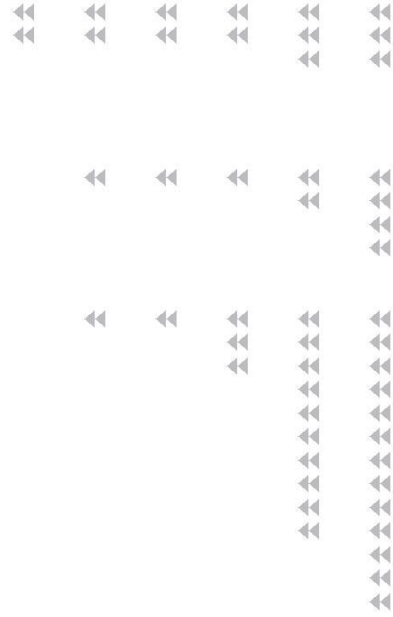

A = AJUST	N = CLEAN
C = CHECK	P = BLEED
D = DESCALE	R = CHANGE
G = GREASE	V = DRAIN/CHANGE

After the first 50 hours	Day or 10 hours	50 hours	250 hours	1 year or 500 hours	1 year or 1000 hours	2000 hours	4000 hours
-----------------------------------	--------------------------	-------------	--------------	------------------------------	-------------------------------	---------------	---------------

BRAKE

Brake oil level	C	3-18
.Parkingbrake	C/A	3-23
.Parkingbrakelevermechanism	G	3-30
.Parkingbrakemechanismonthetransmission	G**	
.Brakeoil	V**	
.Brakesystem	P**	
.Brakesystempressure	C**	
.Brake	A**	

STEERING

.Steering	C**	
.Steeringswiveljoints	C**	

CAB

.Windscreenwasherliquidlevel	C	3-19
.Cabdoor	G	3-19
.Cabventilationfilter(OPTIONAirconditioning)	N R	3-19/3-24
.Heatingblocknon-returnvalve	N	3-24
.Cabventilationfilter	N	3-30
.Seatbelt	C	3-35
.Conditionoftherearviewmirrors	C**	
.Structure	C**	
.OPTIONAirconditioning		3-46

ELECTRICITY

.Conditionofwiringharnessandcables	C**	
.Lightsandsignals	C**	
.Warningindicators	C**	
.Adjustthefrontheadlamps		3-45

FRONT AXLE

.Frontwheelsreducerspivots	G	G/C**	3-20
.Frontaxledifferentialoillevel	C		3-24
.Frontwheelsreducersoillevel	C		3-24
.Frontaxledifferentialoil	V	V	3-30
.Frontwheelsreducersoil	V	V	3-36
.Wearingofffrontaxlebrakediscs		C**	
.Frontwheelsreducersuniversaljoint		C**	
.Frontwheelsreducersclearance		C**	

REAR AXLE

Rear wheels reducers pivots	G	G/C**	3-20
.Rearaxleoscillation	G	G/C**	3-20
.Rearaxledifferentialoillevel	C		3-24
.Rearwheelsreducersoillevel	C		3-24
.RearaxledifferentialoilMT732/MT932/MT1030	V	V	3-30
.RearaxledifferentialoilMT728/MT928	V	V	3-35
.Rearwheelsreducersoil	V	V	3-36
.Wearingoffrearaxlebrakediscs		C**	
.Rearwheelsreducersuniversaljoint		C**	
.Rearwheelsreducersclearance		C**	

CHASSIS

.StabilisersMT1030S/MT1030STurbo

G

3-21

.Structure ..

C**

.Bearingsandarticulationrings

C**

ATTACHMENTS

.Forkswear ..

C**

.Attachmentcarriage ..

C**

.Conditionofattachments ..

C**

LIFT TRUCK

.Towtheliftruck ..

3-41

.Slingtheliftruck ..

3-41

.Transporttheliftruckonaplatfom

3-43

(*): Every 10 hours during the first 50 hours, then once at 250 hours.

(**): Consult your dealer.

3 - 9

*A - DAILY OR EVERY 10 HOURS
SERVICE*

A1 - I.C. ENGINE OIL LEVEL

CHECK

Place the lift truck on level ground with the I.C. engine stopped, and let the oil drain into the sump.

- Open the I.C. engine bonnet.
- Remove the dipstick 1 (fig. A1).
- Clean the dipstick and check the correct level between the two notches.
- If necessary, add oil (see: 3 - MAINTENANCE: LUBRICANTS AND FUEL) by the filler port 2 (fig. A1).
- Check visually that there is no leakage or seepage of oil in the I.C. engine.

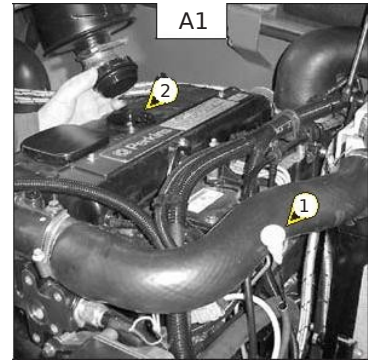

A2 - COOLING LIQUID LEVEL

CHECK

Place the lift truck on level ground with the I.C. engine stopped, and allow the I.C. engine to cool.

- Open the I.C. engine bonnet.
- Check the correct level in the middle of gauge 1 (fig. A2/1).
- If necessary, add cooling liquid (see: 3 - MAINTENANCE: LUBRICANTS AND FUEL).
- Slowly turn the cap of the radiator 2 (fig. A2/1) anticlockwise up to the safety stop.
- Allow the pressure and vapour to escape.
- Press down and turn the cap so as to release the cap.
- Add cooling liquid via filler port 3 (fig. A2/1) up to the middle of gauge 1 (fig. A2/1).
- Lubricate slightly the filler neck in order to facilitate the setting and the removal of the radiator cap.
- Check visually that there is no leakage in the radiator and pipes.

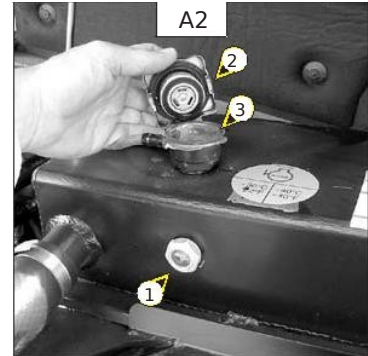

! To avoid any risk of spraying or burning, wait until the I.C. engine has cooled down before removing the cooling circuit filler plug. If the cooling liquid is very hot, add only hot cooling liquid (80°C). In an emergency, you can use water as a cooling liquid, then change the cooling circuit liquid as soon as possible (see: 3 - MAINTENANCE: F1 - COOLING LIQUID).

A3 - FUEL LEVEL

CHECK

Keep the fuel tank full, to reduce as much as possible any condensation due to the atmospheric conditions.

- Remove cap 1 (fig. A3).
- Fill the fuel tank with clean fuel (see: 3 - MAINTENANCE: LUBRICANTS AND FUEL), filtered through a strainer or a clean, lint free cloth, through filler port 2 (fig. A3).
- Put the cap back 1 (fig. A3).
- Check visually that there is no leakage in the tank and pipes.

! Never smoke or approach with a flame during filling operations or when the tank is open. Never refill while I.C. engine is running.

! The fuel tank is vented via the filler plug. When changing it, always use an original part, with vent hole.

MT 732 Série C-E2 / MT 732 Turbo Série C-E2
MT 932 Série C-E2 / MT 932 Turbo Série C-E2
MT 1030 S Série 3-E2 / MT 1030 S Turbo Série 3-E2

NOTE: A locking tank cap is available as an OPTION.

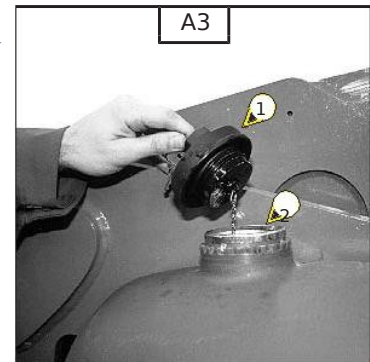

A4 - FUEL PRE-FILTER

CHECK

- Pull on the handle located inside the cab to open the engine hood.
- Check for the presence of water in the pre-filter bowl 1 (fig. A4) and empty it out if necessary.
- Place a receptacle under the drain plug 2 (fig. A4) and loosen it in two to three thread turns.
- Allow the diesel fuel to flow out until it is free from impurities and water.
- Retighten the drain plug while the diesel fuel is flowing out.

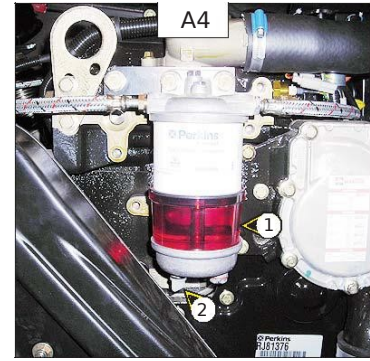

A5 - CYCLONIC PREFILTER

CLEAN

The cleaning interval is given as a guide, however the prefilter must be emptied as soon as impurities reach the MAX. level on the tank.

- Loosen nut 1 (fig. A5), remove cover 2 (fig. A5) and empty the tank.
- Clean the prefilter unit with a clean dry cloth and reassemble the unit.

▲ When cleaning, take care not to let impurities into the dry air filter.

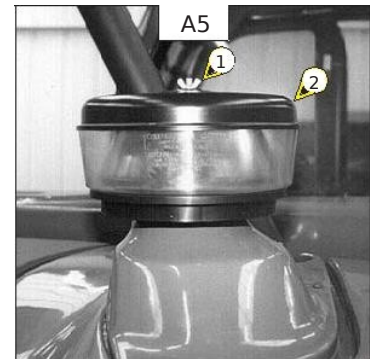

A6 - TRANSMISSION OIL LEVEL

CHECK

1

A6

Park the lift truck on level ground with the jib raised, the I.C. engine cold and stopped.

Carry out the control within 5 minutes of the I.C. engine being stopped.

- Remove the plastic cap 1 (fig. A6).
- Remove the dipstick 2 (fig. A6).
- Wipe the dipstick and check the correct level between the two MIN and MAX marks.
- If necessary, add oil (see: 3 - MAINTENANCE: E3 - TRANSMISSION OIL).
- Check visually that there is no leakage or seepage of oil in the transmission.

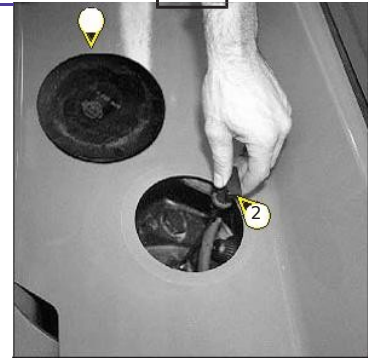

A7 - TYRES PRESSURE AND WHEEL NUTS TORQUE

CHEC
K

- Check the condition of the tyres, to detect cuts, protuberances, wear, etc.
- Check the torque load of the wheel nuts. Non compliance with this instruction can cause damage and rupture to the wheel bolts and distortion to the wheels.

Wheel nuts tightening torque

- Front tyres: 465 ft/lb
- Rear tyres: 465 ft/lb

- Check and adjust the tyre pressures if necessary (see: 2 - DESCRIPTION: CHARACTERISTICS).

⚠ *Check that the air hose is correctly connected to the tyre valve before inflating and keep all persons at a distance during inflation. Respect the recommended tyre pressures given.*

NOTE: There is an OPTIONAL wheel toolkit.

A8 - JIB PADS

CLEAN - GREASE

To be carried out every 10 hours during the first 50 hours service, then once at 250 hours.

- Extend the jib completely.
- With a brush, apply a coat of grease (see: 3 - MAINTENANCE: LUBRICANTS AND FUEL) on the 4 sides of the telescope(s) (fig. A8).
- Telescope the jib several times in order to spread the coat of grease evenly.
- Remove the surplus of grease.

If the lift truck is used in an abrasive environment (dust, sand, coal...) Use lubricating varnish (MANITOU reference: 483536). In this respect, consult

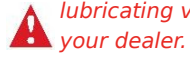

your dealer.

MT 732 Série C-E2 / MT 732 Turbo Série C-E2

MT 932 Série C-E2 / MT 932 Turbo Série C-E2

MT 1030 S Série 3-E2 / MT 1030 S Turbo Série 3-E2

NOTE: A jib sealing kit is available as an OPTION.

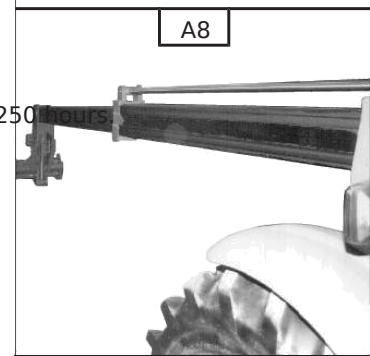

EVERY 50 HOURS SERVICE

Carry out the operations described previously as well as the following operations.

B1 - DRY AIR FILTER CARTRIDGE

*CHECK -
CLEAN*

In case of use in a heavily dust laden atmosphere, there are pre-filtration cartridges (see: 3 - MAINTENANCE: FILTERS CARTRIDGES AND BELTS). Also, the checking and cleaning periodicity of the cartridge must be reduced.

! *If the clogging indicator light comes on, this operation must be carried out as quickly as possible (1 hour maximum). The cartridge must not be cleaned more than seven times, after which the cartridge must be changed. Never use the lift truck without an air filter or with a damaged air filter.*

- For the disassembly and reassembly of the cartridge, see: 3 - MAINTENANCE: D3 - DRY AIR FILTER CARTRIDGE.
- Clean the filter cartridge using a compressed air jet (max. pressure 3 bar) directed from the top to the bottom and from the inside towards the outside at a minimum distance of 30 mm from the cartridge wall.
- Cleaning is completed when there is no more dust on the cartridge.

! *Respect the safety distance of 30 mm between the air jet and the cartridge to avoid tearing or making a hole in the cartridge. The cartridge must not be blown anywhere near the air filter box. Never clean the cartridge by tapping it against a hard surface. Your eyes must be protected during this intervention.*

- Clean the cartridge seal surfaces with a damp, clean lint-free cloth and grease with a silicone lubricant.

- Check visually the outer condition of the air filter and its mounts. Verify the condition of the hoses and their mounts also.

! *Never clean the dry air filter cartridge by washing it in liquid. Do not clean by any means the safety cartridge located inside the filter cartridge, change it for a new one if it is clogged or damaged.*

B2 - RADIATOR CORE

CLEAN

! *In a polluting atmosphere, clean the radiator core every day. Do not use a water jet or high-pressure steam as this could damage the radiator fins.*

- Open the I.C. engine bonnet.
- If necessary, clean the suction grid on the engine bonnet.
- Using a soft cloth, clean the radiator in order to remove as much dirt as possible.
- Clean the radiator using a compressed air jet aimed in the same direction as the cooling air flow (fig. B2).

NOTE: So as to enhance the cleaning, carry out this operation with the fan running.

MT 732 Série C-E2 / MT 732 Turbo Série C-E2
MT 932 Série C-E2 / MT 932 Turbo Série C-E2
MT 1030 S Série 3-E2 / MT 1030 S Turbo Série 3-E2

NOTE: An OPTIONAL straw deflector and self-cleaning fan can also be fitted.

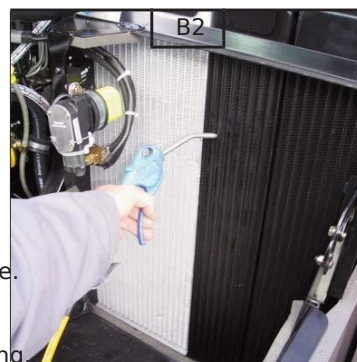

B3 - CONDENSER CORE (AIR CONDITIONING OPTION)

CHECK -
CLEAN

In a polluting atmosphere, clean the radiator core every day. Do not use a water jet or high-pressure steam as this could damage the radiator fins.

- !** - Remove the protective grid 1 (fig. B3) and clean it if necessary.
- Visually check whether the condenser 2 (fig. B3) is clean and clean it if necessary.
- Clean the condenser using a compressed air jet aimed in the same direction as the air flow.

NOTE: So as to enhance the cleaning, carry out this operation with the fan running.

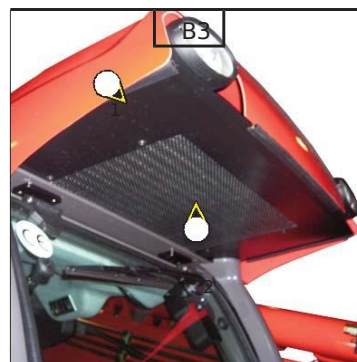

B4 - JIB

GREASE

To be carried out weekly, if the lift truck has been operated for less than 50 hours during the week.

⚠ In the event of prolonged use in an extremely dusty or oxidising atmosphere, reduce this interval to 10 working hours or every day.

Clean and lubricate the following points with grease (see: 3 - MAINTENANCE: LUBRICANTS AND FUEL) and remove the surplus of grease.

- 1 - Lubricators of the jib axle (2 lubricators) (fig. B4/1).
- 2 - Lubricators of the carriage axle (2 lubricators) (fig. B4/2).
- 3 - Lubricator of the tilt cylinder foot axle (1 lubricator) (fig. B4/3).
- 4 - Lubricator of the tilt cylinder head axle (1 lubricator) (fig. B4/4).
- 5 - Lubricator of the lifting cylinder foot axle (1 lubricator) (fig. B4/5).
- 6 - Lubricator of the lifting cylinder head axle (1 lubricator) (fig. B4/6).
- 7 - Lubricator of the compensation cylinder foot axle (1 lubricator) (fig. B4/5).
- 8 - Lubricator of the compensation cylinder head axle (1 lubricator) (fig. B4/7).

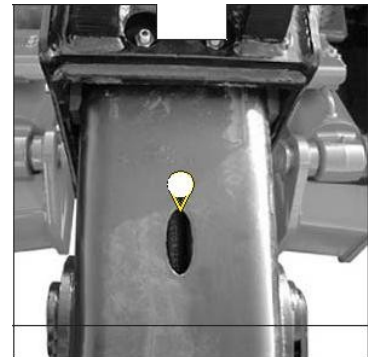
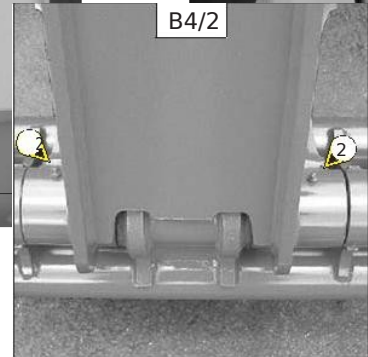
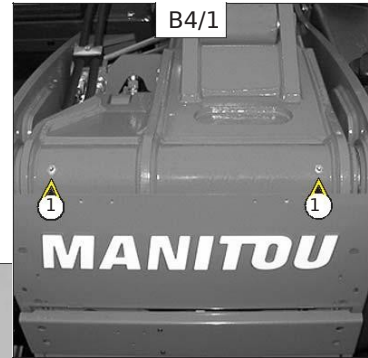

B4/3

3

.....MT728/MT732

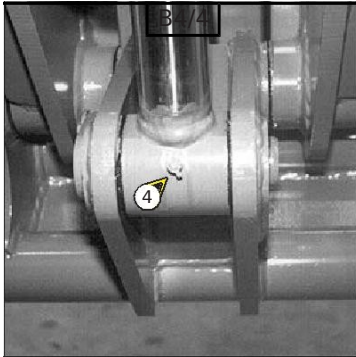

B4/3

3

.....MT928/MT932

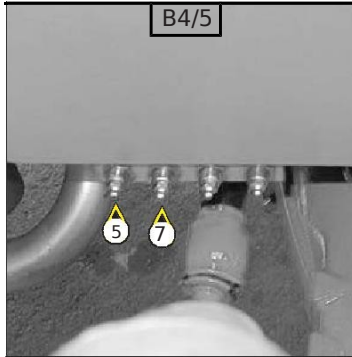

B4/3

3

...MT1030S

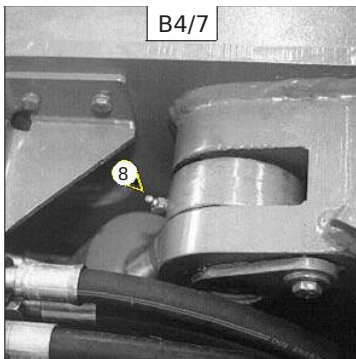
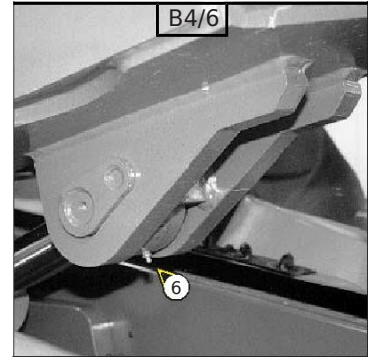

B5 - HYDRAULIC OIL LEVEL

CHECK

Place the lift truck on level ground with the I.C. engine stopped, and the jib retracted and lowered as far as possible.

- Refer to gauge 1 (fig. B5/1).
- The oil level is correct when it is at the level of the red point.
- If necessary, add oil (see: 3 - MAINTENANCE: LUBRICANTS AND FUEL).
- Remove cap 2 (fig. B5/2).
- Add oil by filler port 3 (fig. B5/2).

▲ Use a clean funnel and clean the underside of the oil drum before filling.

- Put the cap back.
- Check visually that there is no leakage in the tank and pipes.

Always maintain the oil level at maximum as cooling depends on the oil flowing through the tank.

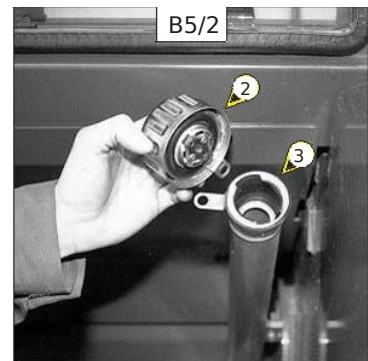
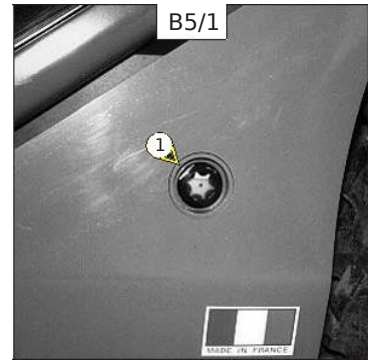

B6 - BRAKE OIL LEVEL

CHECK

Place the lift truck on level ground.

- Loosen screw 1 (fig. B6/1) and remove the access panel for braking oil tank and windscreen washer tank 2 (fig. B6/1).
- The level is correct when it is at the MAX. level on the tank.
- If necessary, add oil (see: 3 - MAINTENANCE: LUBRICANTS AND FUEL) by the filler port 3 (fig. B6/2).
- Turn the tank to unscrew the filler plug
- Check visually that there is no leakage in the tank and pipes.

▲ in the event of an abnormal drop in oil level, consult your dealer.



B7 - WINDSCREEN WASHER LIQUID LEVEL

CHECK

- Loosen screw 1 (fig. B7/1) and remove the access panel for braking oil tank and windscreen washer tank 2 (fig. B7/1).
- Check visually the level.
- If necessary add windscreen washer liquid (see: 3 - MAINTENANCE: LUBRICANTS AND FUEL) by filler port 3 (fig. B7/2).

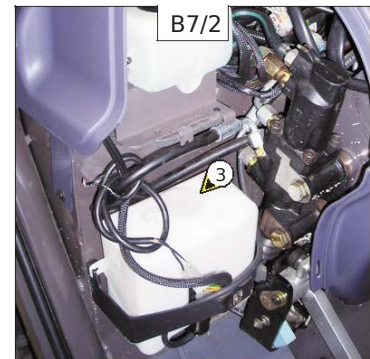
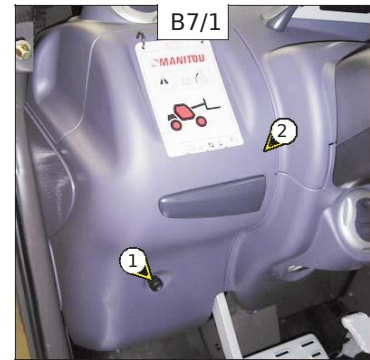

G
R
C
I

B8 - CAB DOOR

GREASE

B
8

1

Clean and lubricate the points 1 (4 lubricators) (fig. B8) with grease (see: 3 - MAINTENANCE: LUBRICANTS AND FUEL) and remove the surplus of grease.

1

B
G
R
C
I

B9 - CAB VENTILATION FILTER (OPTION AIR CONDITIONING)

CLEAN

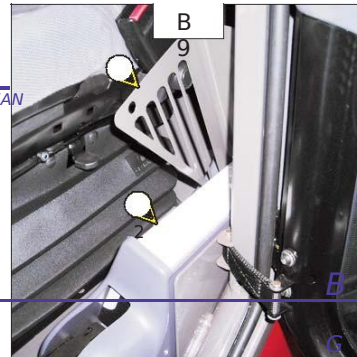

- Lift up protective casing 1 (fig. B9).
- Lift out cabin ventilation filter 2 (fig. B9).
- Clean the filter with a compressed air jet.
- Check its condition and change if necessary (see: 3 - MAINTENANCE: FILTERS CARTRIDGES AND BELTS).
- Refit the filter and protective casing.

B
G
R
C
I
1

- 1 - Lubricators of the universal joint I.C. engine/Angle gear box (2 lubricators) (fig. B12/1).

- 2 - Lubricators of the univ

universal joint Transmission/Rear axle (3 lubricators) (fig. B12/3).

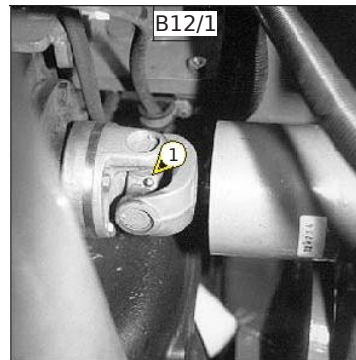
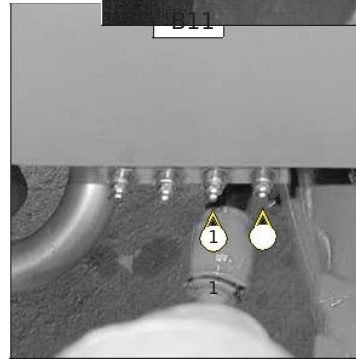
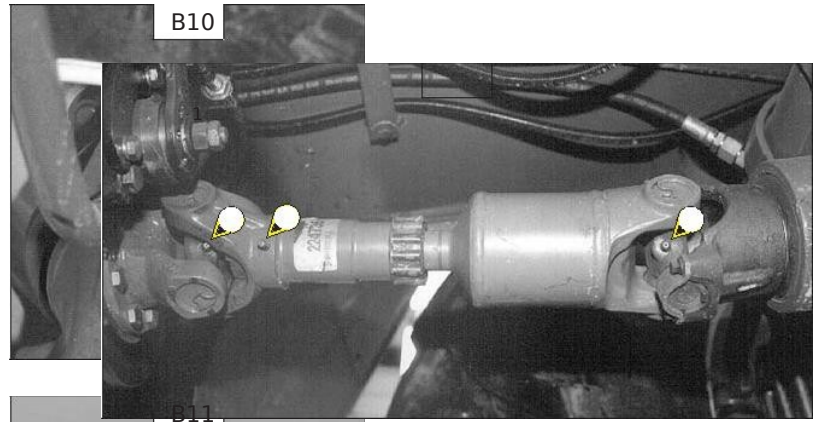

B12/2

2 2

2

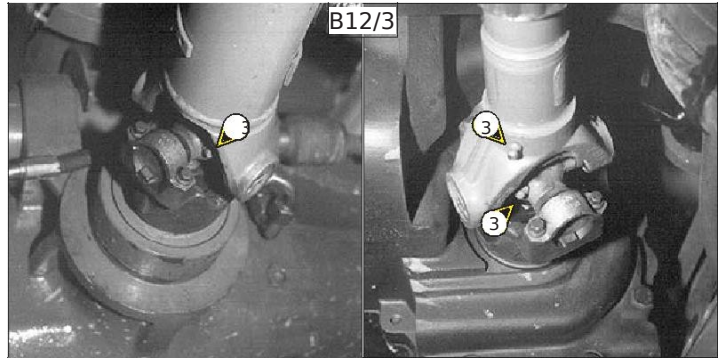

3 - 18

B13 - STABILISERS

GREASE

B13/1

MT

1030 S Série 3-E2

MT

1030 S Turbo Série 3-E2

1

Clean and lubricate the following points with grease (see: 3 - MAINTENANCE: LUBRICANTS AND FUEL) and remove the surplus of grease.

1

1 - Lubricators on stabiliser actuator shafts (4 lubricators) (fig. B13/1).

2 - Lubricators on stabiliser actuator shafts (4 lubricators) (fig. B13/2 and B13/3).

C - EVERY 250 HOURS SERVICE

Carry out the operations described previously as well as the following operations.

C1 - FAN BELT TENSION

CHECK - ADJUST

- Open the I.C. engine bonnet.
- Check the belt for signs of wear and cracks and change if necessary (see: 3 - MAINTENANCE: FILTERS CARTRIDGES AND BELTS).
- Loosen screw 1 (fig. C1/1) on the tension pulley.
- Loosen lock nut 2 (fig. C1/1 and C1/2) and screw 3 (fig. C1/1 and C1/2).
- Bring the belt just into contact with pulley 4 (fig. C1/1) (on the lift truck, check this operation by feel).
- Make a mark on the head of screw 3 (fig. C1/1 and C1/2) and tighten, turning it 5 times.
- Tighten the lock nut 2 (fig. C1/1 and C1/2).

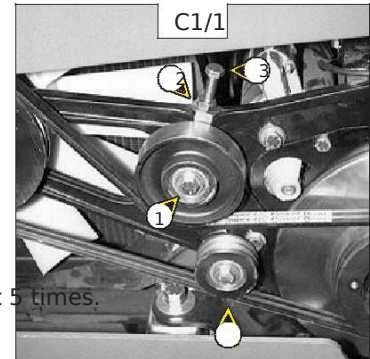

- Retighten screw 1 (fig. C1/1) on the tension pulley.

When changing the fanbelt, tighten screw 3 (fig. C1/1 and C1/2) by one and a half turns,

 having allowed the I.C. engine to idle for 30 minutes.

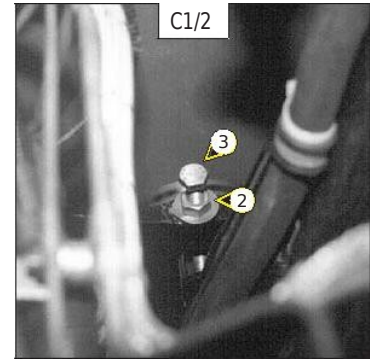

C2 - ALTERNATOR/CRANKSHAFT BELT TENSION

CHECK - ADJUST

- Open the I.C. engine bonnet.
- Unscrew the fastening screws 1 (fig. C2/1).
- Lay down the protective guard 2 (fig. C2/1).
- Check the belt for signs of wear and cracks and change if necessary (see: 3 - MAINTENANCE: FILTERS CARTRIDGES AND BELTS).
- Check the belt tension between the pulleys of the crankshaft and of the alternator.
- Under a normal pressure exerted with the thumb (10 ft/lb), the tension should be approximately 3/8 in.
- Carry out adjustments if necessary.
- Untighten screws 3 (fig. C2/2) by two to three thread turns.
- Swivel the alternator assembly so as to obtain the belt tension required.
- Retighten screws 3 (fig. C2/2) (tightening torque 16 ft/lb).
- Put the protective guard back 2 (fig. C2/1).

If the alternator belt has to be changed, check the tension again after the first 20 hours

 of operation.

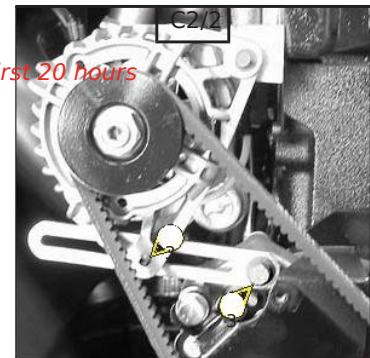
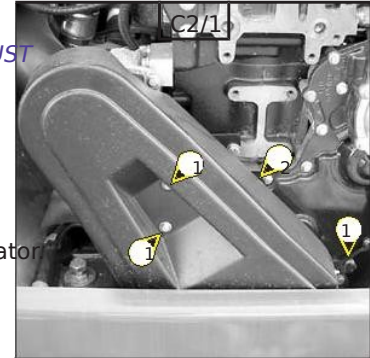

C3 - COMPRESSOR BELT TENSION (OPTION AIR CONDITIONING)

CHECK - ADJUST

3 - 21

- Open the I.C. engine bonnet.
- Unscrew the fastening screws 1 (fig. C3/1).
- Lay down the protective guard 2 (fig. C3/1).
- Check the belt for signs of wear and cracks and change if necessary (see: 3 - MAINTENANCE: FILTERS CARTRIDGES AND BELTS).
- Check the belt tension between the pulleys of the crankshaft and of the compressor.
- Under a normal pressure exerted with the thumb (10 ft/lb), the tension should be approximately 3/8 in.
- Carry out adjustments if necessary.
- Untighten screws 3 (fig. C3/2) by two to three thread turns.
- Swivel the compressor assembly so as to obtain the belt tension required.
- Retighten screws 3 (fig. C3/2).
- Put the protective guard back 2 (fig. C3/1).

 *If the compressor belt has to be changed, check the tension again after the first 20 hours of operation.*

C4 - ANGLE GEAR BOX OIL LEVEL

CHECK

Park the lift truck on level ground with the jib raised and the I.C. engine stopped.

- Remove level plug 1 (fig. C4).
- Wipe the dipstick and check the correct level between the MINI and MAXI marks.
- If necessary, add oil (see: 3 - MAINTENANCE: E5 - ANGLE GEAR BOX OIL).

C5 - PARKING BRAKE

CHECK - ADJUST

Place the lift truck on a slope less than 15 % with the rated load in the transport position.

- Check the tightening adjustment by locking the parking brake in position A (fig. C5).
- The adjustment is correct when the lift truck is held stationary on a slope.
- Carry out adjustments if necessary.
- Press and release the brake pedal, then release the parking brake, putting it in position B (fig. C5).
- Progressively tighten the end piece of the lever 1 (fig. C5) and recheck braking.
- Repeat the operation until the correct braking adjustment is obtained.

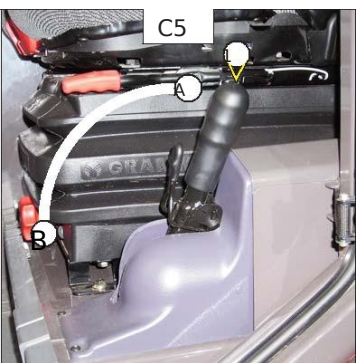
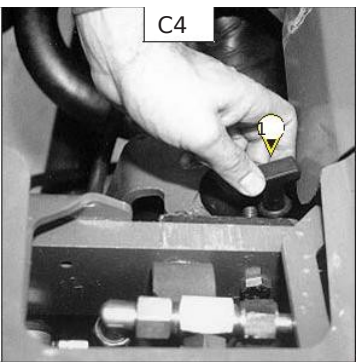
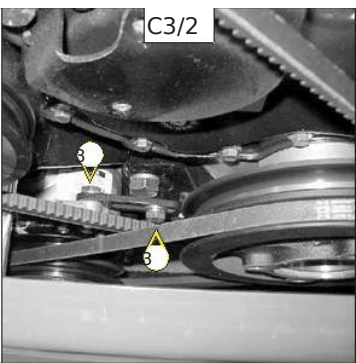
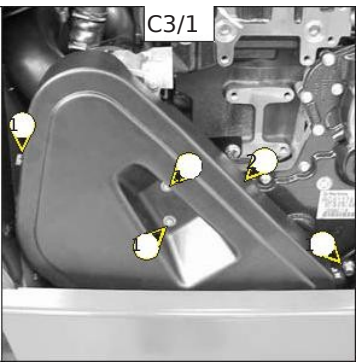

C6 - CAB VENTILATION FILTER (OPTION AIR CONDITIONING)

CHANGE

- Lift up protective casing 1 (fig. C6).
- Lift out cabin ventilation filter 2 (fig. C6) and fit new replacement filter (see: 3 - MAINTENANCE: FILTERS CARTRIDGES AND BELTS).
- Refit the protective casing.

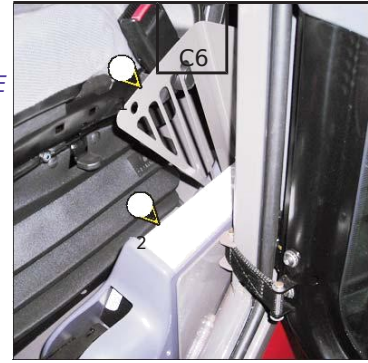

C7 - HEATING BLOCK NON-RETURN VALVE

CLEAN

- Since non-return valve 1 (fig. C7) is located under the cab, it is possible for it to become obstructed with spattered mud for example. Clean if necessary.

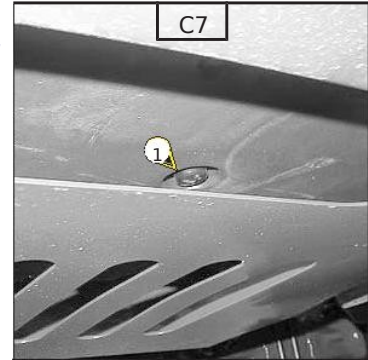

C8 - FRONT AND REAR AXLE DIFFERENTIAL OIL LEVEL

CHECK

Place the lift truck on level ground with the I.C. engine stopped.

- Remove level plug 1 (fig. C8). The oil should be flush with the edge of the hole.
- If necessary, add oil (see: 3 - MAINTENANCE: LUBRICANTS AND FUEL) by the filler port 2 (fig. C8).
- Replace and tighten the level plug 1 (fig. C8) (tightening torque 30 ft/lb).
- Repeat this operation for the rear axle differential.

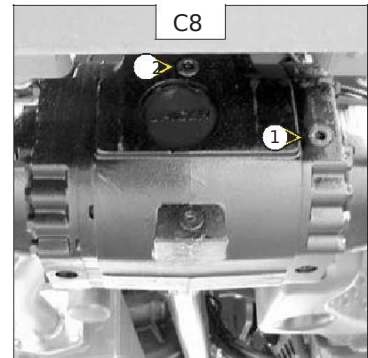

C9 - FRONT AND REAR WHEELS REDUCERS OIL LEVEL

CHECK

Place the lift truck on level ground with the I.C. engine stopped.

- Check the level on each front wheel reducer.
- Place level plug 1 (fig. C9) in the horizontal position.
- Remove the level plug ; the oil should be flush with the edge of the hole.
- If necessary, add oil (see: 3 - MAINTENANCE: LUBRICANTS AND FUEL) by the same hole.
- Replace and tighten the level plug 1 (fig. C9) (tightening torque 30 ft/lb).
- Repeat the same operation on each rear wheel reducer.

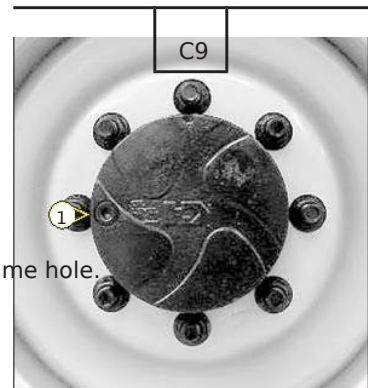

D - EVERY 500 HOURS SERVICE

Carry out the operations described previously as well as the following operations.

D1 - I.C. ENGINE OIL

D2 - I.C. ENGINE OIL FILTER

CHANGE

Place the lift truck on level ground, let the I.C. engine run at idle for a few minutes, then stop the I.C. engine.

DRAINING THE OIL

- Open the I.C. engine bonnet.
- Remove access panel 1 (fig. D1/1).
- Place a container under drain plug 2 (fig. D1/2) and unscrew the plug 3 (fig. D1/3).
- Take drain hose 4 (fig. D1/4).
- Place the end of the drain hose in the container and screw fully the union on draining port 5 (fig. D1/5).
- Remove filler cap 6 (fig. D1/6) in order to ensure that the oil is drained properly.

 *Dispose of the drain oil in an ecological manner.*

REPLACEMENT OF THE FILTER

- Remove I.C. engine oil filter 7 (fig. D1/3) ; discard the filter and the filter seal.
- Clean the filter bracket with a clean, lint-free cloth.
- Lightly grease the new oil filter seal and refit the oil filter (see: 3 - MAINTENANCE: FILTERS CARTRIDGES AND BELTS) on the filter bracket.

 *Tighten the oil filter by hand pressure only and lock the filter in place by a quarter turn.*

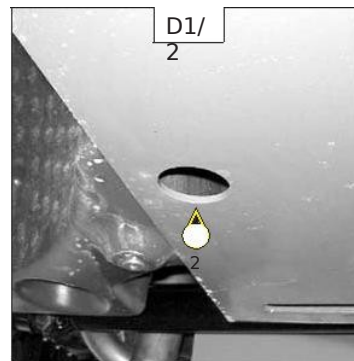
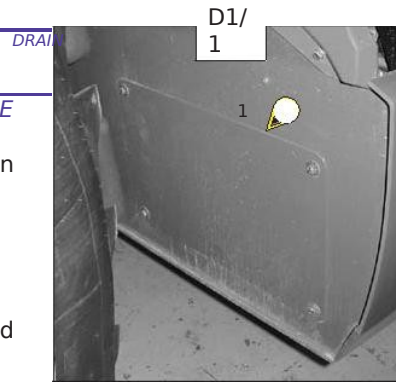

FILLING UP THE OIL

- Loosen, clean and put back in place the drain hose 4 (fig. D1/4).
- Refit and tighten drain plug 3 (fig. D1/3).
- Refit access panel 1 (fig. D1/1).
- Fill up with oil (see: 3 - MAINTENANCE: LUBRICANTS AND FUEL) by filler port 8 (fig. D1/6).
- Wait a few minutes to allow the oil to flow into the sump.
- Start the I.C. engine and let it run for a few minutes.
- Check for possible leaks at the drain plug and the oil filter.
- Stop the I.C. engine, wait a few minutes and check the level between the two notches on dipstick 9 (fig. D1/6).
- Top up the level if necessary.

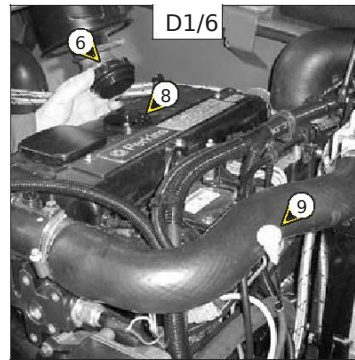
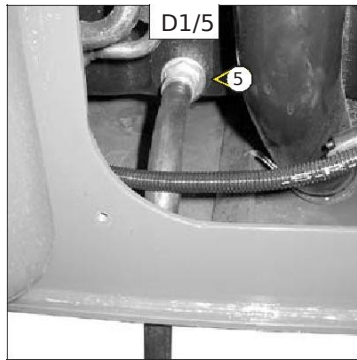
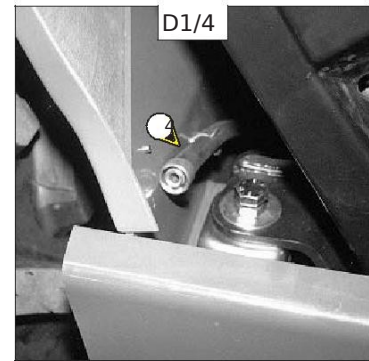
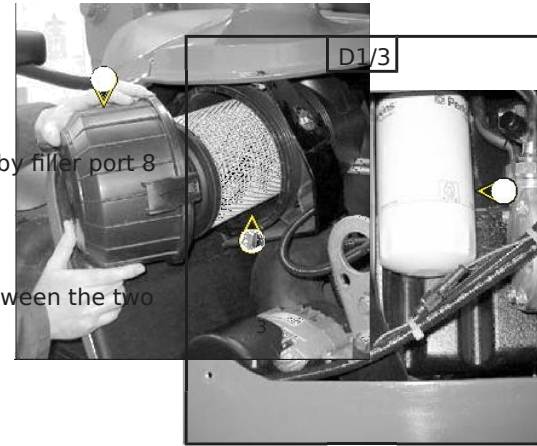

3 - 24

D3 - DRY AIR FILTER CARTRIDGE

D3

CHANGE

1

In case of use in a heavily dust laden atmosphere, there are pre-filtration cartridges, see: 3 - MAINTENANCE: FILTERS CARTRIDGES AND BELTS. Also, the checking and cleaning periodicity of the cartridge must be reduced (up to 250 hours in a heavily laden dust atmosphere and with pre-filtration).



Change the cartridge in a clean location, with the I.C. engine stopped. Never run the I.C. engine

with the air filter removed or damaged.

- Open the I.C. engine bonnet.
- Loosen the bolts and remove cover 1 (fig. D3).
- Gently remove the cartridge 2 (fig. D3), taking care to avoid spilling the dust.
- Leave the safety cartridge in place.
- The following parts must be cleaned with a damp, clean lint-free cloth.
 - The inside of the filter and cover.
 - The inside of the filter inlet hose.
 - The gasket surfaces in the filter and in the cover.

- Check pipes and connections between the air filter and the I.C. engine and the condition and state of the clogging indicator on the filter.

- Before mounting check the state of the new cartridge (see: 3 - MAINTENANCE: FILTERS CARTRIDGES AND BELTS).

- Introduce the cartridge into the filter axis and push it in, pressing the edges and not the middle.

- Reassemble the cover, guiding the valve downwards.

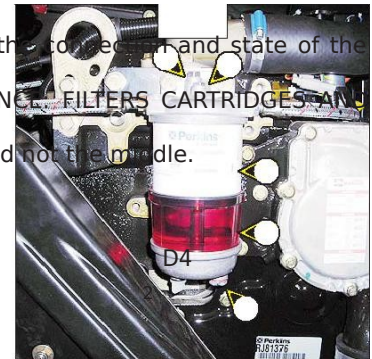

D4 - FUEL PRE-FILTER CARTRIDGE

CHANGE

Make sure the electrical contact on the lift truck is cut, otherwise fuel will be released if the lift pump is powered up.

- Pull on the handle located inside the cab to open the engine hood. 5
- Carefully clean the outside of the filter and its holder, to prevent dust from getting into the system. 4
- Place a container under the pre-filter and drain it using drain plug 1 (fig. D4). 1
- Remove bleeder screw 2 (fig. D4) in order to ensure that the oil is drained properly.
- Unscrew locking screw 3 (fig. D4).
- Remove container 4 (fig. D4) and discard cartridge 5 (fig. D4) as well as its seals.
- Clean the inside of the filter head and the housing, using a brush immersed in clean diesel oil.
- Refit the assembly with a new cartridge and new seals (see: 3 - MAINTENANCE: FILTERS CARTRIDGES AND BELTS).
- If necessary, bleed the fuel circuit (see: 3 - MAINTENANCE: G1 - FUEL SYSTEM).

 *Make sure the electrical contact on the lift truck is cut, otherwise fuel will be released if the lift pump is on.*

- Open the I.C. engine bonnet.
- Carefully clean the outside of the filter and its holder, to prevent dust from getting into the system.
- Place a container under the filter and drain it via drain plug 1 (fig. D5/1).
- Loosen the body of filter 2 (fig. D5/1).
- Remove the filter cartridge by pressing the cartridge 3 (fig. D5/2) down against the pressure of the spring and turn it to the left to extract it.
- Insert a new cartridge (see: 3 - MAINTENANCE: FILTERS CARTRIDGES AND BELTS), by pressing the cartridge 3 (fig. D5/2) down against the pressure of the spring and turn it to the right to lock it into the body of the filter.
- Place the new seal 4 (fig. D5/2) onto the body of the filter and lubricate the contact surface using clean engine oil.
- Remount the body of the filter onto its holder, hand-tighten it only and lock it with a quarter-turn.
- Close drain plug 1 (fig. D5/1) and remove the container.
- Before starting the I.C. engine, leave the ignition on for three minutes on the lift truck, to give the lift pump time to release air from the filter.
- Start up the I.C. engine and make sure there is no leakage.
- If necessary, bleed the fuel circuit (see: 3 - MAINTENANCE: G1 - FUEL SYSTEM).

D6 - TRANSMISSION OIL FILTER

- Remove the cover plate 1 (fig. D6/1).
- Unscrew and discard the transmission oil filter 2 (fig. D6/2).
- Carefully clean the filter head with a clean, lint-free cloth.
- Slightly lubricate the new seal and fit the seal on the filter.
- Fill up the new transmission oil filter (see: 3 - MAINTENANCE: FILTERS CARTRIDGES AND BELTS) with oil (see: 3 - MAINTENANCE: LUBRICANTS AND FUEL).
- Refit the filter, making sure that the seal is correctly positioned and tightened.

 *Tighten the transmission oil filter by hand pressure only and lock the filter in place by a quarter turn.*

- Put back the cover plate 1 (fig. D6/1).



2

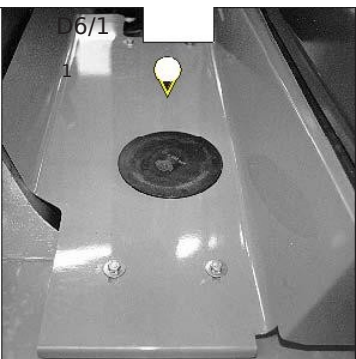
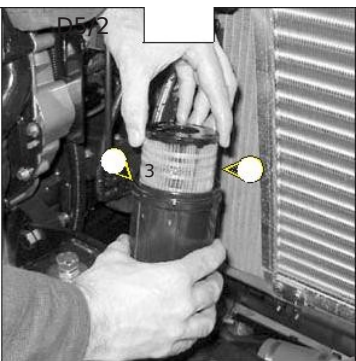

D7 - HYDRAULIC RETURN OIL FILTER CARTRIDGE

CHANGE

Stop the I.C. engine and remove the pressure from the circuits by acting on the hydraulic controls.

⚠ *Thoroughly clean the outside of the filter and its surroundings before any intervention in order to prevent any risk of polluting the hydraulic circuit.*

- Place a container under hydraulic drain filter 1 (fig. D7).
- Unscrew the body of the filter.
- Remove the hydraulic return oil filter cartridge and fit new replacement cartridge (see: 3 - MAINTENANCE: FILTERS CARTRIDGES AND BELTS).
- Make sure that the cartridge is correctly positioned and refit the body of the filter.

⚠ *Tighten the body of the filter by hand pressure only and lock the body of the filter in place by a quarter turn.*

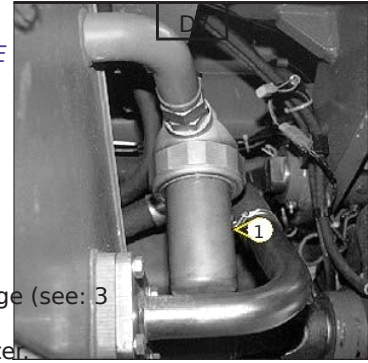

D8 - BALANCING VALVE

CHECK

To be performed after the first 50 hours of operation and then every 500 hours.
Stop the lift truck on horizontal ground, put the handbrake on and set the reverse gear to neutral.

ROLE OF BALANCING VALVES

- The balancing valves protect the user from any risk due to a fall in hydraulic pressure or an exploding hose during hydraulic operations.

⚠ *Keep everyone well away during these inspections.
In all cases, the balancing valve(s) concerned must be repaired or replaced if hydraulic movement continues after the I.C. engine has been switched off.
Never use the lift truck with a defective balancing valve.*

TESTING EACH HYDRAULIC MOVEMENT

LIFTING CIRCUIT:

- Start up the lift truck and raise the jib by about 45°.
- With the I.C. engine running at mid- speed, lower the jib. While the jib is being lowered, switch off the I.C. engine; movement should slow down as the I.C. engine speed falls and stop when the I.C. engine stops.

TELESCOPING CIRCUIT:

- Start up the lift truck and raise the jib as far as it will go, extending the telescope(s) completely.
- With the I.C. engine running at mid- speed, retract the telescope(s). When retracting the jib, switch off the I.C. engine; movement should slow down as the I.C. engine speed falls and stop when the I.C. engine stops.

TILT CIRCUIT:

- Place the nominal load on the forks, anchor it correctly to prevent it from falling off during the test.
- Start up the lift truck and tilt the carriage backwards, lifting the jib sufficiently to allow the carriage to tilt.
- With the I.C. engine running at mid-speed, tilt the carriage forwards. While it is tilting, switch off the I.C. engine; movement should slow down as the I.C. engine speed falls and stop when the I.C. engine stops.

D9 - PARKING BRAKE LEVER MECHANISM

GREASE

- Clean and grease articulation axles 1 (fig. D9) with grease (see: 3 - MAINTENANCE: LUBRICANTS AND FUEL).

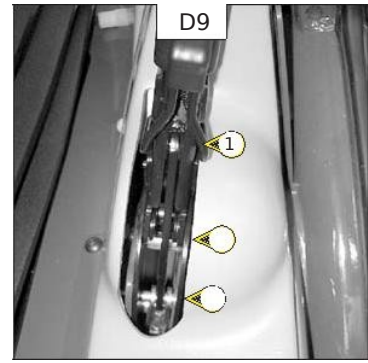

D10 - CAB VENTILATION FILTER

CLEAN

- Lift up protective casing 1 (fig. D10).
- Lift out cabin ventilation filter 2 (fig. D10).
- Clean the filter with a compressed air jet.
- Check its condition and change if necessary (see: 3 - MAINTENANCE: FILTERS CARTRIDGES AND BELTS).
- Refit the filter and protective casing.

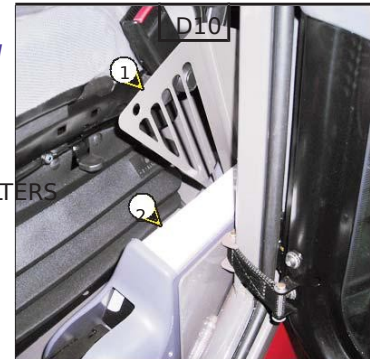

D11 - FRONT AXLE DIFFERENTIAL OIL

DRAIN

Place the lift truck on level ground with the I.C. engine stopped and the differential oil still warm.

⚠ *Dispose the drain oil in an ecological manner.*

- Place a container under drain plugs 1 (fig. D11) and unscrew the plugs.
- Remove level plug 2 (fig. D11) and filler plug 3 (fig. D11) in order to ensure that the oil is drained properly.
- Refit and tighten drain plugs 1 (fig. D11) (tightening torque 30 ft/lb).
- Fill up with oil (see: 3 - MAINTENANCE: LUBRICANTS AND FUEL) by filler port 3 (fig. D11).
- The level is correct when the oil level is flush with the edge of port 2 (fig. D11).
- Check for any possible leaks at the drain plugs.
- Refit and tighten level plug 2 (fig. D11) (tightening torque 30 ft/lb) and filler plug 3 (fig. D11) (tightening torque 30 ft/lb).

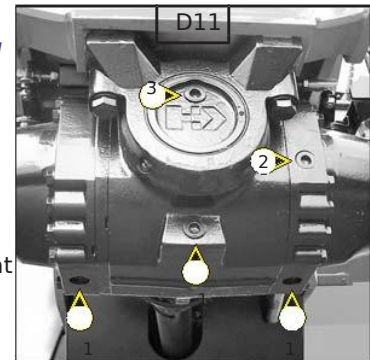

D12 - REAR AXLE DIFFERENTIAL OIL

DRAIN

MT 732 Série C-E2 / MT 732 Turbo Série C-E2
 MT 932 Série C-E2 / MT 932 Turbo Série C-E2
 MT 1030 S Série 3-E2 / MT 1030 S Turbo Série 3-E2

Place the lift truck on level ground with the I.C. engine stopped and the differential oil still warm.

⚠ *Dispose the drain oil in an ecological manner.*

- Place a container under drain plugs 1 (fig. D12) and unscrew the plugs.
- Remove level plug 2 (fig. D12) and filler plug 3 (fig. D12) in order to ensure that the oil is drained properly.
- Refit and tighten drain plugs 1 (fig. D12) (tightening torque 30 ft/lb).
- Fill up with oil (see: 3 - MAINTENANCE: LUBRICANTS AND FUEL) by filler port 3 (fig. D12).
- The level is correct when the oil level is flush with the edge of port 2 (fig. D12).
- Check for any possible leaks at the drain plugs.
- Refit and tighten level plug 2 (fig. D12) (tightening torque 30 ft/lb) and filler plug 3 (fig. D12) (tightening torque 30 ft/lb).

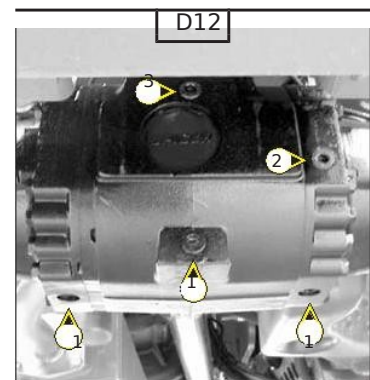

E - EVERY 1000 HOURS SERVICE

Carry out the operations described previously as well as the following operations.

E1 - FUEL TANK

CLEA
N

⚠ While carrying out these operations, do not smoke or work near a flame.

Place the lift truck on level ground with the I.C. engine stopped.

- Inspect the parts susceptible to leaks in the fuel circuit and in the tank.
- In the event of a leak, contact your dealer.

⚠ Never try to carry out a weld or any other operation by yourself, this could provoke an explosion or a fire.

- Place a container under drain plug 1 (fig. E1/1) and unscrew the plug.
- Remove cap 2 (fig. E1/2).
- Let the fuel flow and clean with 10 liters of clean fuel by filler port 3 (fig. E1/2).
- Refit and tighten drain plug 1 (fig. E1/1) (tightening torque 26 ft/lb).
- Fill the fuel tank with clean fuel (see: 3 - MAINTENANCE: LUBRICANTS AND FUEL) filtered through a strainer or a clean, lint-free cloth and refit the filler plug 2 (fig. E1/2).
- If necessary, bleed the fuel circuit (see: 3 - MAINTENANCE: G1 - FUEL SYSTEM).

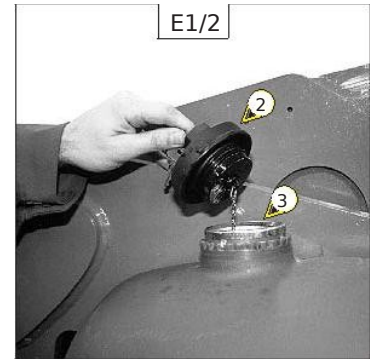
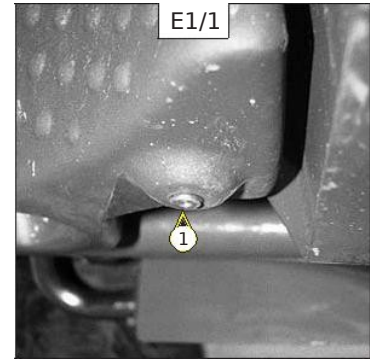

E2 - SAFETY DRY AIR FILTER CARTRIDGE

CHANGE

- For the disassembly and reassembly of the cartridge, see: 3 - MAINTENANCE: D3 - DRY AIR FILTER CARTRIDGE.
- Gently remove the dry air filter safety cartridge 1 (fig. E2), taking care to avoid spilling the dust.
- Clean the gasket surface on the filter with a damp, clean lint-free cloth.
- Before mounting check the state of the new safety cartridge (see: 3 - MAINTENANCE: FILTERS CARTRIDGES AND BELTS).
- Introduce the cartridge into the filter axis and push it in, pressing the edges and not the middle.

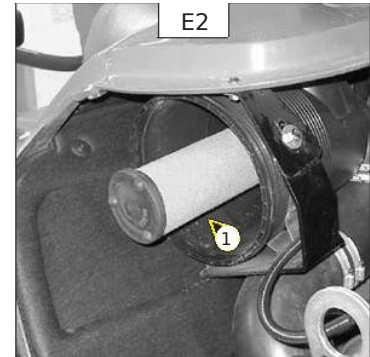

NOTE: The periodicity for changing the safety cartridge is given for information only. The safety cartridge must be changed for every two changes of the air filter cartridge.

E4 - TRANSMISSION HOUSING STRAINER

Place the lift truck on level ground with the I.C. engine stopped, the transmission oil still warm.

DRAINING THE OIL

- Place a container under drain plug 1 (fig. E3/1) and under cover 2 (fig. E3/2) and unscrew the drain plug.
- Remove cover plate 3 (fig. E3/3).
- Remove dipstick 4 (fig. E3/4) and unscrew filling plug 5 (fig. E3/4) in order to ensure that the oil is drained properly.



Dispose the drain oil in an ecological manner.

CLEANING THE STRAINER

- Remove cover 2 (fig. E3/2) and set aside the O-ring joint and sealing washer.
- Allow the rest of the oil to drain away.
- Remove and clean the strainer using a compressed air jet.
- Clean the magnetic section on the plate.
- Refit the assembly and tighten up plate 2 (fig. E3/2) (tightening torque 18 ft/lb).

FILLING UP THE OIL

- Refit and tighten drain plug 1 (fig. E3/1) (tightening torque 32 ft/lb).
- Fill up with oil (see: 3 - MAINTENANCE: LUBRICANTS AND FUEL) by filler port 5 (fig. E3/4) and refit the plug.
- Start the I.C. engine and let it run for a few minutes.
- Check any possible leaks from the drain plug or cover.
- Stop the I.C. engine, and within 5 minutes of the I.C. engine being stopped, check on the dipstick 4 (fig. E3/4) the correct level between the two MIN and MAX marks.
- Top up the level if necessary.
- Put back the cover plate 3 (fig. E3/3).

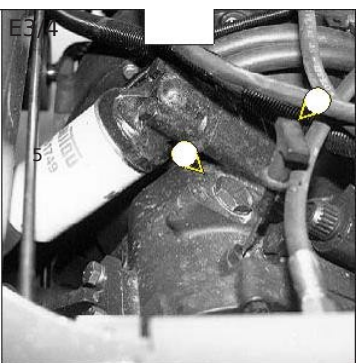
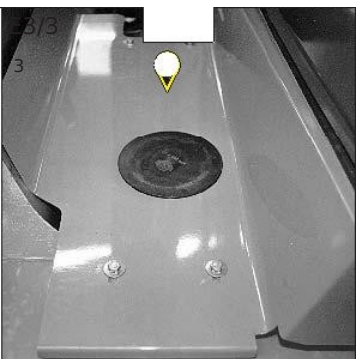
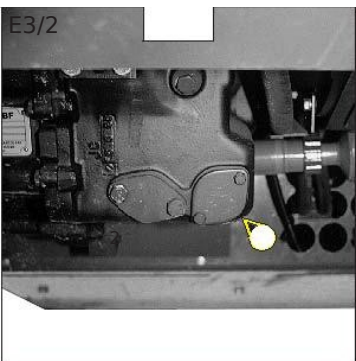
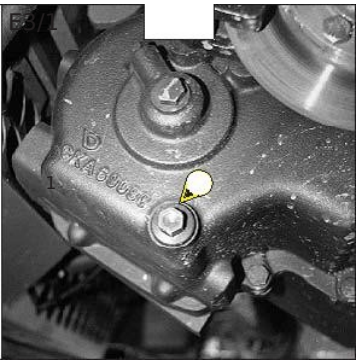

E5
-
AN
GL
E
GE
AR
BO
X
OIL

E
5

-R
e

-F
i

-C
h

-C
h

DRAIN

Place the lift truck on level ground with the I.C. engine stopped, the angle gear box oil still warm.

- Place a container under drain plug 1 (fig. E5/1) and unscrew the plug.
- Remove dipstick 2 (fig. .

E5/1

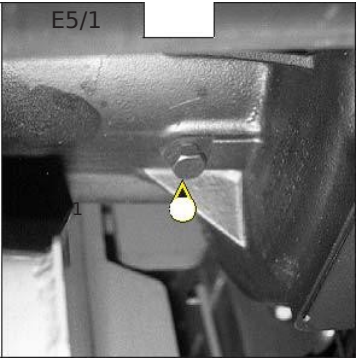

E5/2

2

3

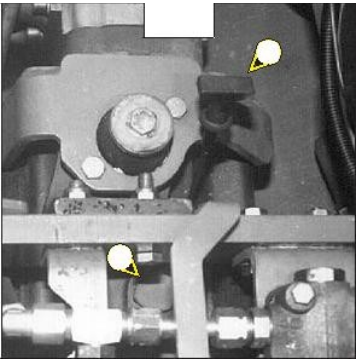

E
6 - HYDRAULIC OIL

DRAIN

E6/1

E
7 - SUCTION STRAINER FOR HYDRAULIC OIL TANK

CLEAN

E
8 - FILTER CAP FOR HYDRAULIC OIL TANK

CHANGE

Place the lift truck on level ground with the I.C. engine stopped and telescope jib retracted and lowered as far as possible.

⚠ Before any intervention, thoroughly clean the area surrounding the drain plugs and the suction cover on the hydraulic tank.

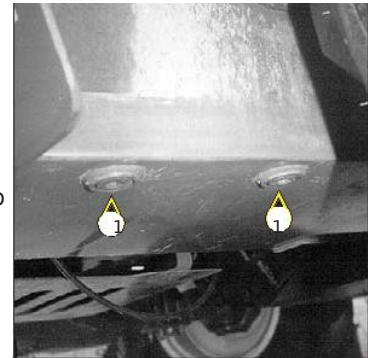

DRAINING THE OIL

- Place a container under drain plug 1 (fig. E6/1) and unscrew the plug.
- Remove filler cap 2 (fig. E6/2) in order to ensure that the oil is drained properly.

▲ *Dispose of the drain oil in an ecological manner.*

CLEANING THE STRAINER

- Remove suction cover 3 (fig. E6/3).
- Remove and clean the strainer using a compressed air jet, check its condition and replace if necessary (see: 3 - MAINTENANCE: FILTERS CARTRIDGES AND BELTS).
- Refit the strainer and tighten the suction cover 3 (fig. E6/3) (tightening torque 60 ft/lb) making sure the seal is in the correct position.

FILLING UP THE OIL

- Clean and refit drain plugs 1 (fig. E6/1) (tightening torque 25 ft/lb).
- Fill up with oil (see: 3 - MAINTENANCE: LUBRICANTS AND FUEL) by filler port 4 (fig. E6/2).

▲ *Use a clean container and funnel and clean the underside of the oil drum before filling.*

- Observe the oil level on dipstick 5 (fig. E6/4), the oil level should be at the level of the red point.
- Check for any possible leaks at the drain plugs.
- Replace filler plug 2 (fig. E6/2) with a new filler plug (see: 3 - MAINTENANCE: FILTERS CARTRIDGES AND BELTS).

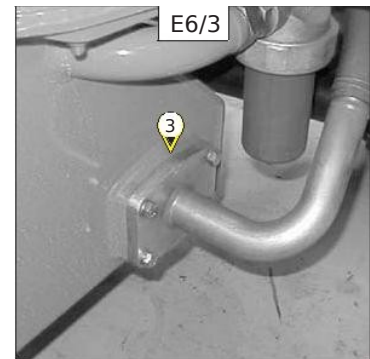
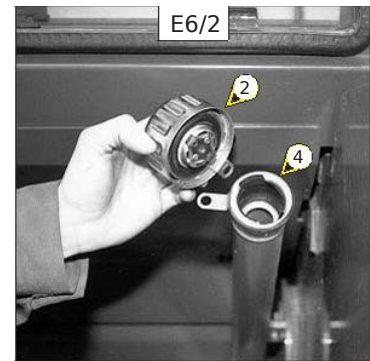

HYDRAULIC CIRCUIT DECONTAMINATION

- Let the I.C. engine run (accelerator pedal at halfway travel) for 5 minutes without using anything on the lift truck, then for 5 more minutes while using completely the hydraulic movements (except the steering system and the service brakes).
- Accelerate the I.C. engine at full speed for 1 minute, then activate the steering system and the service brakes.
- This operation makes a pollution abatement of the circuit possible through the hydraulic return oil filter.

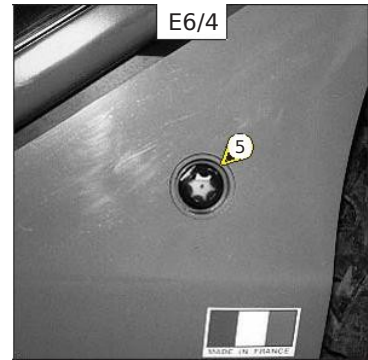

E9 - SEAT BELT

CHECK

SEAT BELT WITH TWO ANCHORING POINTS

- Check the following points:
 - Fixing of the anchoring points on the seat.
 - Cleanness of the strap and the locking mechanism.
 - Triggering of the locking mechanism.
 - Condition of the strap (cuts, curled edges).

REELED BELT WITH TWO ANCHORING POINTS

- Check the points listed above together with the following points:
 - The correct winding of the belt.
 - Condition of the reel guards.
 - Roller locking mechanism when the strap is given a sharp tug.

NOTE: After an accident, replace the seat belt.

 *Under no circumstances should you use the lift truck if the seat belt is faulty (fixing, locking, it has cuts or tears, etc). Repair or replace the seat belt immediately.*

E10 - N/A

	E10	
- REAR AXLE DIFFERENTIAL OIL	3	
	<i>DRAIN</i>	
MT 728 Série C-E2		2
MT 928 Série C-E2		
Place the lift truck on level ground with the I.C. engine stopped and the differential oil still warm.		
<i>Dispose the drain oil in an ecological manner.</i>	1	1
- Place a container under drain plugs 1 (fig. E10) and unscrew the plugs.	1	1
- Remove level plug 2 (fig. E10) and filler plug 3 (fig. E10) in order to ensure that the oil is drained properly.		
- Refit and tighten drain plugs 1 (fig. E10) (tightening torque 30 ft/lb).		
- Fill up with oil (see: 3 - MAINTENANCE: LUBRICANTS AND FUEL) by filler port 3 (fig. E10).		
- The level is correct when the oil level is flush with the edge of port 2 (fig. E10).		
- Check for any possible leaks at the drain plugs.		
- Refit and tighten level plug 2 (fig. E10) (tightening torque 30 ft/lb) and filler plug 3 (fig. E10) (tightening torque 30 ft/lb).		

E11 - FRONT AND REAR WHEELS REDUCERS OIL

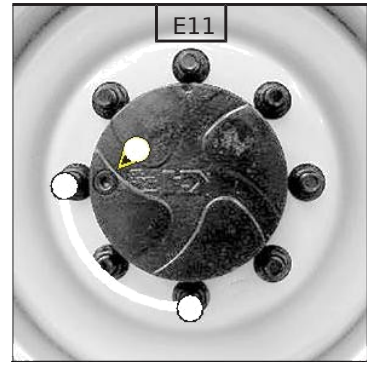



Place the lift truck on level ground with the I.C. engine stopped and the reducers oil still warm.

B

Dispose the drain oil in an ecological manner.

- Drain and change each front wheel reducer. - Place drain plug 1 (fig. E11) in position A.
- Place a container under the drain plug and unscrew the plug.
- Let the oil drain fully.
- Place the drain port in position B, i.e. in a level port.
- Fill up with oil (see: 3 - MAINTENANCE: LUBRICANTS AND FUEL) by level port 1 (fig. E11). - The level is correct when the oil level is flush with the edge of the hole.
- Refit and tighten the drain plug 1 (fig. E11) (tightening torque 30 ft/lb). - Repeat this operation on each rear wheel reducer.

A

F - EVERY 2000 HOURS SERVICE

Carry out the operations described previously as well as the following operations.



F1 - COOLING LIQUID

DRAI
N

These operations are to be carried out if necessary or every two years at the beginning of winter. Place the lift truck on level ground with the I.C. engine stopped and cold.

DRAINING THE LIQUID

- Open the I.C. engine bonnet.
- Remove the shroud 1 (fig. F1/1).
- Set a container under drain valve 2 (fig. F1/2) on the radiator and drain plug 3 (fig. F1/3) of the engine block and loosen them.
- Remove filler cap 4 (fig. F1/4) of the radiator.
- Let the cooling circuit drain entirely while ensuring that the ports do not get clogged.
- Check the condition of the hoses as well as the fastening devices and change the hoses if necessary.
- Rinse the circuit with clean water and use a cleaning agent if necessary.

FILLING THE LIQUID

- Tighten the drain valve 2 (fig. F1/2) and drain plug 3 (fig. F1/3) (tightening torque 30 ft/lb).
- Slowly fill up the circuit with cooling liquid (see: 3 - MAINTENANCE: LUBRICANTS AND FUEL) to the middle of gauge 5 (fig. F1/4) through filler port 6 (fig. F1/4).
- Put back filler cap 4 (fig. F1/4).
- Run the I.C. engine at idle for a few minutes.
- Check for any possible leaks.
- Put back the shroud 1 (fig. F1/1)
- Check the level and refill if necessary.

The I.C. engine does not contain any corrosion resistor and must be filled during the whole year with a mixture containing 25 % of ethylene glycol-based antifreeze.

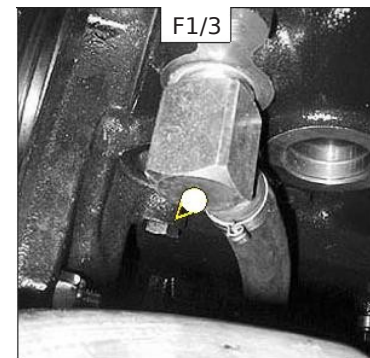
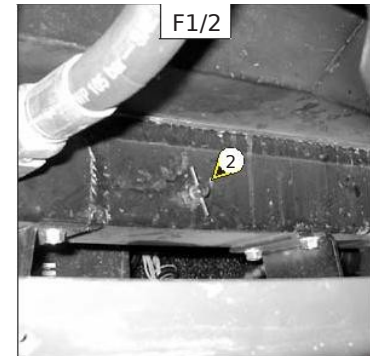
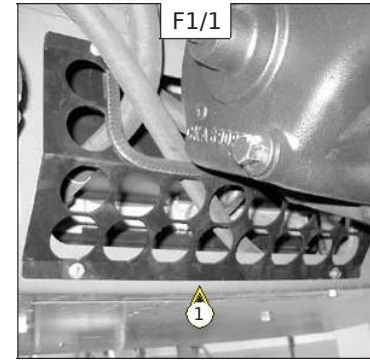

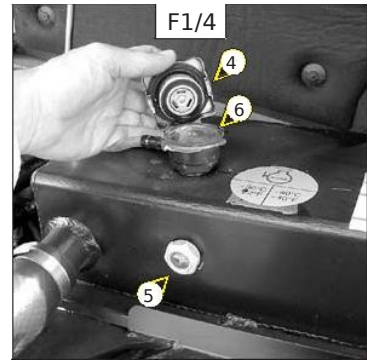

G - OCCASIONAL MAINTENANCE

G1 - FUEL SYSTEM

These operations are to be carried out only in the following cases:

- A component of the fuel system replaced.
- A drained tank.
- Running out of fuel.

Ensure that the level of fuel in the tank is sufficient and bleed in the following order:

- Open the I.C. engine bonnet.
- Put the ignition on for three minutes on the lift truck, to give the lift pump time to release air from the filter.
- Switch off the ignition with the ignition key.

BLEEDING THE INJECTORS

- Remove the injectors cover 1 (fig. G1/1).
- Loosen high pressure connectors 2 (fig. G1/2) of all the injectors.
- Activate the starter until the diesel fuel flows out free of air at high pressure connectors 2 (fig. G1/2).

Do not engage the starter motor on a continual basis for more than 30 seconds and let it cool

! *between unsuccessful attempts.*

- Tighten the connection while the diesel fuel is flowing out (tightening torque 22 ft/lb).

- The I.C. engine is then ready to be started up.
- Turn the I.C. engine over slowly for 5 minutes immediately after bleeding the fuel feed circuit, in order to ensure that the injection pump has been bled thoroughly.

NOTE: If the I.C. engine functions correctly for a short time then stops or functions irregularly, check for possible leaks in the low pressure circuit. If in doubt, contact your dealer.

BLEED

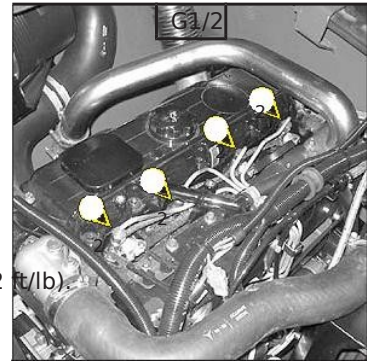
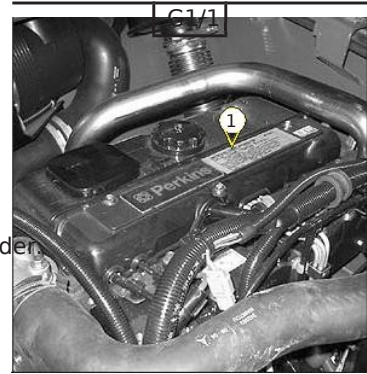

G2 - WHEEL

CHANGE

In the event of a wheel being changed on the public highway, make sure of the following points:



For this operation, we advise you to use an approved hydraulic jack and safety support.

- Stop the lift truck, if possible on even and hard ground.
- To pass on stop of lift truck (see: 1 - OPERATING AND SAFETY INSTRUCTIONS: DRIVING INSTRUCTIONS UNLADEN AND LADEN).
- Put the warning lights on.
- Immobilise the lift truck in both directions on the axle opposite to the wheel to be changed.
- Unlock the nuts of the wheel to be changed.
- Place the jack under the flared axle tube, as near as possible to the wheel and adjust the jack (fig. G2/1).
- Lift the wheel until it comes off the ground and put in place the safety support under the axle (fig. G2/2).
- Completely unscrew the wheel nuts and remove them.
- Free the wheel by reciprocating movements and roll it to the side.
- Slip the new wheel on the wheel hub.
- Refit the nuts by hand, if necessary grease them.
- Remove the safety support and lower the lift truck with the jack.
- Tighten the wheel nuts with a torque wrench (see: 3 - MAINTENANCE: A - DAILY OR EVERY 10 HOURS SERVICE for tightening torque).





Do not tow the lift truck at more than 25 km/h.

- Put the forward/reverse lever and the gear shift in neutral (as model of lift truck).
- Release the parking brake.
- Put the warning lights on.
- If the I.C. engine is not running there will be no steering or braking assistance. Operate the steering and pedal slowly avoiding sudden jerky movements.

MT 732 Série C-E2
 MT 732 Turbo Série C-E2
 MT 932 Série C-E2
 MT 932 Turbo Série C-E2

- Take into account the position of the lift truck gravity center for lifting (fig. G4/1).

A = 1480 mm	B = 1080 mm	MT 732	Série C-E2
A = 1480 mm	B = 1080 mm	MT 732	Turbo Série C-E2
A = 1465 mm	B = 1095 mm	MT 932	Série C-E2
A = 1480 mm	B = 1080 mm	MT 932	Turbo Série C-E2

- Place the hooks in the fastening points provided (fig. G4/2 and G4/3).

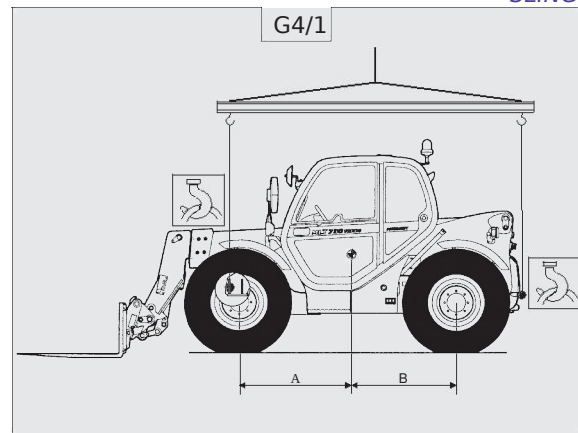

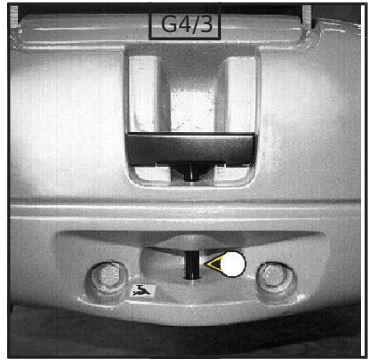
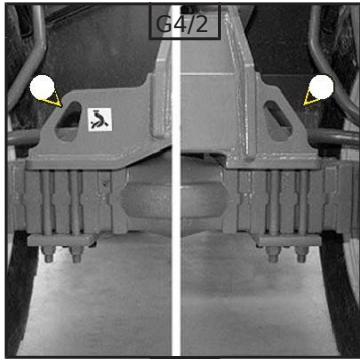



G5 - LIFT TRUCK ON A
PLATFORM

MT 732 Série C-E2
 MT 732 Turbo Série C-E2
 MT 932 Série C-E2
 MT 932 Turbo Série C-E2
 MT 1030 S Série 3-E2
 MT 1030 S Turbo Série 3-E2

 Ensure that the safety instructions connected to the platform are respected before the loading of the lift truck and that the driver of the means of transport is informed about the dimensions and the weight of the lift truck (see: 2 - DESCRIPTION: CHARACTERISTICS).

 Ensure that the platform has got dimensions and a load capacity sufficient for transporting the lift truck. Check also the pressure on the contact surface allowable for the platform in connection with the lift truck.

 For lift trucks equipped with a turbo-charged I.C. engine, block off the exhaust outlet to avoid rotation of the turbo shaft without lubrication when transporting the vehicle.

LOAD THE LIFT TRUCK

- Block the wheels of the platform.
- Fix the loading ramps so that you obtain an angle as little as possible to lift the lift truck.
- Load the lift truck parallel to the platform.
- Stop the lift truck (see: 1 - OPERATING AND SAFETY INSTRUCTIONS: DRIVING INSTRUCTIONS UNLADEN AND LADEN).

STOW THE LIFT TRUCK

- Fix the chocks to the platform at the front and at the back of each tyre (fig. G5/1).
- Fix also the chocks to the platform in the inside of each tyre (fig. G5/2).
- Stow the lift truck on the platform with enough resisting ropes. At the front of the lift truck, on the fastening points 1 (fig. G5/3) and at the back, on the towing pin 2 (fig. G5/4).
- Tighten the ropes (fig. G5/5).

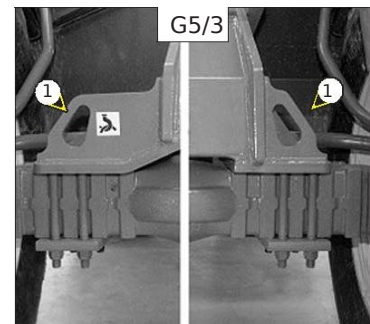
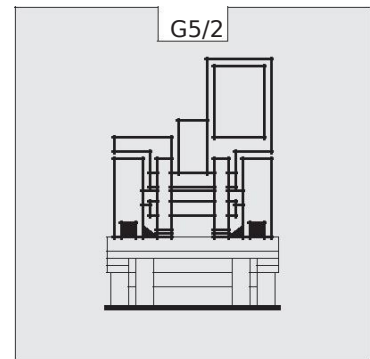
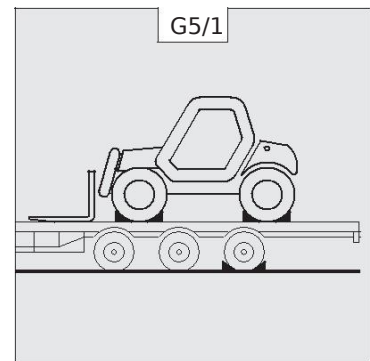

MT 732 ... / MT
932 ...

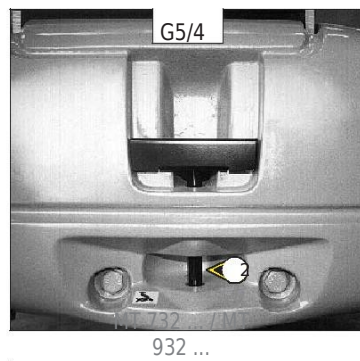
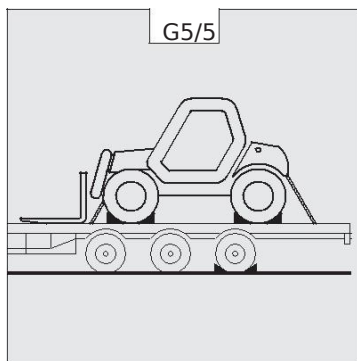

G6 - FRONT HEADLAMPS

ADJUST

RECOMMENDED SETTING

(as per standard ECE-76/756 76/761 ECE20)

Set to - 2% of the dipped beam in relation to the horizontal line of the headlamp.

ADJUSTING PROCEDURE

- Place the lift truck unloaded and in the transport position and perpendicular to a white wall on flat, level ground (fig. G6).
- Check the tyre pressures (see: 2 - DESCRIPTION: CHARACTERISTICS).
- Put the gear reverser lever in neutral and release the parking brake.

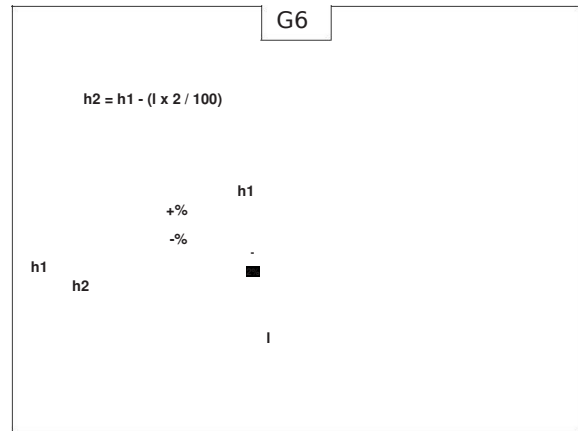

CALCULATING THE HEIGHT OF THE DIPPED BEAM (H2)

- h_1 = Height of the dipped beam in relation to the ground.
- h_2 = Height of the adjusted beam.
- l = Distance between the dipped beam and the white wall.

H - EVERY TWO YEARS (OPTION AIR CONDITIONING)

WARNING: NEVER TRY TO REPAIR ANY ANOMALIES YOURSELF. TO RECHARGE A CIRCUIT, ALWAYS CONTACT YOUR DEALER WHO HAS THE



APPROPRIATE SPARE PARTS, TECHNICAL TRAINING AND NECESSARY TOOLS.

- Do not open the circuit under any circumstances as this would cause the coolant to be lost.
- The cooling circuit contains a gas which can be dangerous under certain conditions. This gas, coolant R 134a, is colourless, odourless and heavier than air.



- *If this gas is inhaled, take the victim into fresh air, give oxygen or artificial respiration if necessary and call a doctor.*

- *If the gas is in contact with the skin, wash it immediately under running water and remove any contaminated garments.*

- *If the gas is in contact with the eyes, rinse them in clear water for 15 minutes and call a doctor.*

- The charger has an oil level gauge; never unscrew this gauge because it would depressurise the installation. The oil level is only checked when changing the oil in the circuit.



H1 - CLEANING THE CONDENSER AND EVAPORATOR COILS (*)

H2 - CLEANING THE HOTWELL AND THE PRESSURE RELIEF VALVE (*)

H3 - COLLECTING THE COOLANT TO REPLACE THE FILTER-DRIER (*)

H4 - RELOADING COOLANT AND CHECKING THE THERMOSTATIC CONTROL AND PRESSURE SWITCHES (*)

NOTE: When opening the evaporator unit, remember to replace the cover seal.

(*): (CONSULT YOUR DEALER).

*4 - PICKING UP
THE
ATTACHMENTS*

TABLE OF CONTENTS

<i>INTRODUCTION</i>	4 - 5
---------------------	-------

<i>PICKING UP THE ATTACHMENTS</i>	4 - 6
-----------------------------------	-------

A - ATTACHMENT WITHOUT HYDRAULICS AND HAND LOCKING DEVICE	4 - 6
---	-------

B - ATTACHMENT WITHOUT HYDRAULICS AND HYDRAULIC LOCKING DEVICE (OPTION)	4 - 7
---	-------

C - HYDRAULIC ATTACHMENT AND HAND LOCKING DEVICE	4 - 8
--	-------

D - HYDRAULIC ATTACHMENT AND HYDRAULIC LOCKING DEVICE (OPTION)	4 - 9
--	-------

INTRODUCTION

- Your lift truck must be used with interchangeable equipment. These items are called: ATTACHMENTS.
- A wide range of attachments, specially designed and perfectly suitable for your lift truck is available and guaranteed by MANITOU.
- The attachments are delivered with a load chart concerning your lift truck. The operator's manual and the load chart should be kept in the places provided in the lift truck. For standard attachments, their use is governed by the instructions contained on this notice.

 We would remind users that the MT 928 Série C-E2, MT 932 Série C-E2, MT 932 Turbo Série C-E2, MT 1030 S Série 3-E2, MT 1030 S Turbo Série 3-E2, are lift trucks essentially intended for handling. Occasional use with the buckets CBC 800/900 and CBR 900/1000 is authorised, but under no circumstances is intensive use for difficult applications (quarry, waste, cereals, agriculture, etc) permissible.

In addition, use of the lift truck with the buckets CBC 800/900 and CBR 900/1000 should be with the jib completely retracted, in order to reduce the constraints on the jib head.

Use of other buckets CBA, CBC, CBM, CBR, CB, CBG and manure forks FFGR is forbidden.

- Some particular uses require the adaptation of the attachment which is not provided in the price-listed options. Optional solutions exist, consult your dealer.

 Only attachments approved by MANITOU are to be used on our lift trucks (see: 4 - ADAPTABLE ATTACHMENTS IN OPTION ON THE RANGE: TECHNICAL SPECIFICATIONS OF ATTACHMENTS). The manufacturer's liability will be denied in case of modification or of attachment adaptation carried out without his knowing it.

 Depending on their size, certain attachments may, when the jib is lowered and retracted, come into contact with the front tyres and cause damage to them, if reverse tilt is activated in the forward tilt direction. TO REMOVE THIS RISK, EXTEND THE TELESCOPE TO A SUFFICIENT EXTENT FOR THE PARTICULAR LIFT TRUCK AND ATTACHMENT SO THAT THIS CONTACT IS NOT POSSIBLE.

 Maximum loads are defined by the capacity of a lift truck taking account of the attachment's mass and centre of gravity. In the event of the attachment having less capacity than the lift truck, never exceed this limit.

A - ATTACHMENT WITHOUT HYDRAULICS AND HAND LOCKING DEVICE

TAKING UP AN ATTACHMENT

- Ensure that the attachment is in a position facilitating the locking to the carriage. If it is not correctly oriented, take the necessary precautions in order to move it safely.
- Check that the locking pin and the clip are in position in the bracket (fig. A).
- Place the lift truck with the jib lowered in front of and parallel to the attachment, tilt the carriage forwards (fig. B).
- Bring the carriage under the locking tube of the attachment, slightly lift the jib, incline the carriage backwards in order to position the attachment (fig. C).
- Lift the attachment off the ground to facilitate locking.

HAND LOCKING

- Take the locking pin and the clip on the bracket (fig. A) and lock the attachment (fig. D). Do not forget to refit the clip.

HAND RELEASING

- Proceed in the reverse order of paragraph HAND LOCKING while making sure you put back the locking pin and the clip in the bracket (fig. A).

LAYING AN ATTACHMENT

- Proceed in the reverse order of paragraph TAKING UP AN ATTACHMENT while making sure you place the attachment flat on the ground and in closed position.

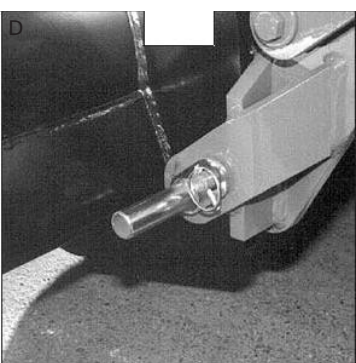
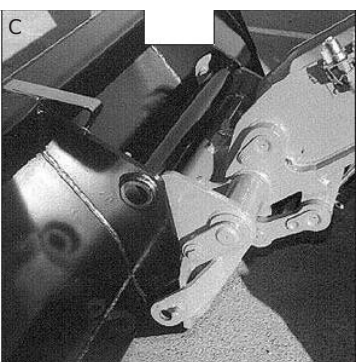
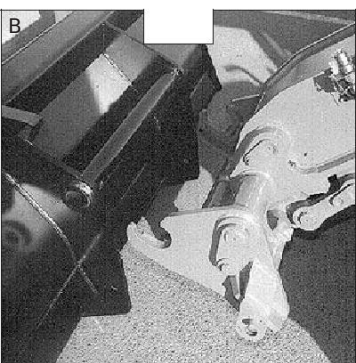

B - ATTACHMENT WITHOUT HYDRAULICS AND HYDRAULIC LOCKING DEVICE (OPTION)

4 - 7

MT 732 Série C-E2
MT 732 Turbo Série C-E2
MT 932 Série C-E2
MT 932 Turbo Série C-E2

TAKING UP AN ATTACHMENT

- Ensure that the attachment is in a position facilitating the locking to the carriage. If it is not correctly oriented, take the necessary precautions in order to move it safely.
- Check that the rods on the locking cylinder are retracted (fig. A).
- Place the lift truck with the jib lowered in front of and parallel to the attachment, tilt the carriage forwards (fig. B).
- Bring the carriage under the locking tube of the attachment, slightly lift the jib, incline the carriage backwards in order to position the attachment (fig. C).
- Lift the attachment off the ground to facilitate locking.

HYDRAULIC LOCKING

- Put the valve in position A (fig. D), that is to say, the hydraulic circuit of the attachment locking open.
- Lift up and push the lever of the distributor 1 (fig. E) to the right in order to completely lock the attachment on the carriage.
- Close the valve in position B (fig. D), that is to say, the hydraulic circuit of the attachment locking closed.

 *Always close the valve in position B (fig. D) after the locking of the attachment, in order to avoid accidental unlocking and use the attachment safety.*

HYDRAULIC RELEASING

- Put the valve in position A (fig. D), that is to say, the hydraulic circuit of the attachment locking open.
- Lift up and push the lever of the distributor 1 (fig. E) to the left in order to unlock the attachment.

LAYING AN ATTACHMENT

- Proceed in the reverse order of paragraph TAKING UP AN ATTACHMENT while making sure you place the attachment flat on the ground and in closed position.

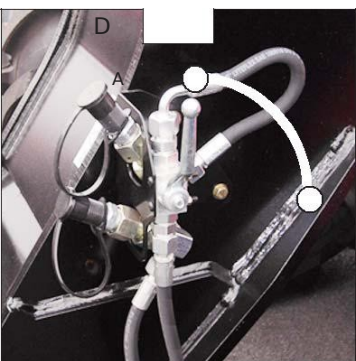
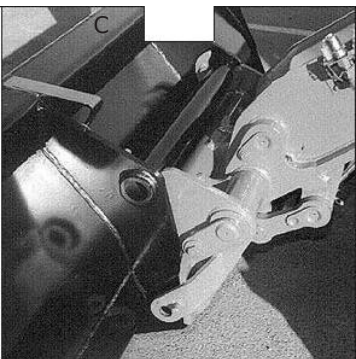
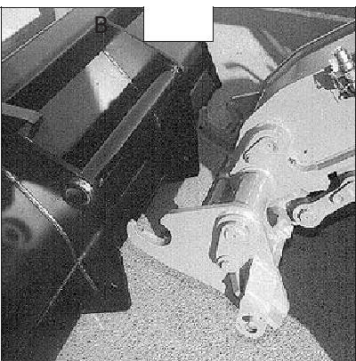
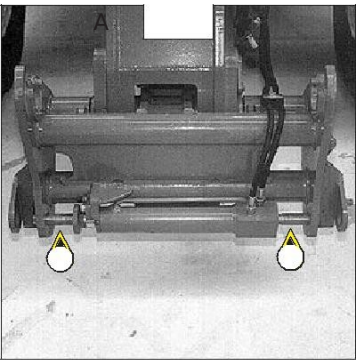

MT 732 ... / MT 932 ...

C -
HYDR
AULI
C
ATTA
CHM
ENT
AND
HAN
D
LOCK
ING
DEVI
CE

STANDARD MT

MT 732

MT 932

MT 932

p
o
-P
l
-B
r
-L
i
H
A
-T
a
-S
t
-R
e
-C
o
-P
r
L
A
-P
r



a

H

A

TAKING
UP AN
ATTACH
MENT

- Ensure that the attachment is in a position facilitating the locking to the carriage. If it is not correctly oriented, take the necessary precautions in order to move it safely.
- Check that the locking pin and the clip are in

B

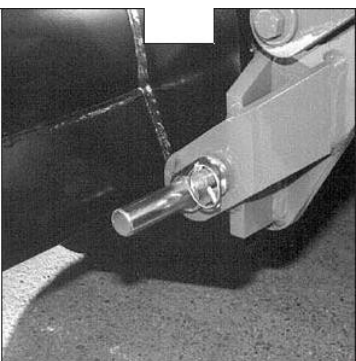
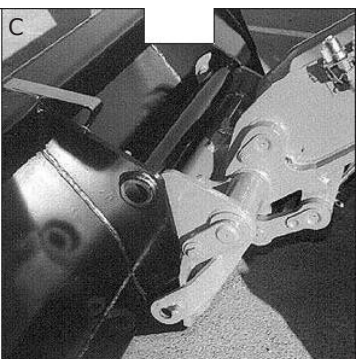
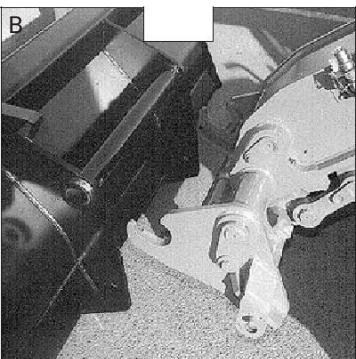

D



E

D - HYDRAULIC ATTACHMENT AND HYDRAULIC LOCKING DEVICE (OPTION)

MT 732 Série C-E2
MT 732 Turbo Série C-E2
MT 932 Série C-E2
MT 932 Turbo Série C-E2

TAKING UP AN ATTACHMENT

- Ensure that the attachment is in a position facilitating the locking to the carriage. If it is not correctly oriented, take the necessary precautions in order to move it safely.
- Check that the rods on the locking cylinder are retracted (fig. A).
- Place the lift truck with the jib lowered in front of and parallel to the attachment, tilt the carriage forwards (fig. B).
- Bring the carriage under the locking tube of the attachment, slightly lift the jib, incline the carriage backwards in order to position the attachment (fig. C).
- Lift the attachment off the ground to facilitate locking.

HYDRAULIC LOCKING AND CONNECTING THE ATTACHMENT

- Put the valve in position A (fig. D), that is to say, the hydraulic circuit of the attachment locking open.
- Lift up and push the lever of the distributor 1 (fig. E) to the right in order to completely lock the attachment on the carriage.
- Stop the I.C. engine.
- Remove the pressure of the attachment hydraulic circuit by using the lever of the distributor 1 (fig. E).
- Connect the rapid connectors according to the logic of the attachment's hydraulic movements.

 *Make sure that the rapid connectors are clean and protect the holes which are not used, with the caps provided.*

- Close the valve in position B (fig. D), that is to say, the hydraulic circuit of the attachment locking closed.

 *Always close the valve in position B (fig. D) after the locking of the attachment, in order to avoid accidental unlocking and use the attachment safely.*

HYDRAULIC RELEASING AND DISCONNECTING THE ATTACHMENT

- Close the attachment.
- Put the valve in position A (fig. D), that is to say, the hydraulic circuit of the attachment locking open.
- Lift up and push the lever of the distributor 1 (fig. E) to the left in order to unlock the attachment.
- Stop the I.C. engine.
- Remove the pressure of the attachment hydraulic circuit by using the lever of the distributor 1 (fig. E).
- Disconnect the rapid connectors of the attachment.

 *Make sure that the rapid connectors are clean and protect the holes which are not used, with the caps provided.*

LAYING AN ATTACHMENT

- Proceed in the reverse order of paragraph TAKING UP AN ATTACHMENT while making sure you place the attachment flat on the ground and in closed position.



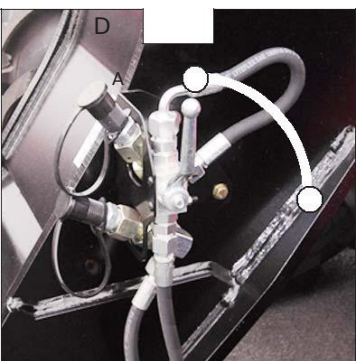
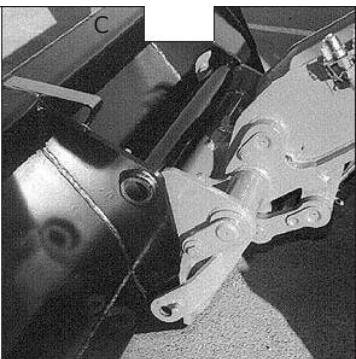
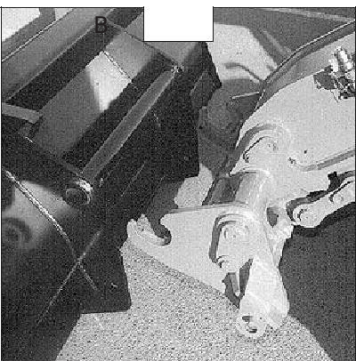
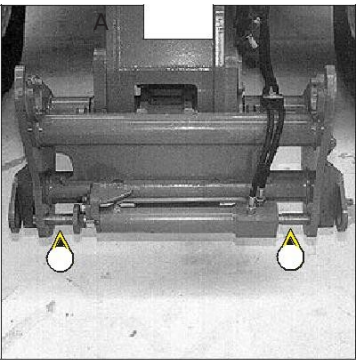

E

B

1

