

**OPERATION AND MAINTENANCE**

**OMBC2019DSMENG.607**

**CUTTER-CRUSHER**  
**SANDVIK BC 2019 D-JAW**  
**SANDVIK BC 2019 S-JAW**  
**SANDVIK BC 2019 M-JAW**

<b>OPERATION</b> .....	<b>3</b>	Installation of cutting blades. ....	55
1. Foreword .....	4	3. Turning and changing cutting	
Preface .....	4	blades .....	56
This manual .....	4	Wear limits, adjustments and	
Important safety information .....	5	torques for cutting blades .....	56
Warranty. ....	6	Removal of cutting blades .....	57
Spare part orders. ....	6	Installation of cutting blades. ....	58
2. Machine numbers .....	7	4. Turning and changing cutting	
Model and serial number .....	7	blades .....	59
3. Product introduction. ....	8	Wear limits, adjustments and	
Overview. ....	8	torques for cutting blades .....	59
Removal from package .....	8	Removal of cutting blades .....	60
Lifting instructions .....	8	Installation of cutting blades. ....	61
Main parts .....	12	5. Replacing crusher teeth .....	62
Environmental protection and		Tightening torque for	
recycling policy .....	12	crusher tooth .....	62
4. Safety .....	14	Removal of crusher tooth .....	62
General safety .....	14	Installation of crusher tooth .....	62
Safety instructions. ....	14	6. Replacing wood cutting teeth .....	64
5. Optional equipment .....	20	Tightening torque for wood	
Water jet .....	20	cutting tooth. ....	64
Changing the jaws on site .....	21	Removal of wood cutting tooth .....	64
6. Operation .....	25	Installation of wood cutting tooth ....	64
Operating instructions. ....	25	7. Replacing crushing plate. ....	66
Daily operation .....	27	Tightening torque for	
Mounting and dismounting the		pulverizing plate .....	66
equipment .....	35	Removal of pulverizing plate .....	66
Movement. ....	36	Installation of pulverizing plate .....	67
Special conditions of use .....	37	8. Replacing jaws guide plates .....	68
Storage .....	37	Wear limits for guide plates .....	68
<b>LUBRICATION</b> .....	<b>39</b>	Welding tools .....	68
1. Greasing .....	40	Removal of guide plates .....	69
Recommended greases. ....	40	Installation of guide plates .....	69
Greasing points .....	40	9. Troubleshooting. ....	70
2. Carrier hydraulic oil .....	43	Machine does not crush .....	70
Requirements for hydraulic oil .....	43	Machine does not cut .....	70
Oil cooler .....	45	Crusher jaw does not move .....	70
Oil filter .....	46	Excessive moving .....	71
<b>MAINTENANCE</b> .....	<b>49</b>	Oil leakage .....	71
1. Routine maintenance .....	50	High speed valve problems .....	71
Overview. ....	50	Further assistance .....	72
Inspection and maintenance by the		<b>SPECIFICATIONS</b> .....	<b>73</b>
operator .....	50	1. Product specifications. ....	74
Inspection and maintenance by the		Technical specifications .....	74
dealer .....	51	Main dimensions D-JAW .....	75
Maintenance intervals in special		Main dimensions S-JAW. ....	76
applications. ....	52	Main dimensions M-JAW. ....	77
Other maintenance procedures .....	52		
2. Turning and changing cutting			
blades. ....	53		
Wear limits, adjustments and			
torques for cutting blades .....	53		
Removal of cutting blades. ....	54		

---

# OPERATION

---

# I. FOREWORD

---

## I.1 PREFACE

---

Congratulations on having purchased this product. A properly installed attachment should prove to be a productive machine requiring maintenance at only regular intervals.

## I.2 THIS MANUAL

---

This manual is arranged to give you a good understanding of the equipment and its safe operation. It also contains maintenance information and technical specifications. Read this manual from front to back before installing, operating or maintaining the attachment for the first time.

In this manual, the units of measurement are metric. For example, weights are given in kilograms (kg). In some cases the other unit follows in parenthesis (.). For example 28 litres (7.4 US gal).

The specifications and designs presented in this manual are subject to change without prior notice.

### **SYMBOLS USED IN THIS MANUAL**

This symbol identifies important safety messages within this manual. Carefully read the message that follows. Failure to understand and obey this safety warning could result in injury to you or others, and could also cause damage to equipment. See illustration 1.

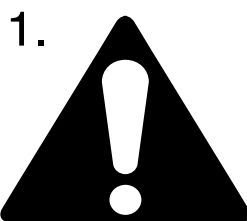

R010127

This symbol identifies prohibited action or hazardous location. Failure to understand and obey this safety warning could result in injury to you or others, and could also cause damage to equipment. See illustration 2.

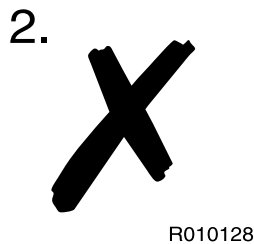

This symbol identifies correct and recommended action. See illustration 3.

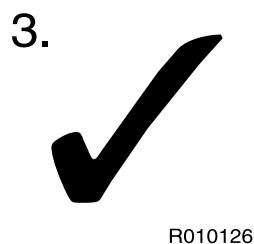

This symbol identifies environmental and recycling matter. See illustration 4.

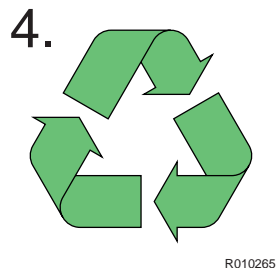

### **I.3 IMPORTANT SAFETY INFORMATION**

---

Basic safety precautions are outlined in the "Safety" section of this manual and in the description of operations where hazards exist. These warnings are identified by the warning symbol.

To use the attachment correctly, you must also be a competent operator of the carrier machine. Do not use or install it if you can not use the carrier machine. The attachment is a powerful tool. Used without proper care, it can cause damage.

Do not rush when you are learning to use the product. Take your time and most importantly, take it safely. Do not guess. If there is anything you do not understand, ask your local dealer. He will be pleased to advise you.

Improper operation, lubrication or maintenance of this machine can be dangerous and could result in injury.

Do not operate this machine until you read and understand the instructions in this manual.

Do not perform any lubrication and maintenance on this machine until you read and understand the instructions in this manual.

## **I.4 WARRANTY**

---

The customer is provided with a separate warranty sheet, where the export warranty terms are explained. Check always that this warranty sheet is provided with the attachment. If not, contact your local dealer immediately.

### **WARRANTY REGISTRATION CARD**

A warranty registration card is filled out after the installation inspection by the dealer and a copy of it is sent to the manufacturer. This card is very important because no warranty claims are handled without it. Make sure that you get a copy of it after the installation inspection and that it is correctly filled out.

### **INSTALLATION INSPECTION**

An installation inspection must be carried out after the product has been installed on the carrier. In the installation inspection certain specifications (operating pressure, oil flow, etc.) are checked so that they are within given limits. See “Product specifications” on page 74.

## **I.5 SPARE PART ORDERS**

---

When you need spare parts or some information concerning maintenance to your machinery, please contact your local dealer. Quick deliveries are ensured by exact orders.

Required information:

1. Name of customer, contact person
2. Order number (when available)
3. Delivery address
4. Mode of delivery (air mail, etc.)
5. Required delivery date
6. Invoicing address
7. Model and serial number of product
8. Name, number and required amount of spare parts

## 2. MACHINE NUMBERS

### 2.1 MODEL AND SERIAL NUMBER

The equipment serial number is stamped on the equipment body. The model and serial number are also located on the CE marking. Check that the model corresponds to the one given on the cover of this manual.

It is important to make correct reference to the serial number of the attachment when making repairs or ordering spare parts. Identification of the serial number is the only proper means of maintaining and identifying parts for a specific product.

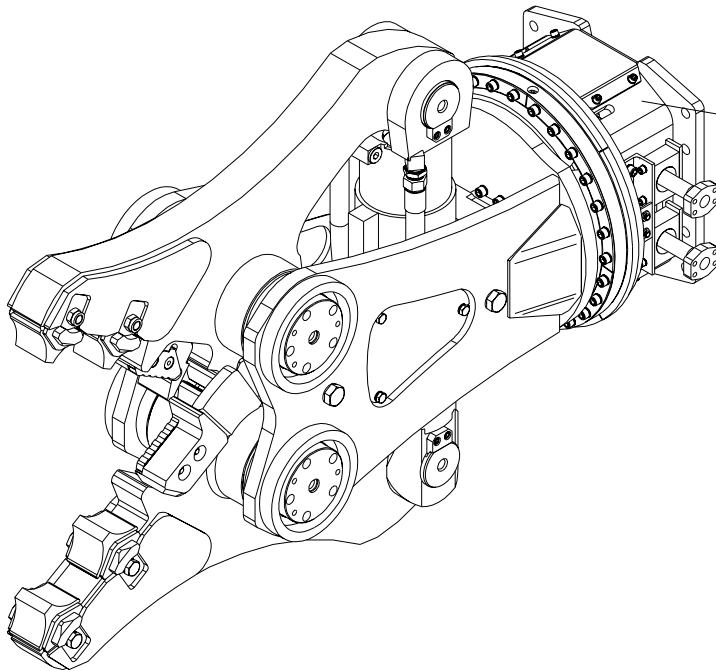

<b>CE</b>	
MANUFACTURING DATE .....	.....
S/N .....	.....
MODEL .....	.....
.....	kg
<i>Cylinder</i>	.....
.....	l/min
.....	MPa
<i>Rotation</i>	.....
.....	l/min
.....	MPa
SANDVIK MINING AND CONSTRUCTION OY,  BREAKERS LAHTI, FINLAND	

M010080

## 3. PRODUCT INTRODUCTION

---

### 3.1 OVERVIEW

---

The product is a hydraulically operated crusher. It can be used on any carrier which meets the necessary hydraulic and mechanical installation requirements.

### 3.2 REMOVAL FROM PACKAGE

---

Remove all the steel belts from the package. Open the package and remove all plastics covering the product. Recycle all package materials (steel, plastic, wood) properly.

Check that the product is in good condition and that there is no visible damage. Check that all ordered parts and accessories have been enclosed with the product. Some options may be provided by your local dealer like installation kits; including hoses and mounting bracket.

### 3.3 LIFTING INSTRUCTIONS

---

Use a hoist when lifting components which weigh 23 kg or more, to avoid back injury. Make sure all chains, hooks, slings, etc., are in good condition and are in the correct capacity. Be sure hooks are positioned correctly. Lifting eyes are not to be side loaded during a lifting operation.

#### PROVIDED LIFTING POINTS

The lifting eyes located on the Product housing are to be used solely to lift or handle the Product itself. The lifting capacity calculation is based on Product's working weight including average sized mounting bracket.



**Warning!** To avoid falling objects, do not use Product to lift other products. The lifting eyes located on the Product housing are to be used solely to lift or handle the Product itself.

The maximum allowed total weight is shown on the Product's CE-plate and specification page. See "Product specifications" on page 74. If the weight exceeds the maximum allowed total weight shown on the CE-plate and specification page, you have to use other lifting points/methods than originally provided on the Product.



The other treaded holes on the Product are intended for handling single parts only. It is forbidden to lift the entire assembly by using these threaded holes. For handling the parts, see product workshop documentation for suitable lifting methods and lifting adapters.

### LIFTING EYE SCREWS

Lifting eye screws shall be completely tightened. The lifting eye must be loaded only if the screw is properly tightened to the housing.



**Failure to properly tighten the screw before allowing load pressure on the lifting eye may cause lifting eye to break and free fall of the Product.**

If you use mechanical tools for tightening, make sure not to overstrain the shank. Before lifting make sure that the rope and/or hook is stretched.

When two lifting eye screws are used, the lifting capacity depends on the angle of the lifting chains. The angle should not be less than 45°, as shown in the illustration. When the lifting eye screws are tightened, both rings should be aligned.

The loading capacity calculation applies to temperatures between -10 °C and 40 °C.

Before reuse of lifting eye screws make sure there are no surface flaws (for example pits, voids, folds and seams, deformation of the ring, missing or broken threads, rust, etc.).

The local, national safety standards for machines and lifting-tackles must always be strictly observed.

Note: The lifting eye must always be removed from the crusher and replaced with a blanking screw before starting to operate the crusher.

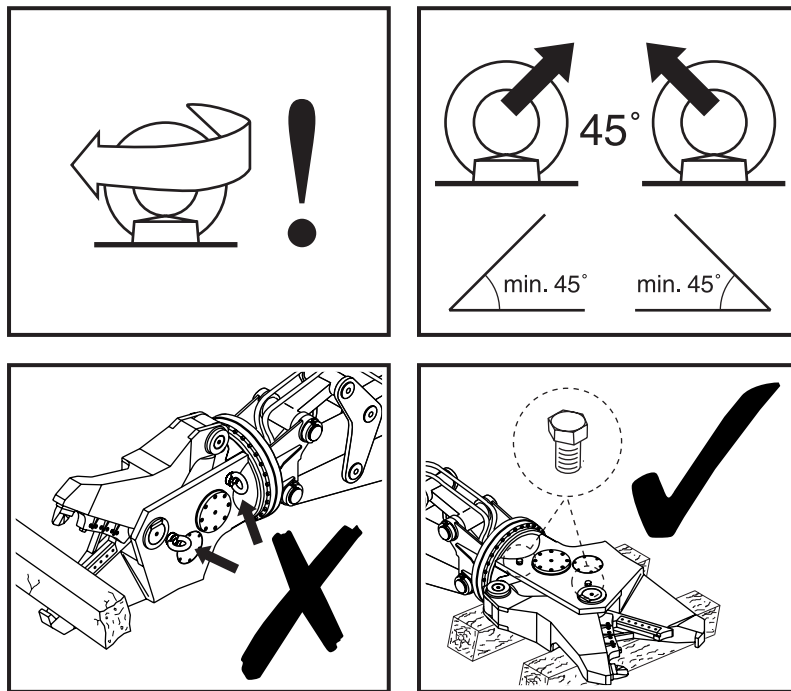

R010270

Lifting devices must safely carry the working weight of the product. See “Product specifications” on page 74. Place chains or slings, as shown by the illustration, to lift the product.

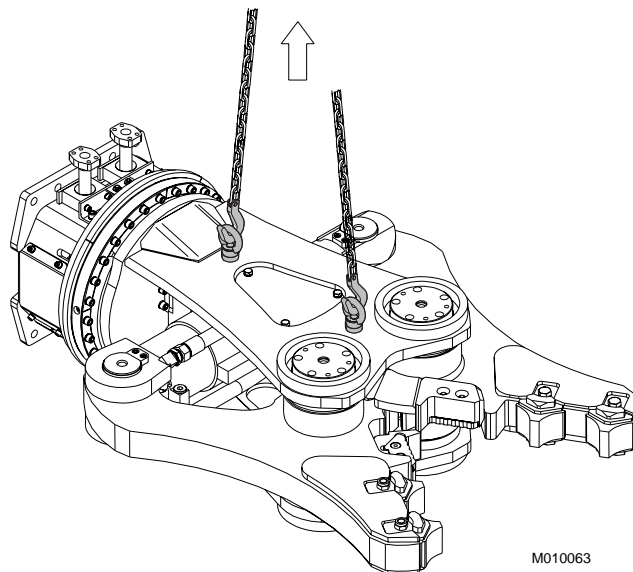

M010063

Note: The lifting eyes must always be removed from the crusher and replaced with blanking screws before starting to operate the crusher.

**SAFETY INSTRUCTIONS FOR LIFTING**

Below are some common safety instructions concerning lifting operations. In addition to this, the local, national standards for machines and lifting-tackles must always be strictly observed. Please note that the list below is not all inclusive, you must always ensure the procedure you choose is safe for you and others.

- Do not lift load over people. No one shall be under the hoisted load.
- Do not lift people and never ride the hoisted load.
- Keep people clear from lift area.
- Avoid side pull of the load. Make sure you take up the slack slowly. Start and stop carefully.
- Lift load a few centimeters and verify it before proceeding. Make sure the load is well balanced. Check for any loose items.
- Never leave the suspended load unattended. Maintain load control at all times.
- Never lift the load over the rated capacity (see product's operating weight from specification page).
- Inspect all lifting equipment before use. Do not use twisted or damaged lifting equipment. Protect lifting equipment from sharp corners.
- Obey all local safety instructions.

### 3.4 MAIN PARTS

The main parts of the cutter-crusher are shown below.

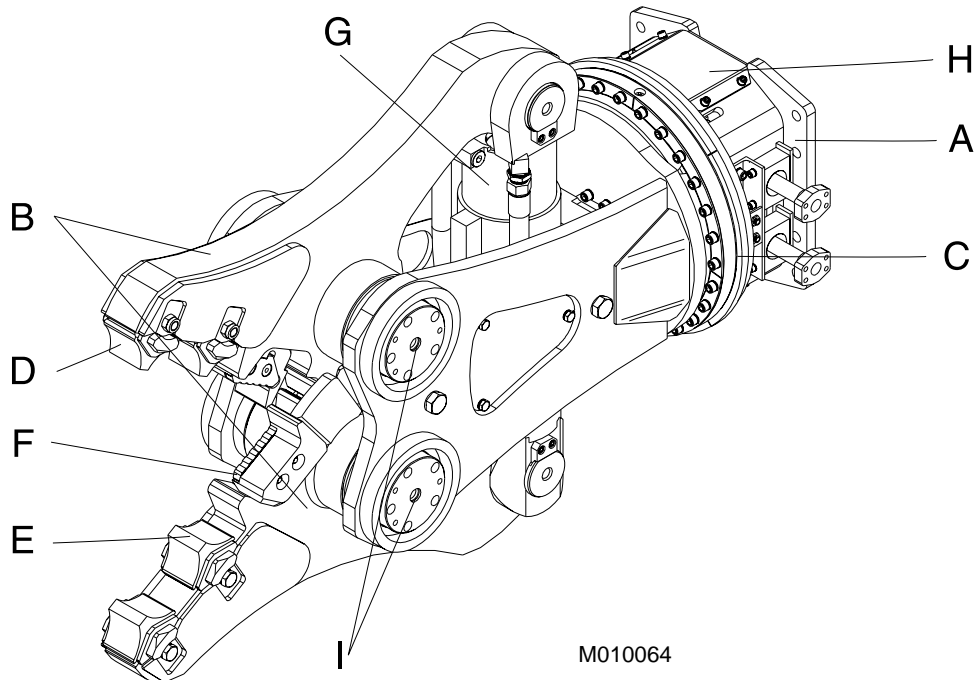

- A. Mounting bracket
- B. Jaw
- C. Slew bearing
- D. Front tooth
- E. Back tooth
- F. Cutting blade
- G. Cylinder
- H. Brake/Hydraulic motor
- I. Main shaft

### 3.5 ENVIRONMENTAL PROTECTION AND RECYCLING POLICY

Sandvik manufactures products which contribute to the recycling of materials to help customers achieve their environmental objectives. During the manufacturing all the necessary precautions are taken to make sure that no harm is done to the environment.

Sandvik strives to foresee and minimize the risks that might be caused by operation or maintenance of products, which could expose humans or the environment to danger. Sandvik support customers in their efforts to consider the environmental protection in their everyday work.

When working with Sandvik product please follow these guidelines:

- Dispose of packaging materials properly. Wood and plastic can be burned or recycled. Deliver the steel belts to metal recycling center.

- Protect environment from oil spills.

In case of hydraulic oil leaks, the equipment should be serviced immediately.

Follow the product's greasing instructions and avoid excessive greasing.

Be careful when handling, storing and transporting oils.

Dispose of empty oil or grease containers appropriately.

Consult local authorities for detailed instructions.

- All metal parts of the product can be recycled by delivering them to an authorized scrap metal collection facility.
- Comply with local waste classification rules when disposing of used rubber or plastic parts (buffers, wear plates, seals).
- When scrapping the whole product or pressure accumulator, consult your local Sandvik dealer for instructions on depressurizing the accumulator.
- Do not bring the product or accumulator to a scrap metal collection center before depressurizing the accumulator first.

Consult with your local dealer for more information.

## 4. SAFETY

---

### 4.1 GENERAL SAFETY

---

All mechanical equipment can be hazardous if operated without due care or correct maintenance. Most accidents involving machine operation and maintenance are caused by failure to observe basic safety rules or precautions. An accident can often be avoided by recognizing potentially hazardous situations before an accident occurs.

Because it is impossible to anticipate every possible circumstance that might involve a potential hazard, the warnings in this guide and on the machine are not all inclusive. If a procedure, tool, working method or operating technique not specifically recommended by manufacturer is used, you must satisfy yourself that it is safe for you and others. You should also ensure that the product will not be damaged or made unsafe by the method of operation or maintenance procedures you choose.

Safety is not just a matter of responding to the warnings. All the time you are working with your attachment you must pay attention to what hazards there might be and how to avoid them. Do not work with the product until you are sure that you control it. Do not start any job until you are sure that you and those around you will be safe.



**Warning!** Read the following warning messages carefully. They tell you of different hazards and how to avoid them. If proper precautions are not taken you or others could be seriously injured.

### 4.2 SAFETY INSTRUCTIONS

---

#### MANUALS

Study this manual before installing, operating or maintaining the product. If there is anything you don't understand, ask your employer or your local dealer to explain it. Keep this manual clean and in good condition.

Study also the operating and maintenance manual of your carrier before operating the attachment.

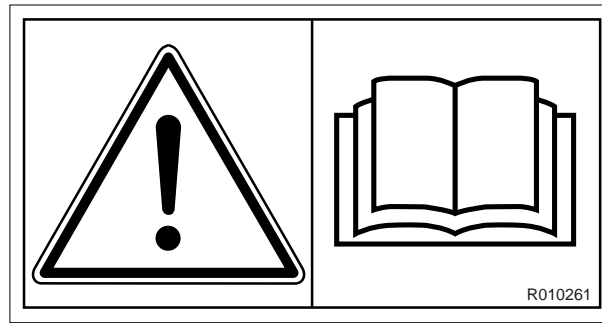

### **CARE AND ALERTNESS**

All the time you are working with the product, take care and stay alert. Always be careful. Always be alert for hazards. The possibility of a serious or even fatal accident is increased when you are intoxicated.

### **CLOTHING**

You can be injured if you do not wear proper clothing. Loose clothing can get caught in the machinery. Wear protective clothing to suit the job.

Examples are: a safety helmet, safety shoes, safety glasses, well-fitting overalls, ear-protectors and industrial gloves. Keep cuffs fastened. Do not wear a necktie or scarf. Keep long hair restrained.

### **PRACTICE**

You and others can be killed or injured if you do unfamiliar operations without practising them first. Practice away from the job site, in a clear area.

Keep other people away. Do not perform new operations until you are sure you can do them safely.

### **REGULATIONS AND LAWS**

Obey all laws, work site and local regulations which affect you and your equipment.

### **COMMUNICATIONS**

Bad communications can cause accidents. Keep people around you informed of what you will be doing. If you will be working with other people make sure they understand any hand signals you will be using.

Work sites can be noisy. Do not rely on spoken commands.

## WORK SITE

Work sites can be hazardous. Inspect the site before working on it.

Check for potholes, weak ground, hidden rocks, etc. Check for utilities (electric cables, gas and water pipes, etc.). Mark the positions of cables and pipes.

Poor visibility can cause accidents and damage. Make sure that visibility and lightning of the working area are adequate.

Work sites can be noisy. Wear ear protection to prevent personal injury.



## BANKS AND TRENCHES

Banked material and trenches can collapse. Do not work too close to banks and trenches where there is a danger of collapse.

## SAFETY BARRIERS

Unguarded equipment in public places can be dangerous. Place barriers around the machine to keep people away.

## FLYING DEMOLITION DEBRIS

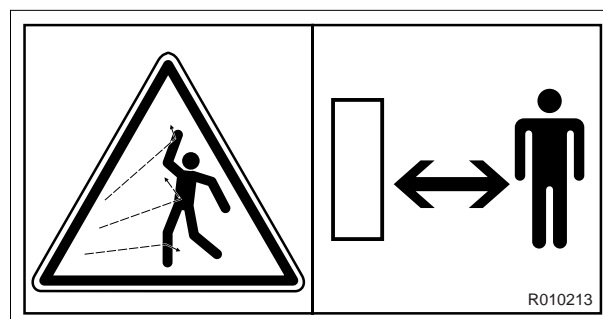

Protect yourself and your surroundings from flying debris. Do not operate the product or carrier with people around it.



The European standard EN 474-1 on safety of earth-moving machinery requires that adequate operator's protection, such as bullet proof glass, mesh guard or an equivalent protection is used.

Keep the cabin windows and doors closed during operation. Window bars are recommended to protect the windows from flying debris.

### **COLLAPSING CONCRETE FRAMES**

Protect yourself and your surroundings from collapsing concrete frames. Do not operate the product or carrier with people around it.

### **EQUIPMENT LIMITS**

Operating the product beyond its design limits can cause damage. It can also be dangerous. See "Product specifications" on page 74.

Do not try to upgrade the product's performance by unapproved modifications.

### **HYDRAULIC FLUID**

Fine jets of hydraulic fluid at high pressure can penetrate the skin. Do not use your fingers to check for hydraulic fluid leaks. Do not put your face close to suspected leaks. Hold a piece of cardboard close to suspected leaks and then inspect the cardboard for signs of hydraulic fluid. If hydraulic fluid penetrates your skin seek medical help immediately.

Hot hydraulic fluid can cause severe injuries.

### **HYDRAULIC HOSES AND FITTINGS**

Ensure all hydraulic components will withstand maximum pressure and mechanical stresses caused by operation of the attachment. Consult your local dealer for instructions.

### **FIRE HAZARD**

Most hydraulic fluids are flammable and might ignite when contacting hot surface. Avoid spilling hydraulic fluid to hot surfaces.

Working with the product on certain materials can cause sparks and hot splinters to get loose. These can ignite flammable materials around working area.

Ensure that adequate extinguisher is available.

## **HYDRAULIC PRESSURE**

Hydraulic fluid at system pressure can injure you. Before disconnecting or connecting hydraulic hoses, stop the carrier engine, operate the controls to release pressure trapped in the hoses. During the operation, keep people away from the hydraulic hoses.

There might be pressurized oil trapped inside the product even if it is disconnected from the carrier. Be aware of possible unexpected jaw movements while greasing or removing and installing cutting blades.

## **LIFTING EQUIPMENT**

You can be injured if you use faulty lifting equipment. Make sure that lifting equipment is in good condition. Make sure that the lifting tackle complies with all local regulations and is suitable for the job. Make sure that the lifting equipment is strong enough for the job and you know how to use it.

Do not use this product or any of its parts for lifting. See “Lifting instructions” on page 8. Contact your carrier dealer to find out how to lift with your carrier.

## **SPARE PARTS**

Use only genuine spare parts. Use only genuine cutting blades with crushers. The use of other spare part or cutting blade brands may damage the product.

## **EQUIPMENT CONDITION**

Defective equipment can injure you or others. Do not operate equipment which is defective or has missing parts.

Make sure the maintenance procedures in this manual are completed before using the product.

## **REPAIRS AND MAINTENANCE**

Do not try to do repairs or any other maintenance work you do not understand.

## **MODIFICATIONS AND WELDING**

Non-approved modifications can cause injury and damage. Contact your local dealer for advice before modifying the product. Before welding on the product while it is installed on the carrier, consult your carrier dealer for precautions in welding.

**METAL SPLINTERS**

You can be injured by flying splinters when driving metal pins in and out. Use soft-faced hammer or drifts to remove and fit metal pins, such as pivot pins. Always wear safety glasses.

## 5. OPTIONAL EQUIPMENT

### 5.1 WATER JET

Crushers could be equipped with an integrated water spray system. The water supply is connected to the crusher by using JIC 06 (9/16-18) connector in hose support in the mounting bracket. The internal hoses lead to the circle of the mounting bracket and the water is sprayed through the nozzles onto the object to be broken.

The principle behind the water spray system is to decrease the amount of dust caused by the breaking operation. The water jet reduces the amount of dust effectively. The use of this system is especially recommended for demolition applications.

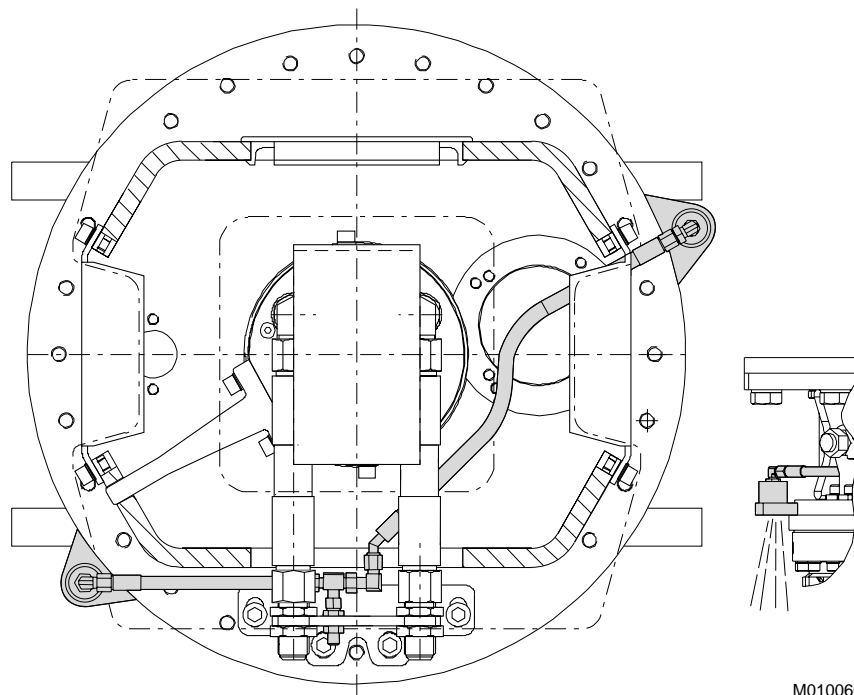

In closed spaces like tunnels and buildings, the operation of a crusher may create excessive dust and therefore makes the operation of both carrier and crusher more difficult and thus reduce productivity.

## 5.2 CHANGING THE JAWS ON SITE

### PLACING THE ASSEMBLING STANDS

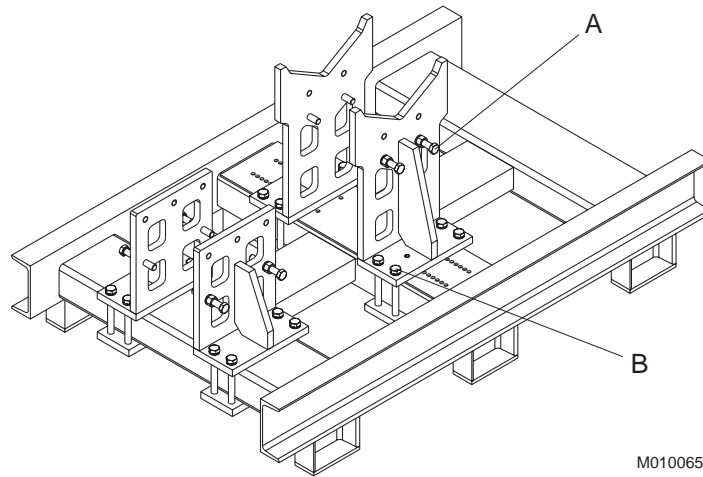

M010065

Item	Purpose
Tightening screws (A), 8 pcs	Fasten the jaw to the assembling stand for storage or transportation.
Tightening screws (B), 16 pcs	Fasten the assembling stand supports.



**Warning!** Place the assembling stands only on flat surface to prevent them from moving and falling over.

Note: The jaws must be secured to the assembling stand to prevent them from moving and falling off.

1. Place the assembling stands as shown in the illustration.

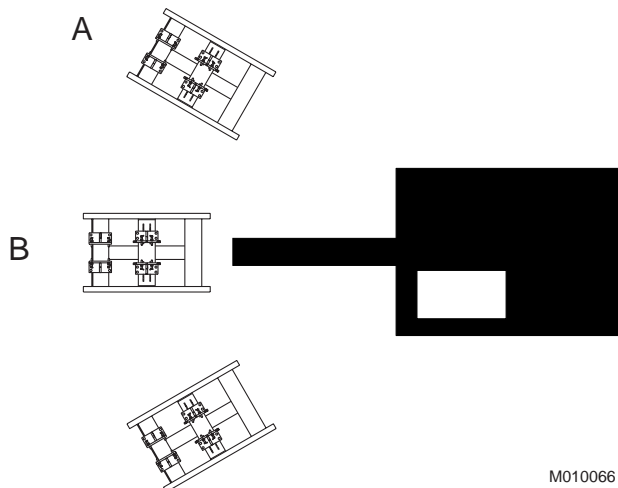

M010066

2. Loose the tightening screws so that the supports move freely.
3. Measure the width of BC 807, BC 1515, BC 2019, BC 2525, BC 3032 and RD cutter-crusher jaw and adjust the width of assembling stand supports accordingly (+5...+10 mm). Notice the teeth, weldings, etc. when measuring the width.

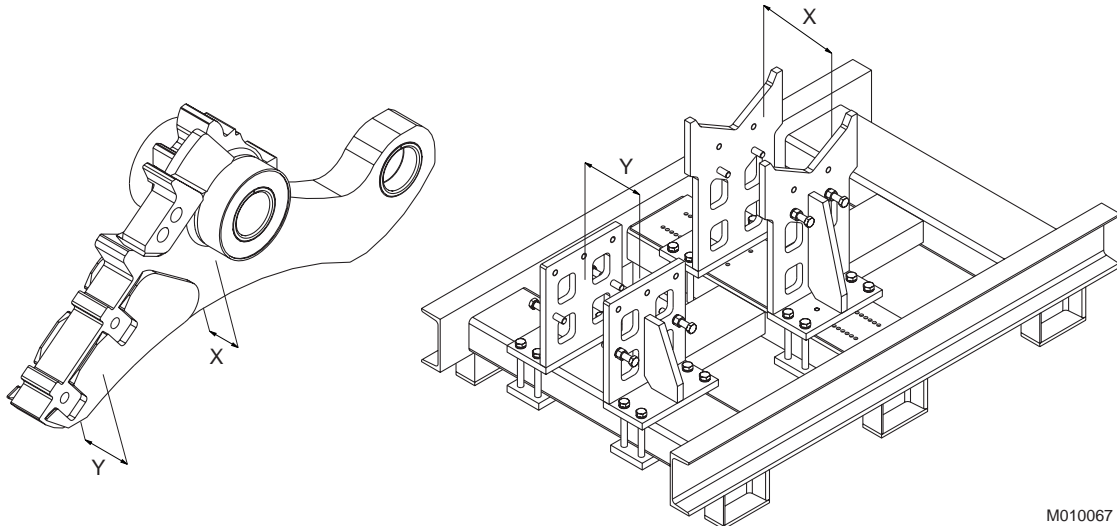

M010067

4. Tighten the tightening screws and make sure that the supports can not move.

## CHANGING THE JAWS



**Warning!** Obey all safety instructions mentioned in the operation and maintenance manual.

**Warning!** Only professionally skilled mechanics are allowed to change the jaws. Do not try to change the jaws without knowledge.

**Warning!** Keep other people away when changing the jaws.

**Warning!** The cutter-crusher and jaws must be secured from falling down in either direction when handling it.

**Note:** When changing steel jaws the lighter jaw must always be installed first and removed last. In other words there should not be a situation when only the heavier steel jaw is installed. This is for better stability to keep jaw open.

**Note:** When changing the jaws always fasten it to the cylinder first.

**Note:** Even if the cutter-crusher is mounted on the excavator and should not drop down unexpectedly, do not rely only on the hydraulics to keep the cutter-crusher from dropping down. **Obey extreme caution when changing the jaws!**

Note: Both jaws of pair have specific tothing which means each pair of jaws has A and B jaw. Do not install two A jaws or two B jaws at the same time.

1. Place the cutter-crusher on the first free assembling stand.

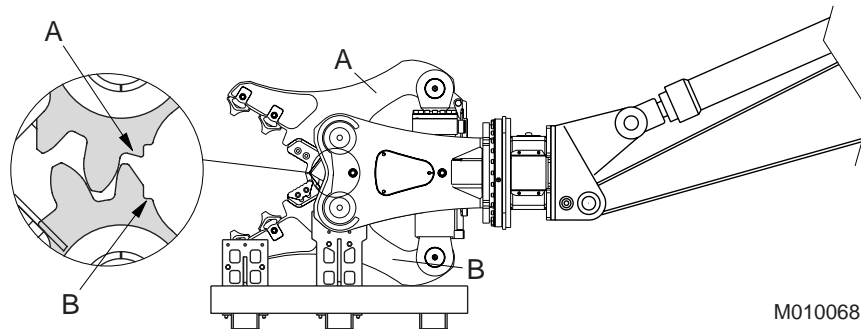

M010068

2. Remove the lower jaw and lift the cutter-crusher up. The cylinder weight will force the upper jaw against the stopper (maximum opening).

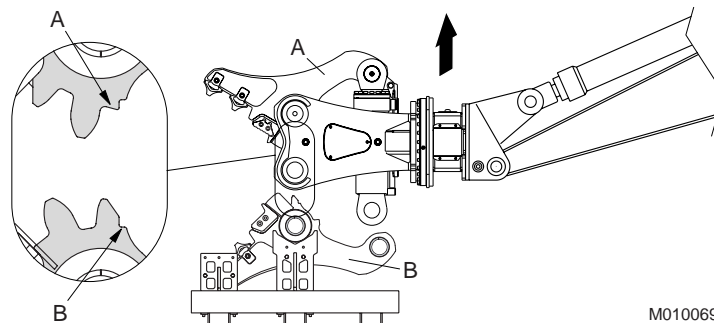

M010069

Note! Use lifting straps to prevent the cutter-crusher from rotating. Do not rely on the hydraulics!

Note! Be very careful when lifting the cutter-crusher. Do not tilt the cutter-crusher when lifting.

3. Lower the cutter-crusher on the second assembling stand and install the lower jaw.

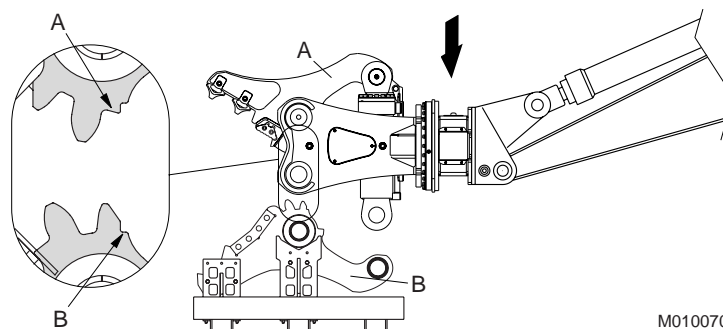

M010070

4. Make sure that the tothing of the jaws is aligned correctly.

Note! Do not operate the cutter-crusher jaws/cylinder with different pair of jaws!

- Turn the cutter-crusher around and remove the lower jaw.

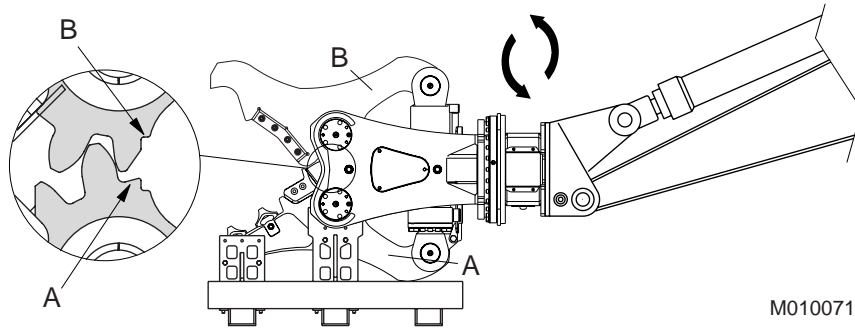

- Lower the cutter-crusher on the third assembling stand and install the lower jaw.

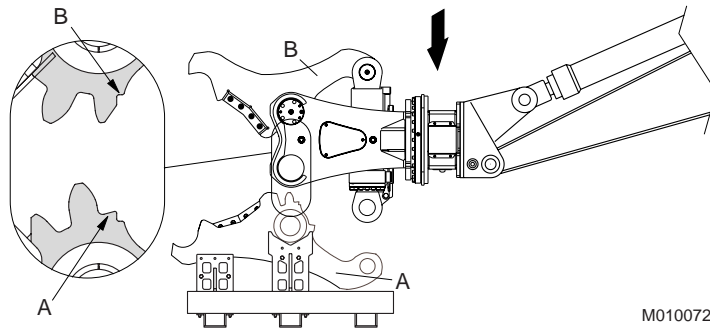

- Make sure that the tothing of the jaws is aligned correctly.

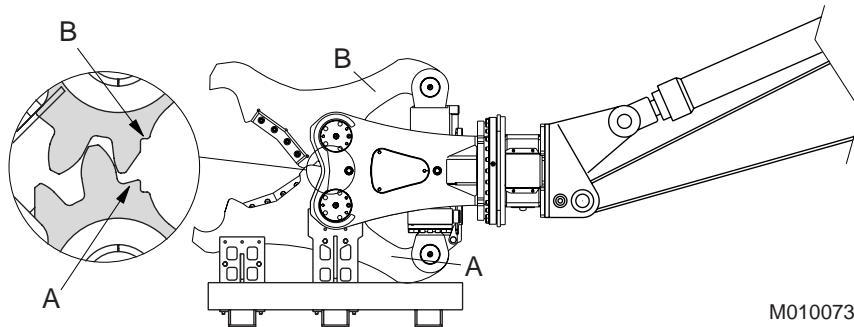

- Adjust the cutting blades according to the information in operation and maintenance manual.



## 6. OPERATION

---

### 6.1 OPERATING INSTRUCTIONS

---

#### RECOMMENDED USE

The cutter-crusher is designed for use in demolishing work to crush concrete and cut steel beams in buildings. Your local dealer will gladly give you more information.

#### OPERATING CONDITIONS

##### *Principles of installation*

Almost all carriers meeting mechanical and hydraulic requirements can be used to operate attachments. See “Product specifications” on page 74. The product is installed on the carrier much in the same manner as installing a bucket or other attachments. A flange mounted attachment requires also a separate mounting bracket.

The attachment is connected to a carrier's hydraulic circuit with an installation kit. If the carrier is already fitted with an installation kit, the installation requires only suitable hoses and fittings. For crusher installation, secondary relief valves in bucket cylinder circuit and in carrier auxiliary circuit are needed. If the carrier does not have suitable kit to run attachments, one must be built. This may require more complex installation including new piping and additional valves such as flow control valve or pressure relief valve.

Suitable kits can be ordered from the manufacturer or local dealers, from carrier manufacturers and their dealers or from third party suppliers.

##### *Hydraulic oil*

In general the hydraulic oil originally intended for the carrier can be used with this product. See “Requirements for hydraulic oil” on page 43.

##### *Operating temperature*

The operating temperature is -20 °C to 80 °C. If you must work in a temperature lower than -20 °C, the equipment has to be preheated before any operations can begin. Start the operation with low hydraulic flow.

Note: The temperature of the hydraulic oil must be monitored. Ensure that oil grade and monitored oil temperature together guarantee correct oil viscosity. See “Oil specifications” on page 44.

## **PRINCIPLES OF OPERATION**

The operation of the equipment is based on a static force produced by the hydraulic cylinder of the equipment. To increase the product's working life, pay particular attention to correct working methods.

Crushing is performed in the front of the crusher jaws. Avoid using cutting blades for crushing.

Cutting is performed with cutting blades at the rear of the crushing mouth. The cutting blades can be reversed.

## **CRUSHER JAWS, TEETH AND CUTTING BLADES**

### *Crusher jaws*

Crusher jaws are made of wear-resisting special steel. The jaws are operated by the hydraulic cylinder of the crusher and they open and close simultaneously.

### *Crushing teeth*

Crushing is performed using the crushing teeth of the jaws. The long-lasting convex shaped teeth are made of special steel. They are fastened with bolts and can be replaced.

### *Cutting blades*

The cutting blades are fastened with screws and can be turned, so that the unused cutting edge can be used, or replaced with new cutting blades.

The waved blade edges prevent steel beams from slipping from cutting blades.

## 6.2 DAILY OPERATION



Warning! Protect yourself and your surroundings from flying debris and collapsing concrete frames. Do not operate the cutter-crusher or carrier with people around it.



The cutter-crusher must not be used under water.

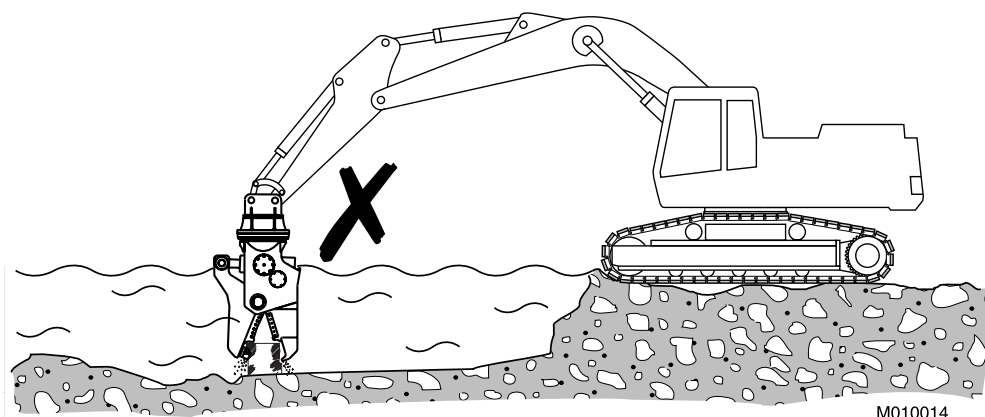

M010014



Warning! Cutting of steel cables or hardened steel wires with cutter-crusher may be difficult due to the flexibility of the material. The steel cable or hardened wire can be deflected or bent within the jaw area, and may cause serious damage to the cutter-crusher. Consult with your local dealer for more information.

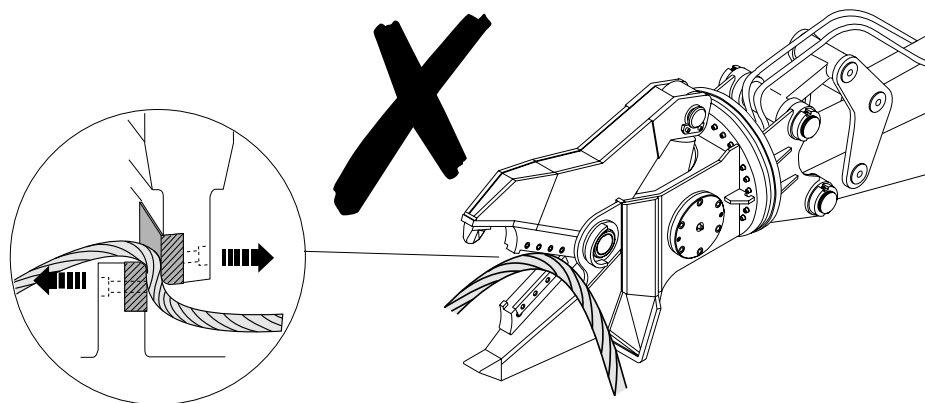

M010057

1. Prepare the carrier for normal excavation work. Move the carrier to the required position. Set the drive to neutral.

2. Set the engine speed to the recommended engine RPM.
3. Carefully operate the carrier controls to place the cutter-crusher and boom into the crushing position. Quick and careless boom movements could result in damage to the cutter-crusher.

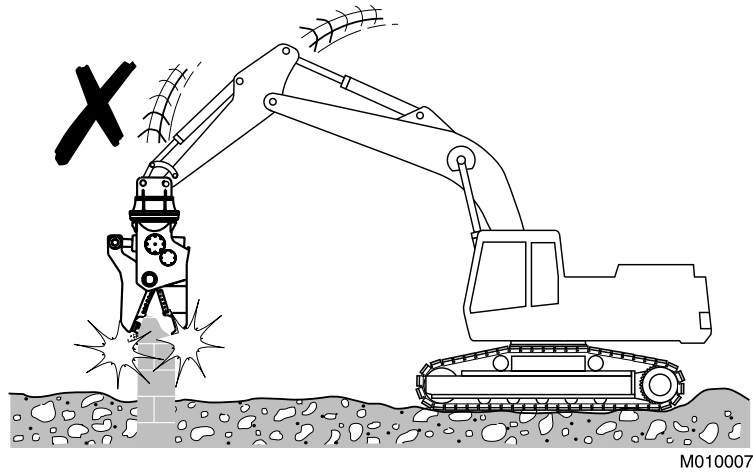

4. Open crusher jaws, position the object between the jaws and close the jaws to crush. When the crusher jaws are closed, a slewing function will work enabling crushing in right angle. The best crushing result is obtained by using the tooth area of the crusher jaws. Avoid crushing concrete with cutting blades.

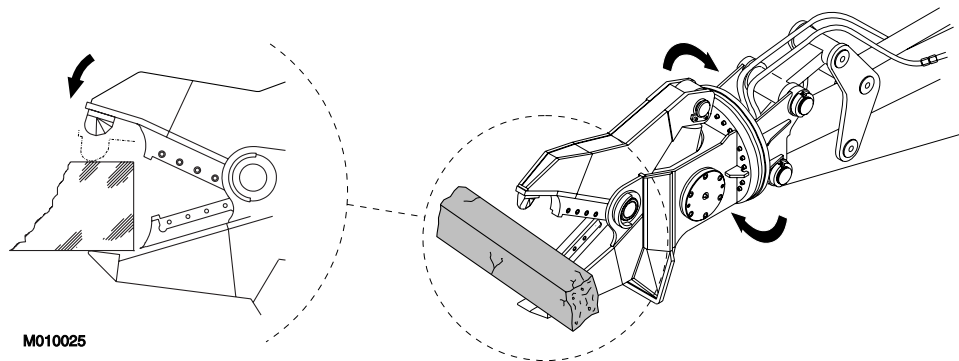

5. Use crusher teeth for crushing and cutting blades for cutting only.

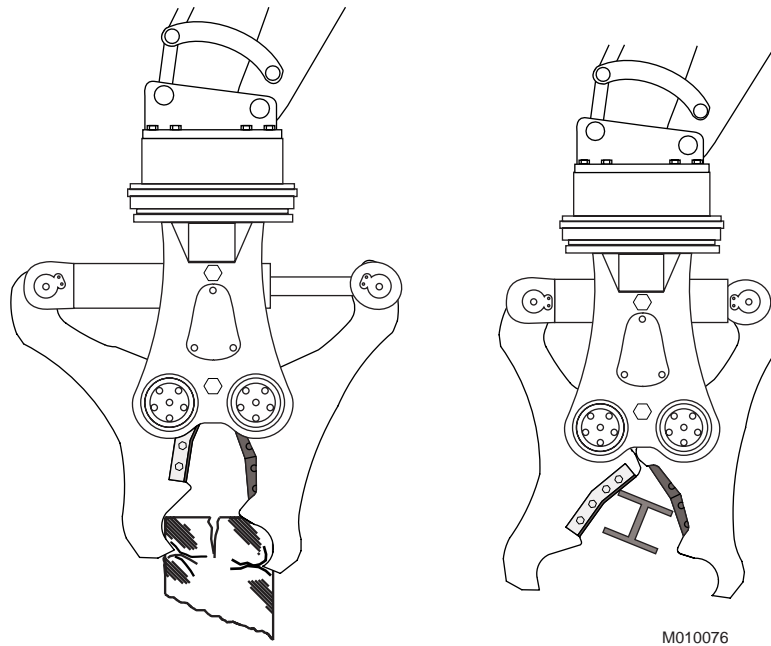

6. Concrete blocks can easily be demolished by first crushing in one point so that the structure breaks and then crushing in another point to multiple fractures. Finish demolition by crushing and cutting between the two points. Note: When demolishing prestressed concrete blocks, be careful not to damage the crusher on extra hard steel ribbons inside the concrete.

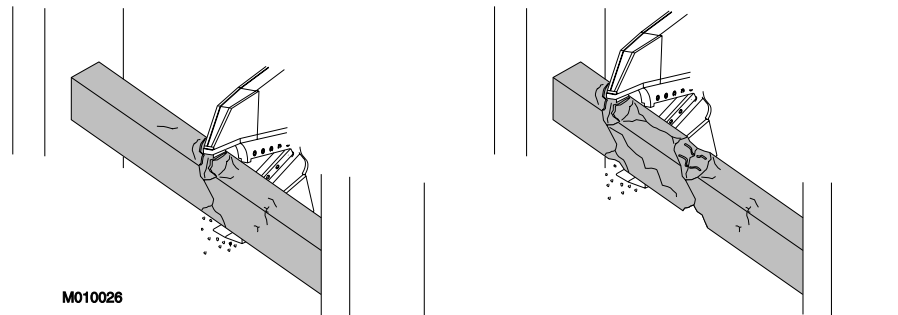

7. A safety screen is recommended to protect the operator from flying debris. Keep the cabin windows and doors closed during operation.

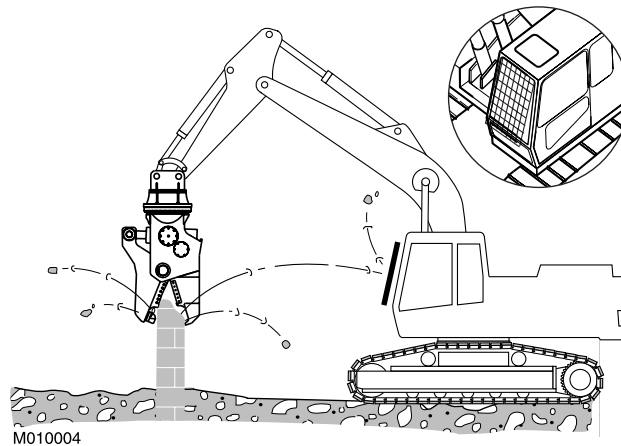

8. To cut, position the object between the cutting blades and close the jaws. When the crusher jaws close, a slewing function will work enabling cutting in right angle.

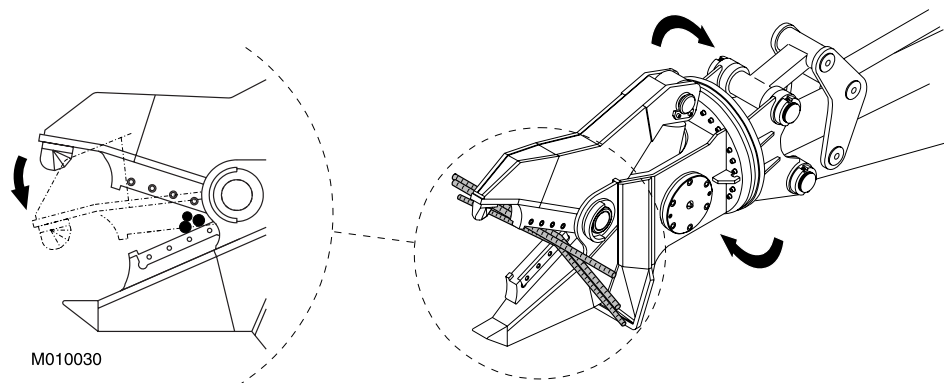

9. When cutting horizontal steel frames, concentrate the shearing action at the proper working angle. Cut through in one point at the other end of the frame. Cut partially through in another point. Then bend the framework down using the cutter-crusher and make final cut.

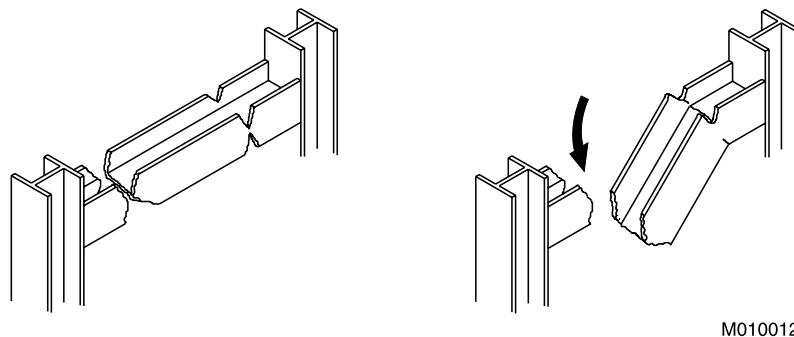

10. Place steel frames properly between cutting blades, as shown in the illustration. Note: If the cutting object does not fit into the crusher mouth, first press it between the jaws to flatten it and then perform final cutting with cutting blades.

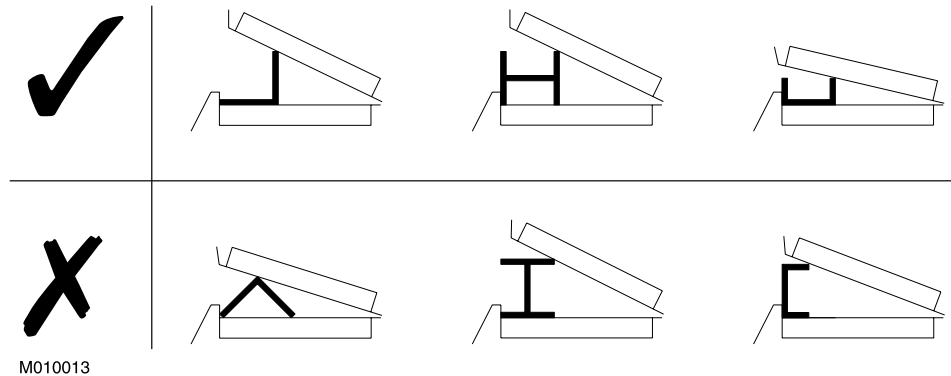

11. Place steel frames deep between cutting blades. Feed force is critical for proper working result.

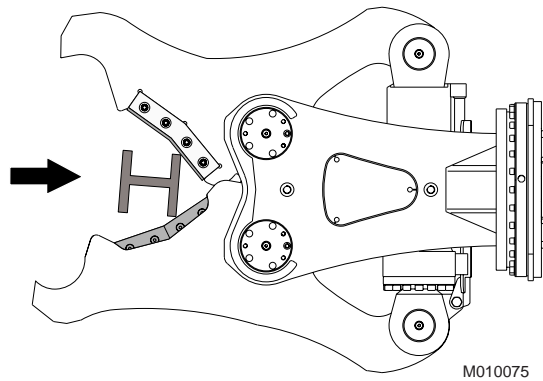

12. Make sure the metal object is fully between the cutting blades.

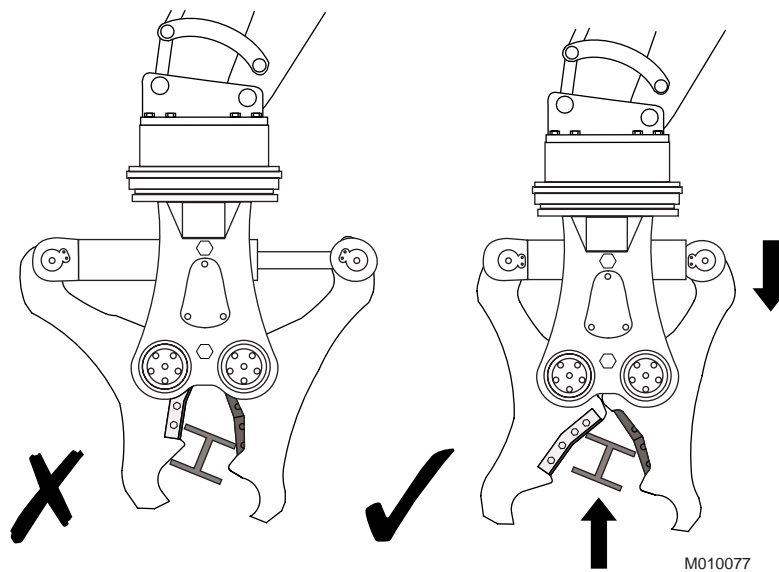

13. A large metal beam may need several bites. Sufficient feed force is important for proper working result.

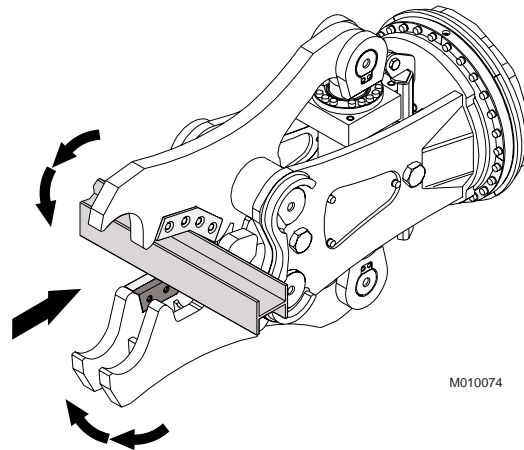

14. As a rule, when the angle between the upper and lower cutting blade is less than 30 degrees the object will not slip.
15. The cutter-crusher is intended for cutting and crushing, do not use the cutter-crusher as a lever or to strike, hit or ram objects. Do not use the side of the cutter-crusher to move concrete or objects.
16. Do not use cutter-crusher for lifting. Lifting eyes on the cutter-crusher are for storage and maintenance purposes only.

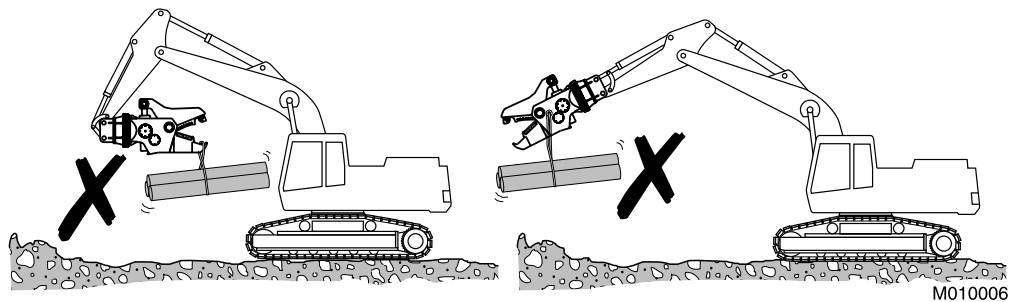

17. Do not use cutter-crusher for moving excavator.

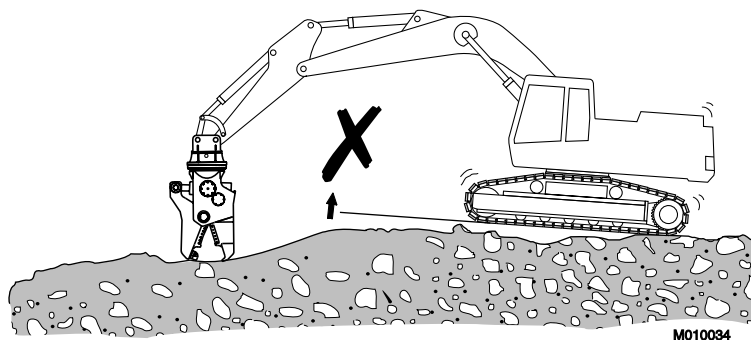



18. When operating the cutter-crusher, make sure that it does not make contact with the carrier boom or hydraulic lines.

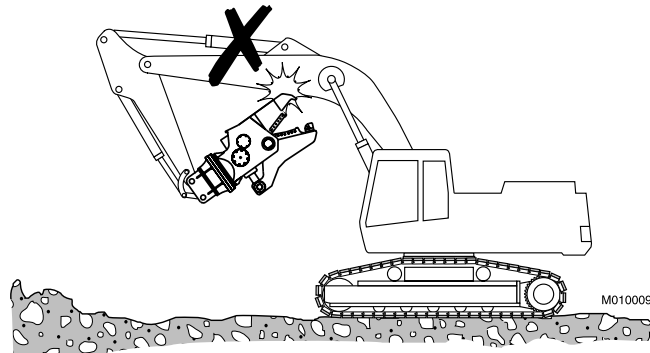

19. Do not operate crusher jaws with the carrier's boom stick or bucket cylinders at the end of their stroke (either fully extended or retracted). Damage to the carrier may result.

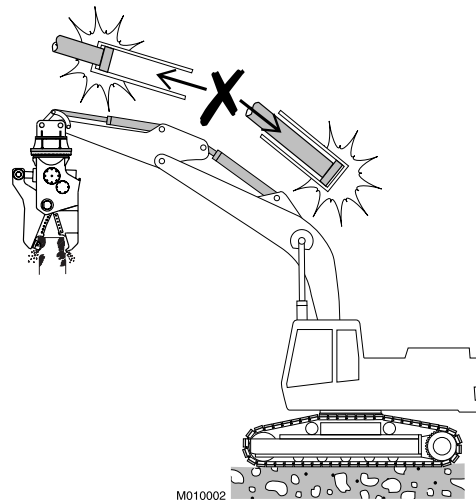

20. When the crusher jaws are closed, the cylinder rod is exposed. The operator must take care not to hit the rod with concrete or iron bars. Damage to the cylinder rod may cause rod seal breakage and oil leaks.

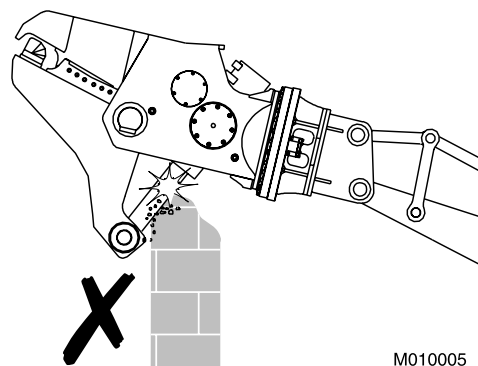

21. Getting steel frame or rebar between crusher jaws and cylinder rod clevis can cause damage to the cylinder rod or crusher jaws. To avoid cylinder damage, always remove demolition debris from the housing.

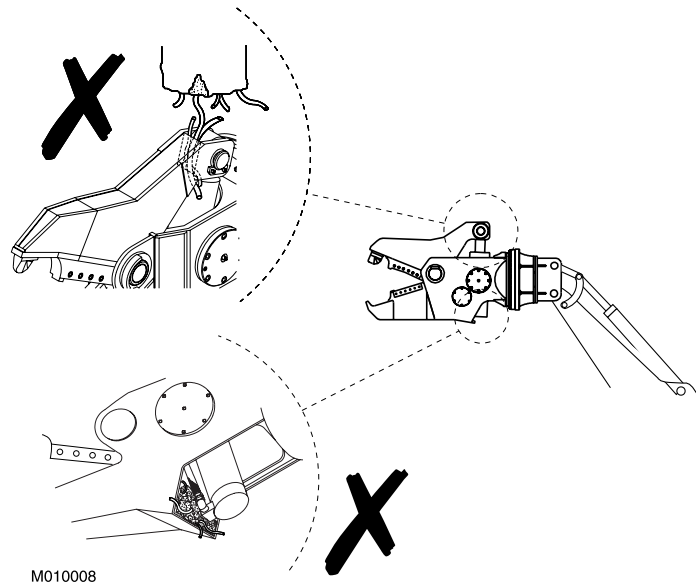

22. Do not operate excavator hydraulic cylinders when the crusher jaws are closed. Bending the object up and down when the cutter-crusher jaws are pressed on it may cause excessive wearing of cutter-crusher teeth and cutting blades.

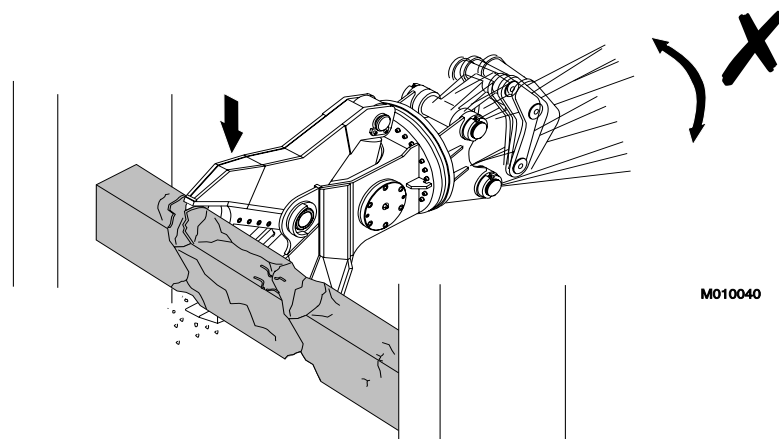

23. The bearings must be well greased during operation. Regular inspections during operation are recommended. If no grease is visible, bearings require more frequent greasing. Bearings covered with excessive grease require less frequent greasing.

## 6.3 MOUNTING AND DISMOUNTING THE EQUIPMENT

### REMOVAL FROM CARRIER



**Warning!** The equipment must be secured from rolling over when disconnecting from the carrier. Only use skilled operator to position carrier for the removal!

**Warning!** Hydraulic pressure inside the equipment must always be released before opening hose connections!

**Warning!** Hot hydraulic fluid can cause severe injuries!

1. Position attachment horizontally on the floor.
2. Stop the carrier engine. Operate boom and attachment controls to release pressure trapped inside hoses.
3. Close attachment shut-off valve. If quick couplers are used, disconnection automatically closes attachment lines. If the line includes ball valves, please make sure that they are closed.
4. Disconnect hoses. Protect environment from oil spills. Plug the hoses.
5. Remove bucket pins and other parts.

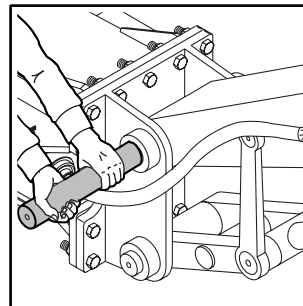
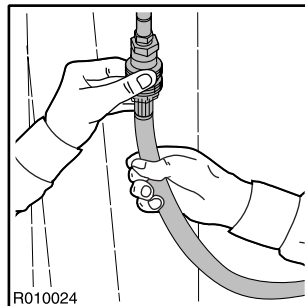

6. The carrier can be moved aside.

## INSTALLATION



**Warning!** The residual air in the hoses must always be removed before operation!

1. Install equipment in the same manner as mounting a bucket. Install bucket pins.
2. Connect hoses. An installation inspection must be carried out after the product has been mounted on the carrier. In the installation inspection certain specifications (operating pressure, oil flow, etc.) are checked so that they are within given limits. See “Product specifications” on page 74.
3. Open the ball valves.
4. Remove air from the hoses by carefully operating the crusher cylinder. Open and close empty jaws several times.

## 6.4 MOVEMENT

The transportation and parking positions are shown below. When moving the carrier, ensure that the crusher is not too close to the carrier.

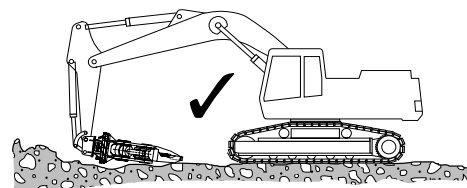
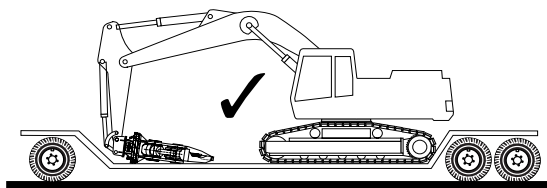
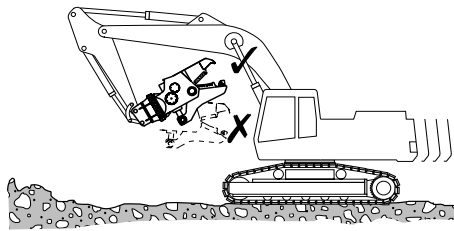

M010043

## 6.5 SPECIAL CONDITIONS OF USE

---

The equipment may require modifications, special operating techniques, increased maintenance or special wear items if it is used in conditions that differ from normal breaking or demolition work. Special conditions of use are:

- Operations in extremely low or high temperatures
- Use of special hydraulic fluids
- Operations with special carrier
- Other special conditions

In case of special conditions of use, please consult your local dealer for instructions.



The cutter-crusher must not be used under water.

## 6.6 STORAGE

---

### LONG TERM STORAGE

Observe the following points when the product is stored. In this way the vital parts of the attachment are protected from rust and the machine is ready to be used whenever necessary.

1. The storage area must be dry.
2. To avoid damaging the cylinder rod, operate the cylinder to the shortest position by leaving the crusher jaws open.
3. Insert blocks under the crusher to keep it off the ground. If the machine is stored outside, cover it to prevent rusting.

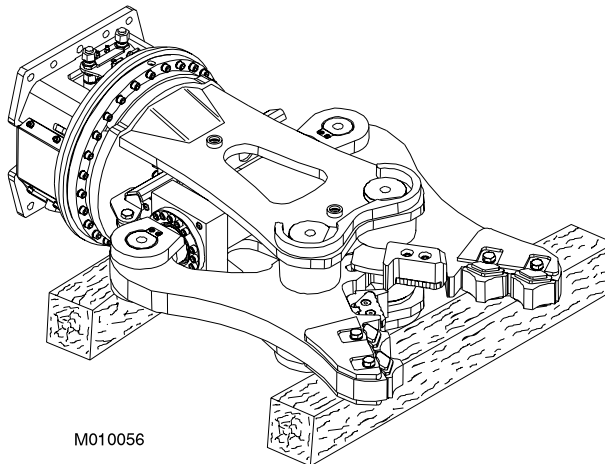

M010056

4. Apply grease to all crusher parts. Protect mounting bracket, pin holes, cutting blades and pivot ends with an anticorrosive agent.
5. Connections must be sealed with clean plugs to prevent oil leakage and dirt from getting into couplings.
6. Make sure the product can not fall.

---

# LUBRICATION

---

# I. GREASING

## I.1 RECOMMENDED GREASES

Item	Recommended greases	Greasing interval
Crusher pins and bushings	ESSO Beacon EP2	every 8 hours
	SHELL Retinax EP2	
	FUCHS Lubritech, Lagermeister EP 2	
	MOBIL Mobilux EP 2	
Slew bearing	ESSO Beacon EP2	every 150 hours
	SHELL Retinax EP2	
	FUCHS Lubritech, Lagermeister EP 2	
	MOBIL Mobilux EP 2	
Slew gear	ESSO Dynagear	every 8 hours
	SHELL Malleus GL95	
	FUCHS Lubritech, Ceplattyn 300	
	MOBIL Mobiltac 81	

## I.2 GREASING POINTS



Follow the product's greasing instructions and avoid excessive greasing. Dispose of empty grease containers appropriately.

The greasing points of the crusher have been marked with the following sticker.

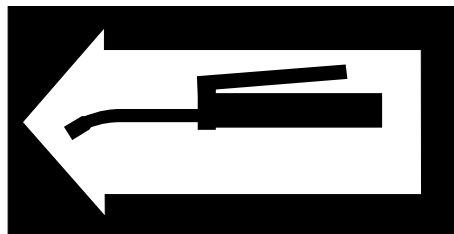

R020002



The greasing points of the crusher are shown below.

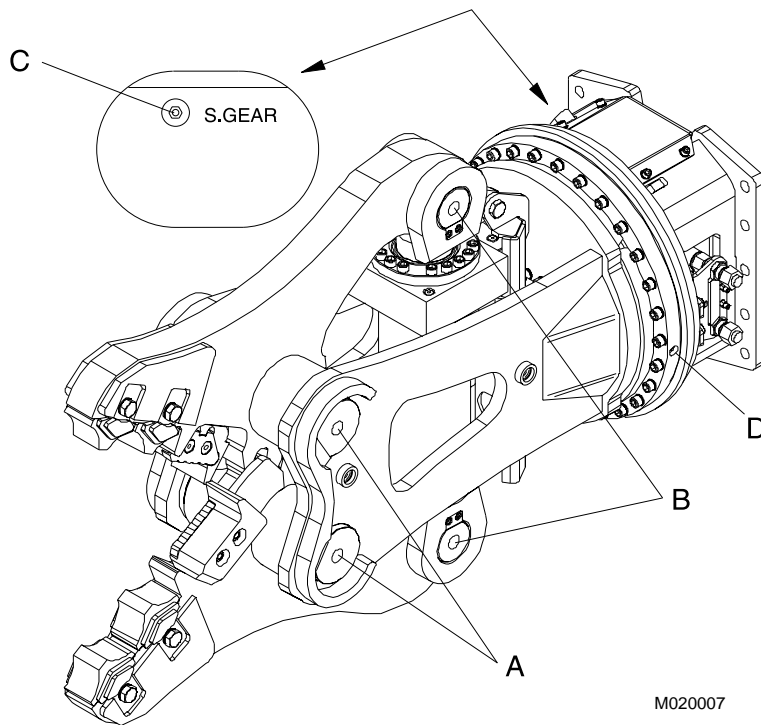

- A. Trunnion
- B. Rod pin
- C. Slew gear (S.GEAR)
- D. Slew bearing

### CRUSHER PARTS

1. Always grease before operation and after every 8 hours of operation.
  2. Adapt greasing interval and amount of grease to working conditions.
- Insufficient greasing or improper grease may cause abnormal wear of parts.

### SLEW GEAR

1. Always grease before operation and after every 8 hours of operation.
2. Adapt greasing interval and amount of grease to working conditions.
3. Apply grease from grease gun to grease nipples. It is important to rotate the slewing ring during lubrication. Complete the lubrication after rotation.

Insufficient greasing or improper grease may cause abnormal wear of parts.

Note: Use only gear grease for slew gear.

**SLEW BEARING**

1. Grease adequately after every 150 hours of operation.
2. Adapt greasing interval and amount of grease to working conditions.
3. Apply grease from grease gun to grease nipples. It is important to rotate the slewing ring during lubrication. Complete the lubrication after rotation.

Insufficient greasing or improper grease may cause abnormal wear of parts.

Note: Use only grease specified for slew bearing.

## 2. CARRIER HYDRAULIC OIL

---

### 2.1 REQUIREMENTS FOR HYDRAULIC OIL

---

#### GENERAL REQUIREMENTS

In general the hydraulic oil originally intended for the carrier can be used with this product. However, since working with the product heats the oil more than the usual excavation work, the temperature of the oil must be monitored.

If the temperature of the hydraulic oil exceeds 80 °C, an auxiliary oil cooler is needed. The oil viscosity must be between 1000-20 cSt while the attachment is being used.

When the product is used continuously, the temperature of the hydraulic oil normalizes at a certain level depending on conditions and on the carrier. The temperature in the tank must not exceed the maximum allowed.

The attachment must not be started if the ambient temperature is below freezing and the oil is very thick. The machine must be moved to bring the oil temperature above 0 °C before working can start (viscosity 1000 cSt or 131 °E).

**OIL SPECIFICATIONS**

Table below shows hydraulic oils recommended for equipment use. The most suitable oil is selected in such a way that the temperature of the hydraulic oil in continuous use is in the ideal area on the chart and the hydraulic system is used to best advantage.

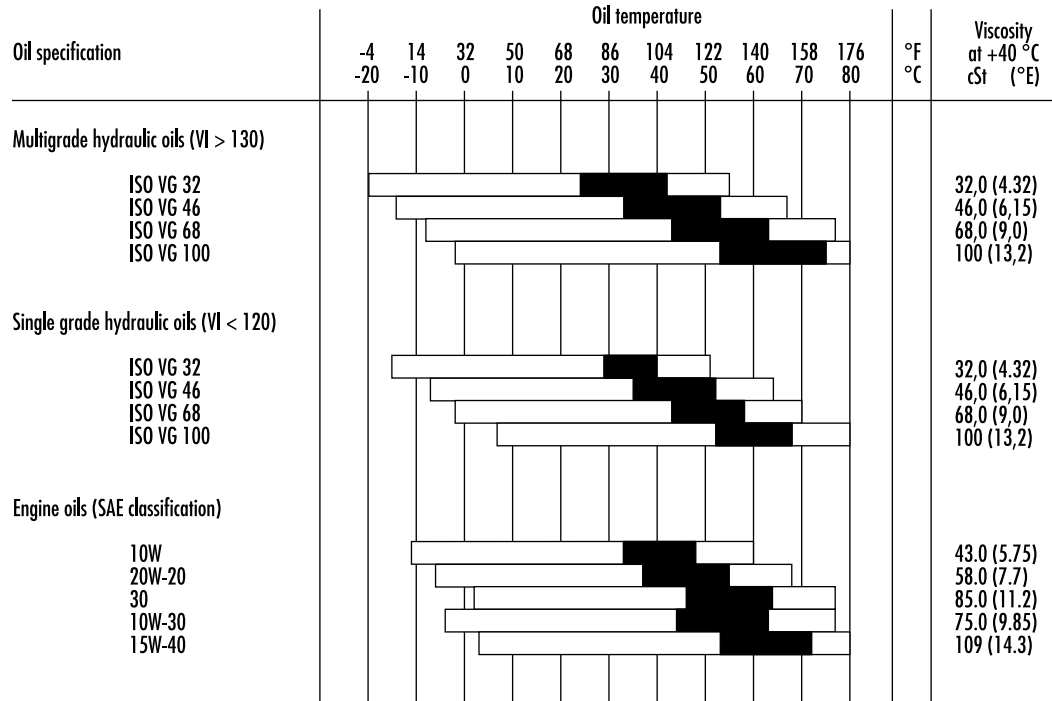

VI = Viscosity index  
 □ Permitted oil temperature  
 ■ Recommended oil temperature

R020004

Problems due to incorrect hydraulic oil viscosity in the equipment:

***Oil too thick***

- Difficult start up
- Stiff operation
- Danger of cavitation
- Sticky valves
- Filter bypass opens, impurities in the oil are not removed

***Oil too thin***

- Efficiency losses (internal leaks)
- Damage to gaskets and seals, leaks
- Accelerated wearing of parts, because of decreased lubrication efficiency
- Danger of cavitation

Note: We strongly recommend the use of different hydraulic oils in the summer and in the winter if there is an average temperature difference of more than 35 °C. The correct hydraulic oil viscosity is thus ensured.

### **SPECIAL OILS**

In some cases special oils (e.g. biological oils and non-inflammable oils) can be used with the crushers. Observe the following aspects when considering the use of special oils:

- The viscosity range in the special oil must be in the given range (20-1000 cSt)
- The lubrication properties must be sufficient
- The corrosion resistance properties must be good enough

Note: Although a special oil could be used in the carrier, always check its suitability with the attachment. Contact the oil manufacturer or your local dealer for more information about special oils.

## **2.2 OIL COOLER**

---

The carrier hydraulic system must be able to maintain the temperature within an acceptable level during the crusher operation. This is for two reasons.

1. Seals, wipers, membranes and other parts manufactured from the corresponding materials can normally stand temperatures up to 80 °C.
2. The higher the temperature is, the less viscous the oil gets thus losing its capability to lubricate.

A standard carrier, with a proper crusher circuit, meets the requirements of the necessary cooling capacity. If the oil temperature tends to be too high during the crusher operation, the following things must be checked:

- The crusher circuit pressure relief valve should not be opened unnecessarily.
- The crusher circuit pressure drops must be reasonable, less than 20 bar in the hydraulic line.
- There should be no internal leakages in crusher or in carrier hydraulic pumps, valves, cylinders, motors, etc.

If all of the above mentioned things are in order, and the temperature of the hydraulic oil still tends to be too high, extra cooling capacity is needed. Consult the carrier manufacturer or dealer for details.

## 2.3 OIL FILTER

---

The purpose of the oil filter is to remove impurities from the hydraulic oil. Air and water are also impurities in oil. Not all impurities can be seen with the naked eye.

Impurities enter the hydraulic system:

- During hydraulic oil changes and refilling.
- When components are repaired or serviced.
- When the attachment is being installed on the carrier.
- Because of component wear.

Normally the existing main oil filters of the carrier are used as attachment circuit return line filters. Consult the carrier manufacturer or your local dealer concerning instructions for the filter change intervals.

In crusher work the carrier oil filter must fulfil the following specifications:

- The oil filter must allow maximum particle size of 25 microns (0.025 mm).
- The oil filter material must be man-made fibre cloth or very fine gauge metallic mesh to withstand pressure fluctuations.
- The oil filter must have a nominal flow capacity of at least twice the attachment's maximum flow.

In general, oil companies guarantee new oils to have a particle count of 40 microns maximum. Filter the oil when filling the tank.

The damage caused by hydraulic oil impurities in the carrier and attachment circuits:

### *Shortened working life of pumps and other components*

- Rapid wear of parts.
- Cavitation.
- Wear of cylinder and gaskets.

### *Reduced attachment efficiency*

- Accelerated wear of moving parts and seals.
- Oil leakages.

### *Shortened working life and reduced lubricating capability of oil*

- Overheated oil.
- Deteriorated oil quality.
- Electro-chemical changes in hydraulic oil.

*Malfunction of valves*

- Binding spools.
- Rapid wear of parts.
- Blocking of small holes.

Note: Component damage is only a symptom. The trouble itself will not be cured by removing the symptom. After any component damage due to impurities in the oil, the entire hydraulic system has to be cleaned. Dismantle, clean and reassemble the crusher and change the hydraulic oil.





---

# MAINTENANCE

---

# I. ROUTINE MAINTENANCE

---

## I.1 OVERVIEW

---

This product is a precision made hydraulic machine. Therefore great care and cleanliness should be taken when handling any of the hydraulic components. Dirt is the worst enemy in hydraulic systems.

Handle the parts carefully and remember to cover any cleaned and dried parts with clean lint-free cloth. Do not use anything other than purpose designed materials for cleaning hydraulic parts. Never use water, paint thinners or carbon tetrachloride.

Components, gaskets and seals in the hydraulic system should be oiled with clean hydraulic oil before assembly.

Remember to grease the crusher parts regularly according to the instructions in this manual. See “Greasing” on page 40.

Close the crusher jaws during maintenance or inspection. If you must leave the jaws open, remember to block the jaws to prevent them from closing.

Prior to maintenance or inspection, operate all the control levers to their fully extended stroke. This will release pressure within the hydraulic piping and prevent unexpected movement of the jaw and loss of oil through the hydraulic lines.

## I.2 INSPECTION AND MAINTENANCE BY THE OPERATOR

---

Note: The times given refer to the carrier hours while the attachment is installed.

### EVERY EIGHT HOURS

Grease main shaft, trunnion, rod pin and slew gear.

### DAILY MAINTENANCE

1. Check the hydraulic hoses and hose connections. Tighten if necessary.
2. Check the cutting blades and their clearance. Tighten bolts or replace the cutting blades, if necessary. See “Turning and changing cutting blades” on page 53. See “Turning and changing cutting blades” on page 56. See “Turning and changing cutting blades” on page 59.

3. Check the crusher jaws and teeth for wear and fastening. Tighten teeth bolts or replace teeth, if necessary. See “Replacing crusher teeth” on page 62.
4. Check the grease nipples.

### **WEEKLY MAINTENANCE**

1. Check the main body for wear.
2. Check the pins and bushings for wear.
3. Check cylinder rod, seals and connection points for wear. Tighten if necessary.
4. Observe hydraulic oil temperature, all lines and connections.
5. Check that the crusher works smoothly by operating the jaws.
6. Tighten connections, if necessary.

### **EVERY 150 HOURS**

Grease slew bearing.

## **I.3 INSPECTION AND MAINTENANCE BY THE DEALER**

---

Note: The times given refer to the carrier hours while the attachment is installed.

### **INITIAL 50-H INSPECTION**

It is recommended to have the first inspection done by your local dealer after 50 to 100 operating hours. Contact your local dealer for more information about the initial 50-hour inspection.

### **EVERY 600 HOURS OR ONCE A YEAR**

This service is recommended to be done by your local dealer after 600 operating hours. Neglecting the yearly service can cause severe damage to the crusher.

Your local dealer will reseal the crusher and replace safety decals as needed. Contact your local dealer for more information about yearly servicing.

During this maintenance you should do the following tasks.

- Check all hydraulic connections.
- Check that the hydraulic hoses do not rub against anything in any boom/stick position.

## **I.4 MAINTENANCE INTERVALS IN SPECIAL APPLICATIONS**

---

The service interval is considerably shorter with special applications. See “Special conditions of use” on page 37. In special applications, please consult your local dealer for the correct service intervals.



The cutter-crusher must not be used under water.

## **I.5 OTHER MAINTENANCE PROCEDURES**

---

### **WASHING THE ATTACHMENT**

When working with attachment and removing it from the carrier, dirt (mud, rock powder, etc.) can become attached to it. Wash the outside of the product with a steam washer before sending it to the workshop. Dirt can cause difficulties in disassembly and assembly otherwise.

**CAUTION!** Plug the pressure and return line before washing the product or else dirt can enter into it and this may cause damage to the components.

## 2. TURNING AND CHANGING CUTTING BLADES

### WEAR LIMITS, ADJUSTMENTS AND TORQUES FOR CUTTING BLADES

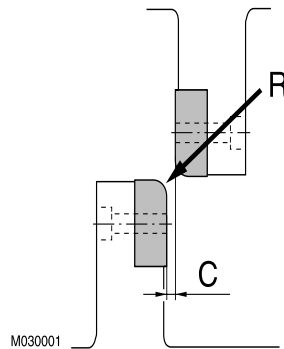

Item	Wear limit
Cutting blade edge (R)	3 mm
Item	Adjustment
Cutting blade clearance (C)	0.2...0.7 mm
Item	Tightening torque
Cutting blade screws	85 Nm

## REMOVAL OF CUTTING BLADES



**Warning!** Prior to maintenance or inspection, operate all the control levers to their fully extended stroke. This will release pressure within the hydraulic piping and prevent unexpected movement of the jaw and loss of oil through the hydraulic lines.

**Warning!** Support the crusher jaw to prevent it from closing unexpectedly during maintenance.

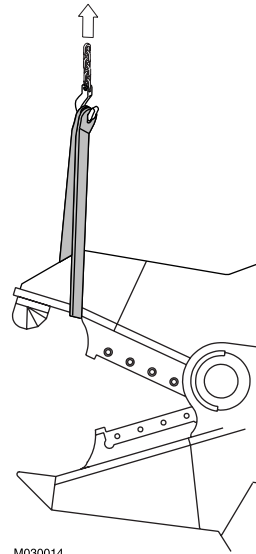

M030014



**Used cutting blades can be recycled. Contact your dealer for more information about local regulations of recycling.**

1. Position the attachment on level ground.
2. Support the crusher jaw.
3. Make sure the carrier's transmission is in neutral and the parking brake is engaged.
4. Stop the carrier engine.
5. Clean the cutting blades and the base.
6. Open hex socket-head screws. Remove screws, nuts and lock washers.

- Remove cutting blades and shim plates.

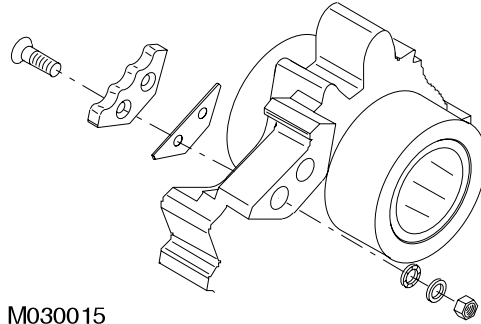

- Finish the surfaces by grinding, flush all burrs from cutting blade and cutter base.

Note: If burrs remain on the surface the cutting blade will not have proper contact with the cutter base. This will cause breakage of the cutting blade.

### INSTALLATION OF CUTTING BLADES

- Reverse the cutting blade so that unused edge can be used or install a new cutting blade.
- Set cutting blade on the base.
- Fit cutting blade into cutter base with screws, lock washers and nuts.
- Use a plastic hammer to seat cutting blade into its place with proper contact.
- Close crusher jaws and measure the clearance between cutting blades.
- Adjust the clearance (C) between cutting blades according to specifications. If necessary add or remove shim plates.

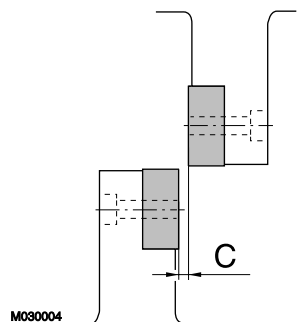

- Torque screws to the specified setting.

# 3. TURNING AND CHANGING CUTTING BLADES

## WEAR LIMITS, ADJUSTMENTS AND TORQUES FOR CUTTING BLADES

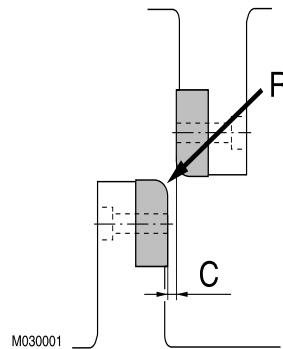

Item	Wear limit
Cutting blade edge (R)	3 mm
Item	Adjustment
Cutting blade clearance (C)	0.2...0.7 mm
Item	Tightening torque
Cutting blade screws	210 Nm



## REMOVAL OF CUTTING BLADES



Prior to maintenance or inspection, operate all the control levers to their fully extended stroke. This will release pressure within the hydraulic piping and prevent unexpected movement of the jaw and loss of oil through the hydraulic lines.

**Warning!** Support the crusher jaw to prevent it from closing unexpectedly during maintenance.

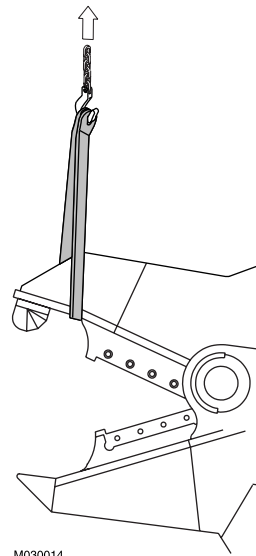

M030014



**Used cutting blades can be recycled. Contact your dealer for more information about local regulations of recycling.**

1. Position the attachment on level ground.
2. Support the crusher jaw.
3. Make sure the carrier's transmission is in neutral and the parking brake is engaged.
4. Stop the carrier engine.
5. Clean the cutting blades and the base.
6. Open hex socket-head screws. Remove screws, nuts and lock washers.

- Remove cutting blades and shim plates.

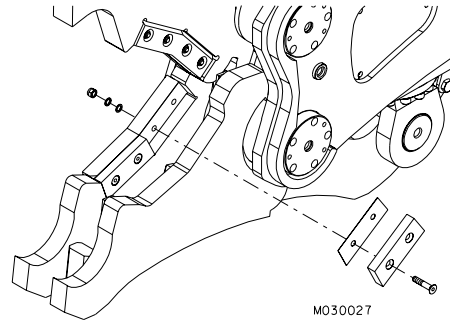

- Finish the surfaces by grinding, flush all burrs from cutting blade and cutter base.

Note: If burrs remain on the surface the cutting blade will not have proper contact with the cutter base. This will cause breakage of the cutting blade.

### INSTALLATION OF CUTTING BLADES

- Reverse the cutting blade so that unused edge can be used or install a new cutting blade.
- Set cutting blade on the base.
- Fit cutting blade into cutter base with screws, lock washers and nuts.
- Use a plastic hammer to seat cutting blade into its place with proper contact.
- Close crusher jaws and measure the clearance between cutting blades.
- Adjust the clearance (C) between cutting blades according to specifications. If necessary add or remove shim plates.

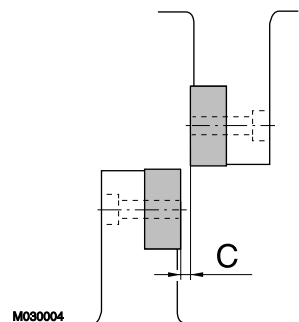

- Torque screws to the specified setting.

# 4. TURNING AND CHANGING CUTTING BLADES

## WEAR LIMITS, ADJUSTMENTS AND TORQUES FOR CUTTING BLADES

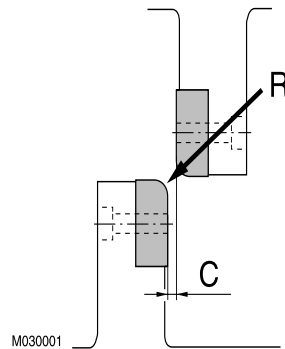

Item	Wear limit
Cutting blade edge (R)	3 mm
Item	Adjustment
Cutting blade clearance (C)	0.2...0.7 mm
Item	Tightening torque
Cutting blade screws	210 Nm

## REMOVAL OF CUTTING BLADES



Prior to maintenance or inspection, operate all the control levers to their fully extended stroke. This will release pressure within the hydraulic piping and prevent unexpected movement of the jaw and loss of oil through the hydraulic lines.

**Warning!** Support the crusher jaw to prevent it from closing unexpectedly during maintenance.

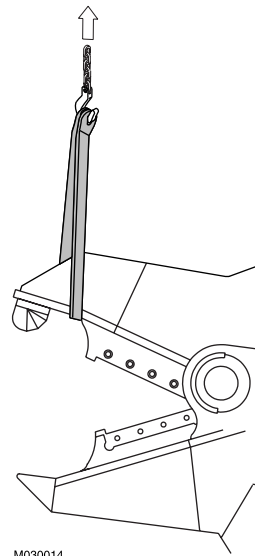

M030014



**Used cutting blades can be recycled. Contact your dealer for more information about local regulations of recycling.**

1. Position the attachment on level ground.
2. Support the crusher jaw.
3. Make sure the carrier's transmission is in neutral and the parking brake is engaged.
4. Stop the carrier engine.
5. Clean the cutting blades and the base.
6. Open hex socket screws. Remove screws and lock washers.

- Remove cutting blades and shim plates.

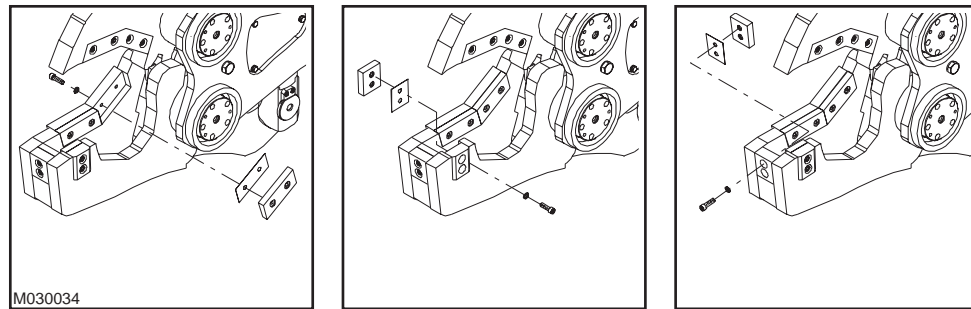

- Finish the surfaces by grinding, flush all burrs from cutting blade and cutter base.

Note: If burrs remain on the surface the cutting blade will not have proper contact with the cutter base. This will cause breakage of the cutting blade.

### INSTALLATION OF CUTTING BLADES

- Reverse the cutting blade so that unused edge can be used or install a new cutting blade.
- Set cutting blade on the base.
- Fit cutting blade into cutter base with screws and lock washers.
- Use a plastic hammer to seat cutting blade into its place with proper contact.
- Close crusher jaws and measure the clearance between cutting blades.
- Adjust the clearance (C) between cutting blades according to specifications. If necessary add or remove shim plates.

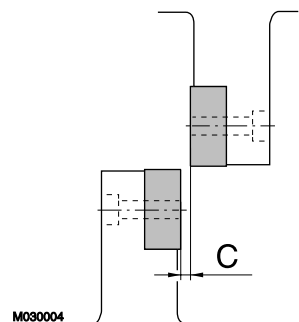

- Torque screws to the specified setting.

## 5. REPLACING CRUSHER TEETH

### TIGHTENING TORQUE FOR CRUSHER TOOTH

Item	Tightening torque
Crusher tooth screw	690 Nm

### REMOVAL OF CRUSHER TOOTH



**Warning!** Support the crusher jaw to prevent it from closing unexpectedly during maintenance.



**A used crusher tooth can be recycled. Contact your dealer for more information about local regulations of recycling.**

1. Position the attachment on level ground.
2. Support the crusher jaws.
3. Clean the crushing tooth and the base.
4. Open and remove screw, lock washers and nut.
5. Remove tooth.

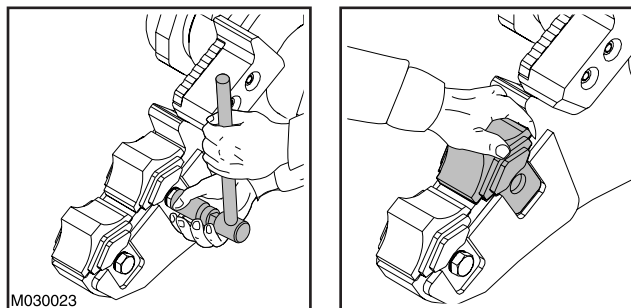

### INSTALLATION OF CRUSHER TOOTH

1. Clean all parts carefully.
2. Install tooth.
3. Install screw, lock washers and nut.

4. Check that tooth is seated properly. Torque screw and nut to the specified setting.

# 6. REPLACING WOOD CUTTING TEETH

## TIGHTENING TORQUE FOR WOOD CUTTING TOOTH

Item	Tightening torque
Wood cutting tooth screw	690 Nm

## REMOVAL OF WOOD CUTTING TOOTH



**Warning!** Support the crusher jaw to prevent it from closing unexpectedly during maintenance.



**A used cutting tooth can be recycled. Contact your dealer for more information about local regulations of recycling.**

1. Position the attachment on level ground.
2. Support the crusher jaws.
3. Clean the wood cutting tooth and the base.
4. Open and remove screws, lock washers and nuts.
5. Remove tooth.

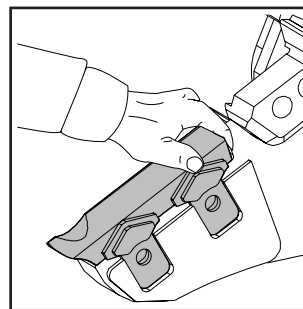
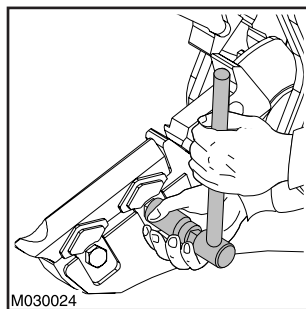

## INSTALLATION OF WOOD CUTTING TOOTH

1. Clean all parts carefully.
2. Install tooth.



3. Install screws, lock washers and nuts.
4. Check that tooth is seated properly. Torque screws to the specified setting.

## 7. REPLACING CRUSHING PLATE

### TIGHTENING TORQUE FOR PULVERIZING PLATE

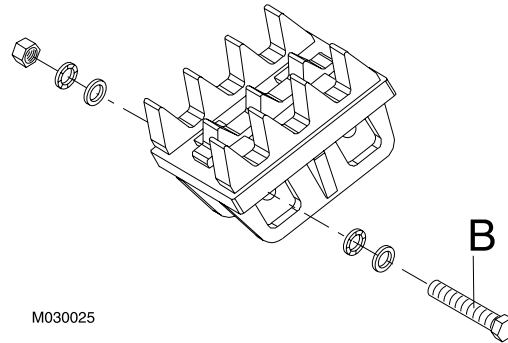

Item	Tightening torque
Pulverizing plate screws (B)	690 Nm

### REMOVAL OF PULVERIZING PLATE



**Warning!** Support the crusher jaw to prevent it from closing unexpectedly during maintenance.



**A used pulverizing plate can be recycled. Contact your dealer for more information about local regulations of recycling.**

1. Position the attachment on level ground.
2. Support the crusher jaws.
3. Clean the pulverizing plate and the base.
4. Open and remove screws, lock washers and nuts.

5. Remove pulverizing plate.

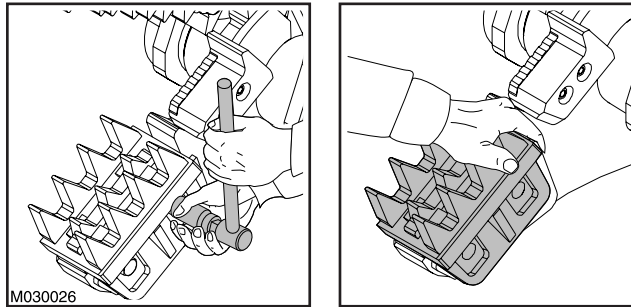

### INSTALLATION OF PULVERIZING PLATE

1. Clean all parts carefully.
2. Install pulverizing plate.
3. Install screws, lock washers and nuts.
4. Check that pulverizing plate is seated properly. Torque screws to the specified setting.

# 8. REPLACING JAWS GUIDE PLATES

## WEAR LIMITS FOR GUIDE PLATES

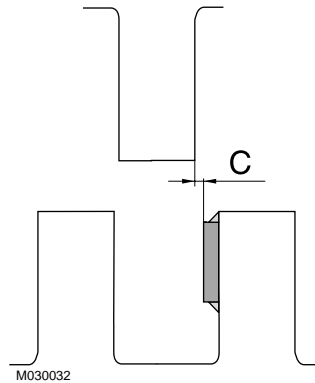

Item	Adjustment
Clearance between upper jaw and guide plate (worn out) (C)	2.0 mm

## WELDING TOOLS

Item	Welding tool
Repair of parent, installation of tooth	MIG-wire, DIN 8559: SG 2
	Welding rod, DIN 1913: E 51 53 B 10
Hardfacing	MIG-wire, DIN 8555: SG 6 - 60
	Welding rod, DIN 8555: E 6 - 55

## REMOVAL OF GUIDE PLATES



Welding must occur in a workshop with proper welding tools. If you must weld the crusher when it is installed in carrier, consult your carrier dealer for precautions during welding.

**Warning!** Support the crusher jaw to prevent it from closing unexpectedly during maintenance.

1. Position the attachment on level ground.
2. Support the crusher jaws.
3. Check the clearance between crusher jaw and guide plates. Change guide plates if clearance is more than specified.
4. Cut off the worn part by carbon arc gouging or by gas cutting at the base. Note: Connect earth cable to the part to be repaired.
5. Repair parent by filling it with welding rod, and finish the surface by grinding.
6. Make edge preparation on the body side.

## INSTALLATION OF GUIDE PLATES

1. Tack the new part with welding rod. Note: Connect earth cable to the part to be repaired.
2. Preheat the jaw and the part to 100 °C...150 °C.
3. Perform welding.
4. Close the crusher jaws to make sure that the clearance between guide plates and upper jaw are right, use grinding machine if necessary.

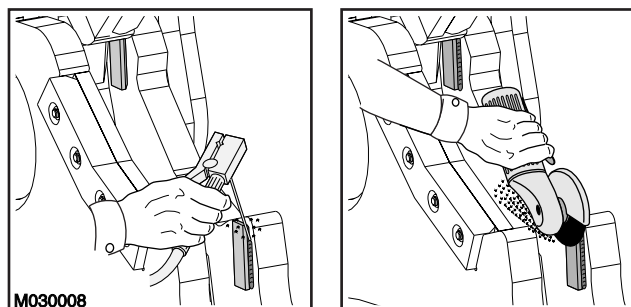

## 9. TROUBLESHOOTING

---

### 9.1 MACHINE DOES NOT CRUSH

---

#### **WORN CRUSHER TEETH**

Change tooth. See “Replacing crusher teeth” on page 62.

#### **DROP IN HYDRAULIC PRESSURE ON BASE MACHINE**

Adjust pressure. See “Product specifications” on page 74.

#### **OIL LEAKAGE WITHIN CYLINDER**

The attachment must be serviced in an authorized Sandvik service shop.

### 9.2 MACHINE DOES NOT CUT

---

#### **WORN CUTTING BLADES**

Turn over the cutting blades and adjust. If necessary, change the cutting blades. See “Turning and changing cutting blades” on page 53. See “Turning and changing cutting blades” on page 56.

#### **CUTTING BLADE DOES NOT FIT PROPERLY ONTO THE CUTTER BASE**

Refit and tighten with bolts. See “Turning and changing cutting blades” on page 53. See “Turning and changing cutting blades” on page 56.

#### **INCORRECT CLEARANCE BETWEEN THE BLADES AND BASE**

Check the clearance and adjust. See “Turning and changing cutting blades” on page 53. See “Turning and changing cutting blades” on page 56.

#### **DROP IN HYDRAULIC PRESSURE ON BASE MACHINE**

Adjust pressure. See “Product specifications” on page 74.

#### **OIL LEAKAGE WITHIN CYLINDER**

The attachment must be serviced in an authorized Sandvik service shop.

### 9.3 CRUSHER JAW DOES NOT MOVE

---

#### **MALFUNCTION IN EXCAVATOR HYDRAULIC SYSTEM**

Check the operation of auxiliary circuit.

#### **BALL VALVES MAY BE CLOSED**

Open the ball valves.

#### **CRUSHER JAW MAY BE BLOCKED**

Remove obstacles.

**OIL LEAKAGE WITHIN CYLINDER**

The attachment must be serviced in an authorized Sandvik service shop.

**CYLINDER ROD IS BENT**

The attachment must be serviced in an authorized Sandvik service shop.

---

**9.4 EXCESSIVE MOVING**

---

**WORN PINS AND BUSHINGS**

The attachment must be serviced in an authorized Sandvik service shop.

---

**9.5 OIL LEAKAGE**

---

**OIL LEAKAGE AT HOSE END**

Check the hose end and tighten.

**OIL LEAKAGE AT SWIVEL JOINT**

The attachment must be serviced in an authorized Sandvik service shop.

**CYLINDER SEALS ARE DAMAGED**

The attachment must be serviced in an authorized Sandvik service shop.

---

**9.6 HIGH SPEED VALVE PROBLEMS**

---

**OIL LEAKAGE BELOW SPOOL AND BODY**

Check the sealing of the spool.

**OIL LEAKAGE IN THE CARTRIDGES**

Check the sealing of the cartridges.

**CLOSING TIME TOO LONG**

- RSHC-cartridge is not functioning.
- Too much backpressure. Too small oil lines.
- Cartridges are disadjusted.

**MACHINE DOES NOT CUT OR CRUSH**

- CSAD-cartridge is not functioning.
- Cartridges are disadjusted.

**OIL OVERHEATS**

- Too much backpressure. Too small oil lines.
- Cartridges are disadjusted.

## 9.7 FURTHER ASSISTANCE

---

### FURTHER ASSISTANCE

If further assistance is required, please prepare to answer the following questions before calling your dealer.

- Model and serial number
- Working hours and service history
- Carrier model
- Installation: Oil flow, operating pressure and return line pressure if known
- Application
- Has the product operated normally before



---

# SPECIFICATIONS

---

# I. PRODUCT SPECIFICATIONS

## I.1 TECHNICAL SPECIFICATIONS

Item	Specification
Weight, with crusher teeth, D-JAW	2210 kg
Weight, with pulverizer, D-JAW	2350 kg
Weight, with wood cutter, D-JAW	2260 kg
Weight, S-JAW	2270 kg
Weight, M-JAW	2250 kg
Max. jaw opening, D-JAW	702 mm
Max. jaw opening, S-JAW	859 mm
Max. jaw opening, M-JAW	373 mm
Max. cutting force	2800 kN
Crushing force, front, D-JAW	880 kN
Crushing force, front, S-JAW	750 kN
Crushing force, front (F1), M-JAW	700...850 kN
Crushing force, rear, D-JAW	1350 kN
Crushing force, rear, S-JAW	980 kN
Crushing force, middle (F2), M-JAW	1200...1700 kN
Max. operating pressure	320 bar
Oil flow (recom.)	230 l/min
Hose connections	SAE 6000 psi 1 1/4
Max. operating pressure, rotation	120 bar
Max. oil flow, rotation	30 l/min
Connections, rotation	SAE JIC 06 (9/16-18)
Cutting blade length, D-JAW	130 mm
Cutting blade length, S-JAW	400 mm
Cutting blade length, M-JAW	425 mm
Optimum oil temperature	40...60 °C
Allowed oil temperature range	-20...80 °C
Optimum oil viscosity at operating temperature	30...60 cSt
Allowed oil viscosity range	20...1000 cSt
Carrier weight <sup>a</sup>	16...25 t

a. Check carrier's lifting capacity from carrier manufacturer

## I.2 MAIN DIMENSIONS D-JAW

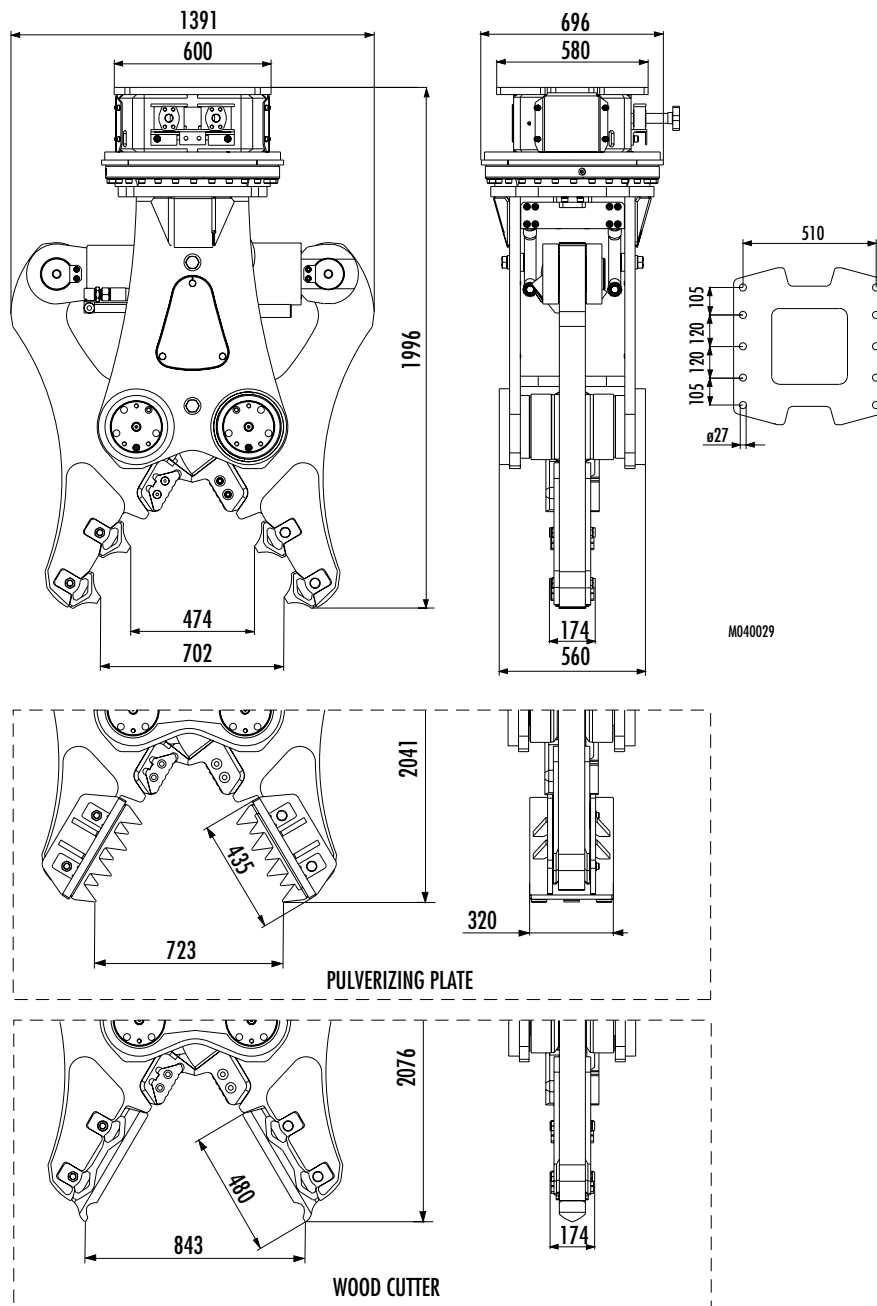

### I.3 MAIN DIMENSIONS S-JAW

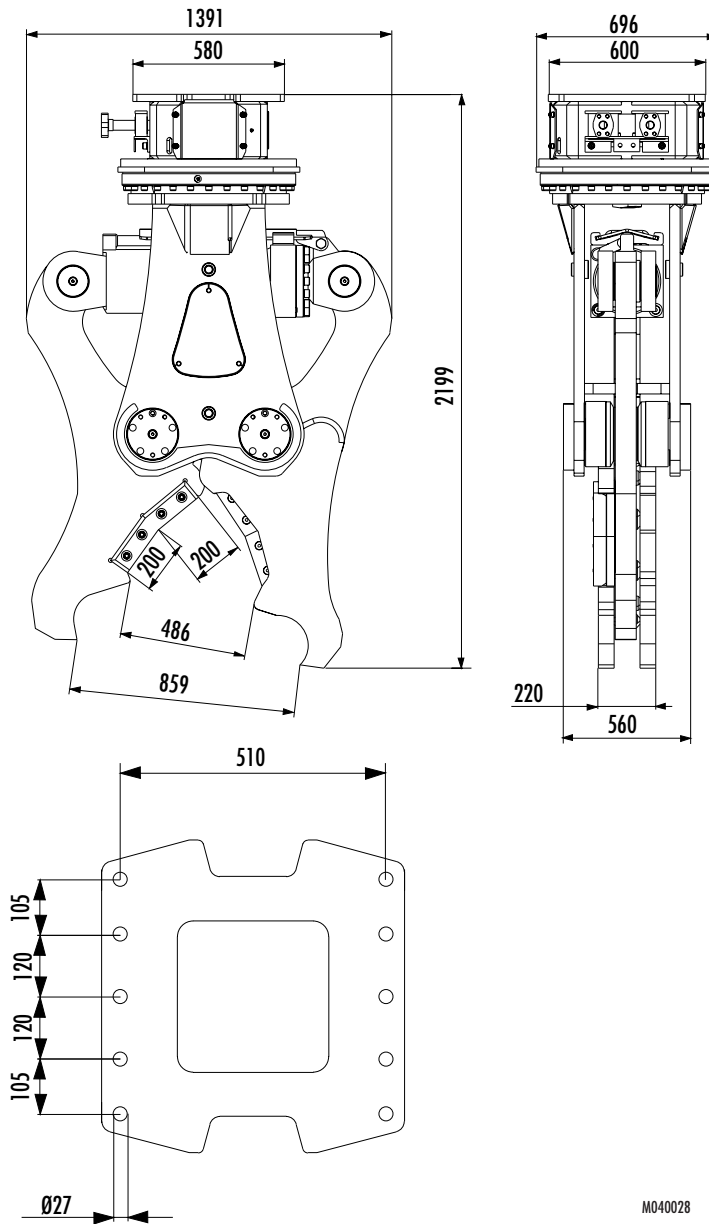

M040028

### I.4 MAIN DIMENSIONS M-JAW

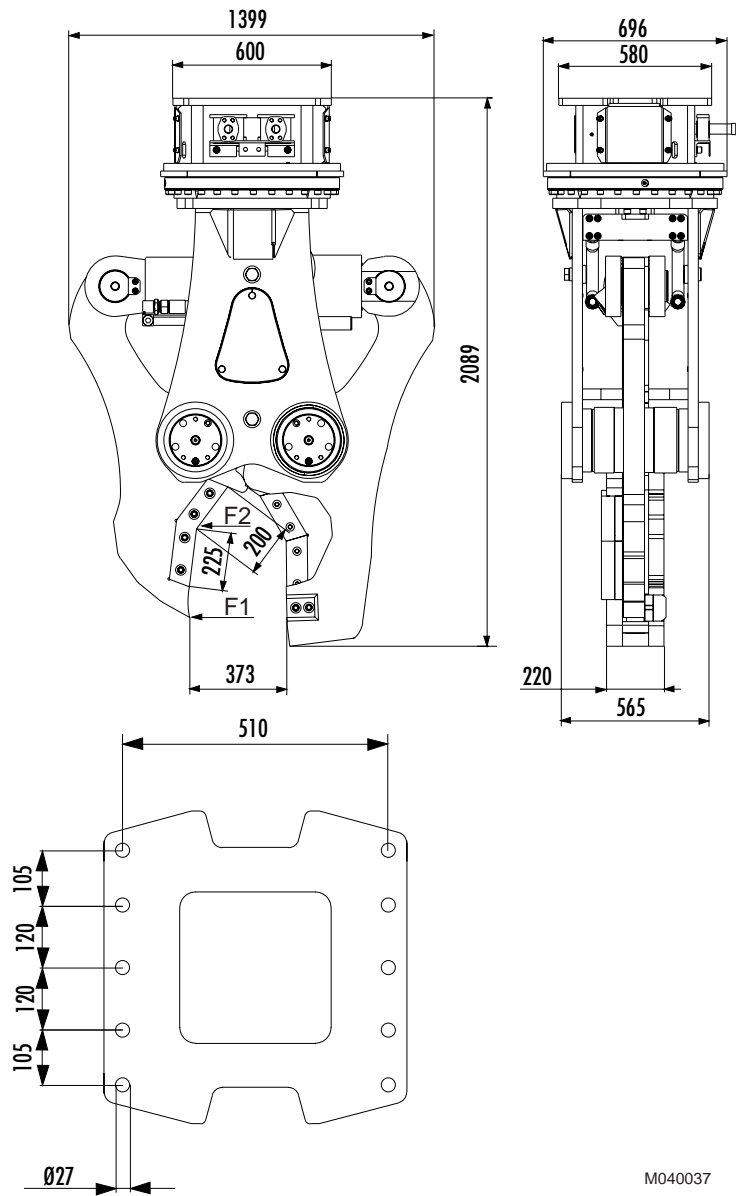

M040037





42-24-14049-42-60-224  
42-24-14049-42-100-217

SANDVIK MINING AND CONSTRUCTION OY, BREAKERS LAHTI P.O. BOX 165, (TAIVALKATU 8), FI-15101 LAHTI, FINLAND

TEL. +358 205 44 151 FAX +358 205 44 150 [www.sandvik.com](http://www.sandvik.com)